



**EUIPO**  
EUROPEAN UNION  
INTELLECTUAL PROPERTY OFFICE

International Cooperation and Legal Affairs Department  
Legal Practice Service

---

# OVERVIEW OF GC/CJ CASE-LAW 2018

STATUS: 31/12/18



The Legal Practice Service of the International Cooperation and Legal Affairs Department prepares a yearly overview of the GC/CJ case-law regarding trade mark and design matters. The judgments and orders are arranged in categories to be browsed more easily according to their content.

This overview includes judgments, preliminary rulings and important orders rendered by the GC and the CJ.

Cases in which the GC or CJ have decided differently from the EUIPO are indicated by the symbol ♦ before the case number.

Cases which are cited in more than one category in the present report are indicated by the symbol ◆ before the case number.

The European Union trade mark Legislative Reform package comprised a complex set of legal texts with changing references and numbering of Articles. For reasons of simplification, the numbering of Articles in this overview refers to:

- EUTMR: Regulation (EU) 2017/1001 of the European Parliament and of the Council of 14 June 2017 on the European Union trade mark (codification);
- EUTMDR: Commission Delegated Regulation (EU) 2018/625 of 5 March 2018 supplementing Regulation (EU) 2017/1001 of the European Parliament and of the Council on the European Union trade mark, and repealing Delegated Regulation (EU) 2017/1430;
- EUTMIR: Commission Implementing Regulation (EU) 2018/626 of 5 March 2018 laying down detailed rules for implementing certain provisions of Regulation (EU) 2017/1001 of the European Parliament and of the Council on the European Union trade mark, and repealing Implementing Regulation (EU) 2017/1431;

except for those cases in which there is no equivalent provision in the current EUTMR, EUTMDR or EUTMIR or the content of the provision is different and this has an implication in the judgment or order. In those cases the specific legal text is mentioned.

References to the EUTMR in the chapter headings should be read as extending to the equivalent rules in Directive 2008/95/EC of the European Parliament and of the Council of 22 October 2008 to approximate the laws of the Member States relating to trade marks (Codified version), where such equivalent exists.

For internal users (EUIPO staff) the judgment, ruling or order and its available translations can be accessed by CTRL + click on the respective case number. For external users, or more detailed information, please see the GC/CJ Database which can be accessed online at <http://curia.europa.eu/>, which contains keywords, relevant legal norms, facts in brief and headnotes of each judgment, including the official translations, or see the eSearch Case Law database which can be accessed online at <https://euiipo.europa.eu/eSearchCLW/>.

Please note that the document does not necessarily reproduce the exact wording of the judgments, preliminary rulings or orders.



CTRL + click on the titles of the index to go directly to the text (internal EUIPO users only).



## Table of Contents

<b>I.</b>	<b>PROCEDURAL MATTERS .....</b>	<b>5</b>
A.	Procedure before the GC/CJ .....	5
1.	Admissibility .....	5
2.	Essential procedural requirements .....	15
3.	General principles of European Union Law.....	19
B.	Procedure before Boards of Appeal.....	19
1.	Admissibility .....	19
2.	Essential procedural requirements .....	25
3.	General principles of European Union Law.....	47
<b>II.</b>	<b>ABSOLUTE GROUNDS FOR REFUSAL/INVALIDITY .....</b>	<b>50</b>
A.	Article 7(1)(a), 59(1)(a) EUTMR — Signs which do not conform the requirements of Article 4 EUTMR .....	50
B.	Article 7(1)(b), (c) and (d), 59(1)(a) EUTMR — Non-distinctive and descriptive trade marks, customary signs and indications.....	51
1.	Outcome: Non-distinctive (Article 7(1)(b) EUTMR) .....	51
2.	Outcome: Distinctive (Article 7(1)(b) EUTMR) .....	69
3.	Outcome: Descriptive (Article 7(1)(c) EUTMR) .....	75
4.	Outcome: Not descriptive (Article 7(1)(c) EUTMR) .....	103
5.	Customary signs and indications (Article 7(1)(d) EUTMR).....	112
C.	Article 7(1)(e), 59(1)(a) EUTMR — Shapes or other characteristics with an essentially technical function, substantial value or resulting from the nature of the goods.....	113
D.	Article 7(1)(f), 59(1)(a) EUTMR — Trade marks contrary to public policy or accepted principles or morality .....	117
E.	Article 7(1)(g), 59(1)(a) EUTMR — Deceptive trade marks.....	119
F.	Article 7(1)(h) and (i), 59(1)(a) EUTMR — Trade marks in conflict with flags and other symbols.....	122
G.	Article 7(1)(j), (k), (l) and (m), 59(1)(a) EUTMR — Trade marks in conflict with geographical indications, traditional terms for wines, traditional specialities guaranteed and earlier plant variety denominations .....	122
H.	Article 7(3), 59(2) EUTMR — Acquired distinctiveness through use .....	125
<b>III.</b>	<b>RELATIVE GROUNDS FOR REFUSAL/INVALIDITY .....</b>	<b>131</b>
A.	Article 8(1)(a), 60(1)(a) EUTMR — Double identity.....	131
B.	Article 8(1)(b), 60(1)(a) EUTMR — likelihood of confusion .....	132
1.	Outcome: Likelihood of confusion (LOC) .....	132
2.	Outcome: No likelihood of confusion (NO LOC).....	195
3.	Other LOC related cases.....	237
C.	Article 8(3), Article 60(1)(b) EUTMR — Unauthorised filing by agents of the TM proprietor.....	245



D.	Article 8(4), Article 60(1)(c) EUTMR — Non-registered marks/other signs used in the course of trade .....	247
E.	Article 8(2)(c), 8(5), 60(1)(a) EUTMR — Well-known marks / trade marks with a reputation .....	258
F.	Other issues .....	274
<b>IV.</b>	<b>PROOF OF USE .....</b>	<b>277</b>
<b>V.</b>	<b>OTHER CANCELLATION GROUNDS .....</b>	<b>291</b>
A.	Article 58(1)(a) EUTMR — Revocation due to non-use .....	291
B.	Article 59(1)(b) EUTMR — Bad Faith .....	300
C.	Article 60(2) EUTMR — Other earlier rights.....	306
D.	Article 61 EUTMR — Acquiescence .....	307
<b>VI.</b>	<b>DESIGNS .....</b>	<b>308</b>
A.	Registration proceedings .....	308
B.	Invalidity proceedings and grounds for invalidity .....	309
C.	Other issues .....	325
<b>VII.</b>	<b>ENFORCEMENT .....</b>	<b>328</b>
<b>VIII.</b>	<b>OTHER.....</b>	<b>332</b>
A.	Restriction of the list of goods and services .....	332
B.	EU collective marks .....	333
C.	Res judicata.....	337
D.	Copyright.....	339
E.	Impact of the 23 June 2016 referendum on withdrawal of the United Kingdom from the EU .....	341
<b>Annex 1:</b>	<b>.....</b>	<b>342</b>



## I. PROCEDURAL MATTERS

### A. Procedure before the GC/CJ

#### 1. Admissibility

##### 1.1. Right to appeal, form, deadline

♦[T-387/17](#); **FORM EINES BALLÄHNLICHEN KÖRPERS MIT KANTEN (3D)**; *Triggerball GmbH v EUIPO*; Judgment of 16 May 2018; EU:T:2018:272; Language of the case: DE. The applicant sought to register the three-dimensional mark 'FORM EINES BALLÄHNLICHEN KÖRPERS MIT KANTEN' as an EUTM for various goods in Classes 5 and 10. The Office partly refused the mark, citing Article 7(1)(b) EUTMR. The Board of Appeal (BoA) dismissed the applicant's appeal. It found that the mark was non-distinctive for all the goods as the relevant public, whose level of attention was normal, would see nothing in the mark beyond the usual aspects of a massage ball. The applicant appealed to the General Court (GC), relying on one sole plea in law: infringement of Article 7(1)(b) EUTMR. **Admissibility of documents before the court.** A document meant to further illustrate the appearance of a three-dimensional mark is not admissible before the court (para. 15).

♦[T-657/17](#); **HPC POLO / POLO et al.**; *Gidon Anabi Blanga v EUIPO*; Judgment of 20 June 2018; EU:T:2018:358; Language of the case: EN. The applicant sought to register the word mark **HPC POLO** for goods in, inter alia, Classes 18 and 25. An opposition was filed pursuant to Article 8(1)(b) EUTMR and Article 8(5) EUTMR, based on the EU word mark **POLO** for goods in Classes 18 and 25. The Opposition Division (OD) upheld the opposition for goods in Classes 18 and 25 on the grounds of likelihood of confusion (LOC). The Board of Appeal (BoA) dismissed the applicant's appeal, finding there was LOC for all the identical or similar goods except *whips, harness and saddlery*, for which the earlier mark **POLO** was considered to have weak inherent distinctiveness. The opposition against these goods was, however, upheld on the grounds of Article 8(5) EUTMR. The applicant appealed to the General Court (GC), seeking the annulment of the decision, relying on a single plea in law, infringement of Article 8(1)(b) EUTMR. **Admissibility.** Although the applicant sought annulment of the contested decision in its entirety, their action is inadmissible insofar as the BoA's application of Article 8(5) EUTMR is concerned, since the applicant did not submit a plea in law in support of that specific head of claim (paras 14-16).

##### 1.2. Claims

###### 1.2.1. Claims to issue directions to the EUIPO

[No entry]

###### 1.2.2. Claims for alteration of the EUIPO decision

♦[T-765/16](#); **EL TOFIO EI sabor de CANARIAS (fig.)**; *Grupo Ganaderos de Fuerteventura, S.L. v EUIPO*; Judgment of 25 January 2018; EU:T:2018:31; Language of the case: ES. The applicant sought to register the figurative mark 'EL TOFIO EI sabor de CANARIAS' for a list of goods in Class 29, inter alia, *milk, cheese and milk products; edible fats*. The Office refused to register the mark as an EUTM in its entirety on the grounds of Article 7(1)(c)



EUTMR. 'TOFIO', a bowl linked to the 'majorera' culture used to collect goat's milk, would immediately inform consumers that these 'milk products' originated from goats from the Canary Islands. The sign was also refused on the grounds that it infringed Article 7(1)(j) and (k) EUTMR. The applicant appealed the Office's decision and requested a limitation of the relevant goods to *cheese*. The Board of Appeal (BoA) dismissed the applicant's appeal because it found that the mark was descriptive — it is considered a well-known fact that Fuerteventura has a native race of goats (*cabra majorera*) used to elaborate Queso Majorero (PDO). 'Tofio' appears in the database of the Academia Canaria de la Lengua, as well as on social networks and in the Gran Enciclopedia Virtual Islas Canarias (GEVIC) database in the sense indicated in the Office's decision. Therefore, the sign would be seen as descriptive of the kind of cheese protected. Registration in Spain is not binding and there is no need to evaluate as to Article 7(1)(j) EUTMR because refusal under one ground is sufficient. **The claim for modification of the contested decision.** The admissibility of the appellant's claims as to the modification of a contested decision must be evaluated in the light of the competences attributed to the BoA, and this organism is not competent to declare the registration of an EUTM application. Consequently this claim is inadmissible (paras 24-28).

#### 1.2.3. *Claim by applicant to confirm decision*

[No entry]

#### 1.2.4. *Claim in excess of what is appealable*

♦[T-2/17](#); **MASSI / MASI et al.**; *SRL v EUIPO*; Judgment of 3 May 2018; EU:T:2018:243; Language of the case: EN. The predecessor in title of the EUTM proprietor was granted registration of the word mark **MASSI** as an EUTM for, inter alia, goods in Class 12. An application for invalidity was filed for those goods pursuant to, inter alia, Article 60(1)(a) EUTMR in conjunction with Article 8(1)(b) EUTMR. The Cancellation Division (CD) dismissed the application for invalidity because it related to the same goods, was partly identical as regards the cause of action and subject matter, and concerned parties connected to those involved in application No 5 069 C for a declaration of invalidity. This earlier proceeding was filed by Haro Bicycle Corp. ('Haro'), and had been rejected by the Office in a decision having the force of *res judicata*. The Board of Appeal (BoA) upheld the invalidity applicant's appeal and declared the EUTM to be invalid for all the contested goods. It found that the conditions laid down in Article 63(3) EUTMR were not satisfied, as the invalidity applicant was not the same entity as in earlier proceedings No 5 069 C; that the earlier mark was still well known for *bicycles and parts thereof* in Italy; and that there was a likelihood of confusion (LOC) between the earlier well-known mark **MASI** and the registered EUTM, **MASSI**. The EUTM proprietor filed an action before the General Court (GC), relying on two pleas in law: (i) infringement of Article 63(3) EUTMR and (ii) infringement of Article 60(1)(a) EUTMR in conjunction with Article 8(2)(c) EUTMR. **Other invalidity grounds relied on by the invalidity applicant.** Considering that the BoA did not rule on the other grounds for invalidity and that the Court does not have sufficient material to rule on them either, the invalidity applicant's request that the Court examine them must be rejected as inadmissible (paras 80-83).



#### 1.2.5. Clarification of claim by applicant

[No entry]

#### 1.2.6. Interpretation of claim by Court

♦[T-424/17](#); **FRUIT**; *Fruit of the Loom, Inc. v EUIPO*; Judgment of 22 November 2018; EU:T:2018:824; Language of the case: EN. The EUTM proprietor registered the word mark **FRUIT** as an EUTM for *clothing, footwear, headgear* in Class 25. A revocation application was filed pursuant to Article 58 EUTMR. The Cancellation Division (CD) upheld the revocation application. The EUTM proprietor filed an appeal. The Board of Appeal (BoA) dismissed the appeal. It found that genuine use of the mark had not been proven. The proprietor filed an action with the General Court (GC). The GC upheld the action. It found that the BoA's assessment of the evidence and the circumstances of the case did not satisfy the criteria laid down by case-law and referred the case back to the BoA. The BoA dismissed the proprietor's appeal. It found that insofar as the contested mark had not been genuinely used for *footwear and headgear*, it had to be declared revoked for those goods. As regards *clothing*, the evidence produced could not be regarded as containing any indication of use of the contested mark. Furthermore, even if it were considered that the goods presented in the various catalogues relied on by the proprietor bore the contested mark, the commercial acts relied on by the proprietor were not sufficient to classify the use claimed as genuine. The proprietor merely asserted that it had participated in a single fashion trade fair, held in Berlin in July 2012, and sent out catalogues. Those commercial acts, seen in the light of the proprietor's decision to stop the launch of the 'Born in the USA' clothing range, a decision that was not the result of an unsuccessful attempt to market its goods, were insufficient to show that the contested mark had been genuinely used. The proprietor appealed to the GC, relying on two pleas in law: (i) infringement of Article 18(1) EUTMR and (ii) infringement of Article 72(6) EUTMR. **Compliance with the judgment of the Court.** It is apparent from the contested decision that the BoA complied with the judgment of 07/07/2016, T-431/15, **FRUIT**, EU:T:2016:395, insofar as it essentially found, following its assessment of the evidence submitted by the proprietor, that, even if some of the promotional commercial acts relied on by the proprietor were established, they were not sufficient, on account of their number, their volume and the fact that they were concentrated over a very short period of time, to classify the use of the contested mark claimed by the proprietor as genuine use. It was only at the ultimate stage of its reasoning that the BoA took account of the proprietor's commercial decision to interrupt the launch of the 'Born in the USA' clothing range (para. 124). In addition, the BoA found that there was no genuine use of the contested mark 'also for that reason', namely 'also' on account of the stopping of the launch of the 'Born in the USA' clothing range. Therefore, it cannot be considered at all that the BoA based its decision on that circumstance alone (para. 125). Consequently, it must be held that the BoA did not disregard the authority of *res judicata* attached to the judgment of 07/07/2016, T-431/15, **FRUIT**, EU:T:2016:395. It is thus necessary to also reject this plea regarding compliance with the judgment of the Court and, therefore, to dismiss the action in its entirety (para. 126).

#### 1.2.7. Claim that the case has become devoid of purpose

[No entry]



### 1.3. *Undisputed facts, arguments, grounds or evidence*

♦[C-84/17 P](#), [C-85/17 P](#) and [C-95/17 P](#) (joined cases); **SHAPE OF A FOUR FINGER CHOCOLATE BAR (3D mark)**; *Mondelez UK Holdings & Services Ltd v EUIPO — Société des produits Nestlé SA*; Judgment of 25 July 2018; EU:C:2018:596; Language of the case: EN. The EUTM proprietor was granted registration of the three-dimensional mark ‘SHAPE OF A FOUR FINGER CHOCOLATE BAR’ as an EUTM for goods in Class 30. An application for invalidity was filed pursuant to Article 59 EUTMR in conjunction with Article 7(1)(b) EUTMR. The Cancellation Division (CD) upheld the application insofar as the mark was devoid of any distinctive character. The Board of Appeal (BoA) upheld the EUTM proprietor’s appeal. It found that although the mark was devoid of any inherent distinctive character, it had acquired this character through use. The invalidity applicant appealed to the General Court (GC). The GC annulled the BoA’s decision in its entirety, as it found that the BoA did not correctly assess the mark’s distinctive character acquired through use, since it had not adjudicated on the relevant public’s perception of the mark in, inter alia, Belgium, Greece, Ireland and Portugal, and had failed to analyse the evidence submitted by the EUTM proprietor with regard to those Member States. The invalidity applicant appealed to the Court of Justice (CJ). **Admissibility of the invalidity applicant’s appeal.** Since the invalidity applicant does not request that the operative part of the judgment be set aside, but only certain grounds of that judgment, the appeal is inadmissible (paras 43, 50). The force of res judicata extends only to the grounds supporting the operative part of a judgment (para. 52). Consequently, when a decision of the EUIPO is annulled by the GC, the grounds upon which the court dismissed certain arguments relied upon by the parties cannot be considered to have gained the force of res judicata (para. 53).

♦[T-724/17](#); **VIANEL/VIANIA et al.**; *The Vianel Group LLC v EUIPO*; Judgment of 22 November 2018; EU:T:2018:825; Language of the case: EN. An opposition based, inter alia, on the EUTM registration for the word mark **VIANIA** was brought against the international registration (IR) designating the EU for the word mark **VIANEL**, pursuant to Article 8(1)(b) EUTMR. The Opposition Division (OD) partially upheld the opposition, namely, for *clothing, namely, sweaters, t-shirts, shirts, blouses, corsets, suits, vests, raincoats, skirts, coats, trousers, pullovers, dresses, jackets, shawls, sashes for wear, scarves, neckties, pocket squares, suspenders, gloves, belts, stockings, tights, socks, singlets, bathing suits and bath robes* in Class 25. It found that genuine use of the earlier mark was proved only for *underwear* in Class 25, and that there was a likelihood of confusion with the contested IR for the abovementioned goods in Class 25. The Board of Appeal (BoA) dismissed the appeal filed by the IR holder. It noted that the IR holder had accepted the OD’s findings on genuine use of the earlier mark and the identity and similarity of the goods. The BoA thus endorsed the OD’s reasoning both in this respect and regarding the likelihood of confusion. The IR holder brought an action before the General Court (GC), relying on two pleas in law: (i) irrelevance of the evidence of genuine use submitted by the opponent before the OD and (ii) infringement of Article 8(1)(b) EUTMR. Since the question of proof of genuine use of the earlier mark was not submitted to the BoA and therefore they did not rule on that matter, the plea to this effect must be declared inadmissible (paras 19-22). Furthermore, since the applicant expressly stated before the BoA that it did not dispute the OD’s findings on the comparison of the goods, the claim relating to the dissimilarity of the goods must also be rejected as inadmissible (paras 25-26).





#### 1.4. *New facts, arguments, grounds or evidence*

♦ [T-765/16](#); **EL TOFIO EI sabor de CANARIAS (fig.)**; *Grupo Ganaderos de Fuerteventura, S.L. v EUIPO*; Judgment of 25 January 2018; EU:T:2018:31; Language of the case: ES. The applicant sought to register the figurative mark ‘EL TOFIO EI sabor de CANARIAS’ for a list of goods in Class 29, inter alia, *milk, cheese and milk products; edible fats*. The Office refused to register the mark as an EUTM in its entirety on the grounds of Article 7(1)(c) EUTMR. ‘TOFIO’, a bowl linked to the ‘majorera’ culture used to collect goat’s milk, would immediately inform consumers that these ‘milk products’ originated from goats from the Canary Islands. The sign was also refused on the grounds that it infringed Article 7(1)(j) and (k) EUTMR. The applicant appealed the Office’s decision and requested a limitation of the relevant goods to *cheese*. The Board of Appeal (BoA) dismissed the applicant’s appeal because it found that the mark was descriptive — it is considered a well-known fact that Fuerteventura has a native race of goats (*cabra majorera*) used to elaborate Queso Majorero (PDO). ‘Tofio’ appears in the database of the Academia Canaria de la Lengua, as well as on social networks and in the Gran Enciclopedia Virtual Islas Canarias (GEVIC) database in the sense indicated in the Office’s decision. Therefore, the sign would be seen as descriptive of the kind of cheese protected. Registration in Spain is not binding and there is no need to evaluate as to Article 7(1)(j) EUTMR because refusal under one ground is sufficient. **The request for limitation.** The applicant’s request to limit the relevant goods to *goat cheese originating from the Canary Islands* must not be taken into consideration because this would modify the subject matter of the case as evaluated before the BoA (paras 11-23).

♦ [T-261/17](#); **SALOSPIR 500 mg (fig.) / Aspirin et al.**; *Bayer AG v EUIPO*; Judgment of 24 October 2018; EU:T:2018:710; Language of the case: EN. The applicant sought to register the figurative mark ‘SALOSPIR’ as an EUTM for goods in Class 5 (*pharmaceuticals*). An opposition was filed pursuant to Article 8(1)(b) EUTMR, Article 8(4) EUTMR (§4(2) German law) and Article 8(5) EUTMR. It was based on the earlier German figurative mark ‘Aspirin’, the earlier German word mark ‘Aspirin’, the earlier EU figurative trade marks and the non-registered sign ‘ASPIRIN’ (packaging) in Germany. The Opposition Division (OD) dismissed the opposition, so the opponent appealed. The Board of Appeal (BoA) dismissed the appeal. It held that the contested mark was different from the earlier German marks and from the earlier EU figurative marks, and that the opponent had not proved that German law granted protection to the non-registered sign. The opponent filed an action before the General Court (GC), relying on three pleas in law: (i) infringement of Article 8(1)(b) EUTMR, (ii) infringement of Article 8(5) EUTMR, and (iii) infringement of Article 8(4) EUTMR. **Inadmissibility of the new evidence before the GC.** The new evidence submitted before the GC intended ‘to prove a matter of common knowledge’ (a presentation referring to methodology in surveys). However, as the accuracy of the methodology governing the consumer recognition surveys is contested, this cannot be considered ‘a matter of common knowledge’ and is, therefore, inadmissible (para. 19). New evidence which seeks to contest an assessment made by the BoA is also inadmissible (para. 20).

♦ [T-120/17](#); **FLUO. (fig.)**; *M & T Emporia Ilektrikon-Ilektronikon Eidon AE v EUIPO*; Judgment of 11 October 2018; EU:T:2018:672; Language of the case: EN. The applicant sought to register the figurative mark ‘FLUO.’ as an EUTM for goods in, inter alia, Class 9. The Office refused to register the EUTM application pursuant to Article 7(1)(b) and (c) EUTMR, as it was descriptive and devoid of distinctive character. The applicant filed an appeal. The Board of Appeal (BoA) partially dismissed the appeal and the applicant filed an action with the General Court (GC), relying on two pleas in law: (i) infringement of



Article 7(1)(c) EUTMR and (ii) infringement of Article 7(1)(b) EUTMR. **New submission of evidence before the GC.** New evidence consisting of a market study on the perception of the word ‘fluo’ by the French-speaking public is inadmissible, since as it was not produced by the applicant during the proceedings before the EUIPO (paras 15, 17).

### **1.5. Limitation, including restriction of goods and services**

[No entry]

### **1.6. Matters of fact appealed to CJ**

♦[C-412/16 P](#) and [C-413/16 P](#) (joined cases); **ocean beach club Ibiza (fig.) et al. / OC ocean club Ibiza (fig.) et al.**; *Ice Mountain Ibiza, S.L. v EUIPO*; Judgment of 1 March 2018; EU:C:2018:140; Language of the case: ES. The applicant sought to register the figurative marks ‘ocean beach club Ibiza’ as EUTMs for, inter alia, services in Class 41. Two oppositions based on the earlier Spanish figurative marks ‘OC ocean club Ibiza’ registered for services in Class 41 were filed respectively pursuant to Article 8(1)(b) EUTMR. The Opposition Division (OD) upheld both oppositions and the applicant appealed them. The Board of Appeal (BoA) dismissed both appeals as it found likelihood of confusion. The applicant filed two actions before the General Court (GC) relying on a single plea in law, infringement of Article 8(1)(b) EUTMR, which was dismissed, insofar as the GC found likelihood of confusion given the identity or similarity of the services and the similarity of the signs. The applicant filed two actions before the Court of Justice of the European Union (CJ) relying on four pleas in law: (i) the incorrect assessment of the distinctiveness of the element ‘OCEAN’, (ii) the incorrect assessment of the dominant character of the various elements, (iii) the GC ignored relevant jurisprudence in its assessment of the similarity of the signs, and (iv) the GC erred in concluding that there was a likelihood of confusion. (i) The GC did not distort the evidence when it determined that the association with the sea was not a necessary characteristic of the services (paras 39-40). The GC did not err in not applying the judgment in case C-479/12, which interpreted Regulation No 6/2002 on Community Designs (para. 42). The GC correctly applied the jurisprudence of the burden of proof, without infringing the right of defence. The GC duly took into account the perception of the public when assessing the distinctive character of the word ‘ocean’ and it did not demand an excessive or too rigorous level of evidence (paras 44, 49 and 50). (ii) The GC did not apply automatically the principle that verbal elements are in general more important than figurative elements, but, after examining the position and the dimensions of the word element in the mark, concluded that the word elements were at least as dominant as the figurative elements (paras 63 to 69). The CJ clarifies the content of judgment in case T-134/06, namely that although the position and the dimensions of a weak element should be taken into account when assessing the dominant character of that element, these are not the only ones to be considered (paras 80-81). The CJ confirms that the alleged case-law concerning invalidity proceedings under Regulation No 6/2002 is not applicable to the present case because the criteria are different (para. 83); (iii) Since the arguments only question the GC’s assessment of facts concerning the similarity of the signs, in the absence of claiming a distortion of facts, this plea in law is inadmissible (paras 90-97); (iv) The GC duly considered the argument on coexistence. It identified the criteria correctly and pointed out that the applicant had the possibility of submitting evidence in order to prove that peaceful coexistence was due to the lack of likelihood of confusion, and that evidence showing that the relevant public was already aware of each of the marks before the application for registration of the contested mark was particularly relevant to that effect



(paras 103-105).

**C-139/17 P**; **medialbo / MediaLB et al.**; *QuaMa Quality Management GmbH v EUIPO*; Judgment of 25 July 2018; EU:C:2018:608; Language of the case: DE. The appellant sought to register the word mark **medialbo** as an EUTM for goods and services in Classes 9, 35, 37, 41 and 42. An opposition based on the earlier EUTM **MediaLB**, registered for goods and services in Classes 9, 41 and 42 was filed pursuant to Article 8(1)(b) EUTMR on the last day of the time limit set to file an opposition. The opposition was accompanied by an application to change the name and address of the proprietor of the earlier mark. The Opposition Division (OD) informed the opponent that it appeared that the opponent was seeking a transfer of the mark and not a change of name and address. The opponent then filed an application for the registration of a transfer of the earlier mark and the OD registered that transfer and subsequently rejected the initial request for a change of name and address. OD partly upheld the opposition. The appellant and the opponent appealed and the Board of Appeal (BoA) dismissed both appeals. It found, in particular, as regards the alleged infringement of Article 5(5) EUTMDR, that it was sufficient to apply for the registration of a transfer on the same day of the opposition, and that the fact that the opponent had filed an application for a change of name and address, and not a transfer, would only have been a legally incorrect presentation of one and the same situation, which was soon after rectified. Therefore, the identity of the opponent and owner of the earlier mark was always clear. The appellant appealed to the General Court (GC) relying on two pleas in law: (i) infringement of Article 46(1) EUTMR and, (ii) infringement of Article 8(1)(b) EUTMR. The GC dismissed the appeal. The appellant appealed to the Court of Justice of the European Union (CJ), raising the same two pleas in law as before the GC. **Distortion of facts and evidence.** The allegation by the appellant that the GC distorted the facts and evidence when it accepted that the belated request for a transfer had already been made with the opposition must be rejected as inadmissible as the appellant does not succeed in establishing any distortion of those elements. The appellant confines itself to explaining how the GC should have assessed those elements without, however, setting out precisely the errors of assessment which it considers led to that distortion. The appellant thus presents its own assessment of the facts and evidence already submitted to the GC without showing that the GC clearly exceeded the limits of a reasonable assessment of those facts and evidence (para. 37). The appellant's allegations that there was insufficient evidence of a transfer of the earlier mark to the new proprietor within the opposition period are also inadmissible, as such allegations were not contained in the application lodged with the GC. That is to be regarded as a new plea in law, which amends the subject matter of the proceedings before the GC (para. 45). **Identification of relevant public for each category of goods and service.** Insofar as the appellant refers to the GC's conclusion as to the definition of the relevant public based on the findings of the OD, it is settled case-law that the findings on the characteristics of the relevant public and its attention or attitude fall within the scope of factual assessment, which, unless distorted, is not a matter of law under the jurisdiction of the CJ (para. 55).

♦**C-488/16 P**; **NEUSCHWANSTEIN**; *Bundesverband Souvenir — Geschenke — Ehrenpreise v EUIPO*; Judgment of 6 September 2018; EU:T:2018:673; Language of the case: DE. The EUTM proprietor registered the word mark **NEUSCHWANSTEIN** as an EUTM for goods and services in Classes 3, 8, 14 to 16, 18, 21, 25, 28, 30, 32 to 36, 38 and 44. An application for invalidity was filed pursuant to Article 59(1)(a) EUTMR in conjunction with Article 7(1)(b) and (c) EUTMR. The Cancellation Division (CD) dismissed the application for invalidity. This was because firstly, the contested mark did not consist of indications which might serve to indicate the geographical origin or other characteristics of the goods and services concerned. Secondly, it was distinctive for those goods and



services, and thirdly, the invalidity applicant did not prove that the EUTM proprietor had acted in bad faith. The Board of Appeal (BoA) confirmed the CD's decision and dismissed the appeal. The invalidity applicant appealed to the General Court (GC), relying on three pleas in law: (i) infringement of Article 7(1)(b) EUTMR (ii) infringement of Article 7(1)(c) EUTMR, (iii) infringement of Article 59(1)(b) EUTMR. The GC rejected the three pleas of the invalidity applicant and dismissed the action in its entirety. The invalidity applicant appealed to the Court of Justice of the European Union (CJ). **Bad faith.** Pleading bad faith on the EUTM proprietor's part without identifying even the slightest distortion of the evidence upon which the GC based its assessment of that issue is inadmissible. This only means that the invalidity applicant is in fact attempting to call into question the assessment of the evidence carried out by the GC, which cannot be done before the CJ (paras 79-81).

### 1.7. *Other, including general reference to previous statements*

♦[T-103/17](#); **NORMOSANG / NORMON et al.**; Recordati Orphan Drugs v EUIPO; Judgment of 9 March 2018; EU:T:2018:126; Language of the case: EN. The EUTM applicant sought to register the word mark **NORMOSANG** for the goods in Class 5 (Pharmaceutical preparations containing human hemin). An opposition based on four earlier rights was filed pursuant to Article 8(1)(b) and Article 8(5) EUTMR. The applicant asked that the scope of the EU mark be limited to the following goods in Class 5: *Pharmaceutical preparations containing human hemin for administration by injection or perorally for the treatment of hepatic porphyria*. The intervener submitted a statement setting out its grounds for opposition and the applicant contended that it had only proved the existence of the international registration and requested that it submit proof that its earlier rights had been genuinely used. The Opposition Division (OD) upheld the opposition for all the goods concerned on the ground that there was a likelihood of confusion (LOC) with the Spanish word mark **NORMON**. The applicant appealed OD's decision, and the Board of Appeal (BoA) dismissed the applicant's appeal. The BoA held that the existence and validity of the earlier Spanish mark had been duly proved. It also found that the relevant public were health professionals and patients with a high level of attention; that the goods were identical; that the marks at issue were visually and phonetically similar; and that there was LOC. The EUTM applicant filed an action before the General Court (GC) relying on two pleas in law: (i) infringement of Article 7(2)(a)(ii) EUTMDR and Article 8(1) and (7) EUTMDR and (ii) infringement of Article 8(1)(b) EUTMR. **Admissibility.** The Court declared that the general reference made by the applicant to the arguments submitted before the Office are inadmissible (para. 25). The Court also considered that annexes A8 and A9 containing evidence submitted for the first time before the Court are also **inadmissible** (paras 28-30).

♦[T-241/16](#); **EW (fig.) / WE**; *El Corté Inglés, SA v EUIPO*; Judgment of 4 May 2018; EU:T:2018:55; Language of the case: EN. The applicant sought to register the figurative mark 'EW' for goods in Classes 3, 18 and 25. An opposition based on the EU word mark **WE** for goods in Classes 3, 18 and 25 was filed pursuant to Article 8(1)(b) and Article 8(5) EUTMR. The Opposition Division (OD) upheld the opposition for all contested goods except for *walking sticks* in Class 18 and the Board of Appeal (BoA) dismissed the applicant's appeal. It found that there was likelihood of confusion (LOC) for all the goods that had been found to be identical, similar or similar to a low degree because the signs were visually and phonetically similar to an average degree. The applicant appealed an annulment before the General Court (GC) relying on a single plea in law, alleging infringement of Article 8(1)(b) EUTMR. **Admissibility of a general reference to the written pleadings submitted before the Office.** An application before the GC must contain a brief statement of the pleas



in law on which it is based. It follows that a general reference to other documents cannot compensate for the failure to set out the essential elements of the legal argument, which must appear in the application itself, and is inadmissible (paras 14-16).

♦[T-234/17](#); **DIAMOND ICE / DIAMOND CUT**; *Siberian Vodka AG v EUIPO*; Order of 3 May 2018; EU:T:2018:259; Language of the case: DE. The international registration holder (IR holder) sought to register the international registration designating the EU, **DIAMOND ICE**, for goods in Class 33. An opposition based on the earlier EU word mark **DIAMOND CUT**, registered for goods in Class 33, was filed pursuant to Article 8(1)(b) EUTMR. The Opposition Division (OD) upheld the opposition insofar as it found likelihood of confusion. The IR holder appealed and the Board of Appeal (BoA) dismissed the appeal, since it also found likelihood of confusion, given the identity between the goods, the average phonetic and visual similarity, as well as the average inherent distinctiveness. The IR holder filed an action before the General Court (GC) relying on a single plea in law: infringement of Article 8(1)(b) EUTMR. **The general reference to previous statements.** No specific reference is made to the elements that the BoA failed to take into account. The generic reference to the documents and evidence adduced during the opposition proceedings is not sufficient and it is not for the Court to find in the file of the proceedings before the Office arguments to which the applicant might be referring or to examine them (paras 45-47).

♦[C-547/17 P](#); **RAPPRESENTAZIONE DI TRE STRISCE VERTICALI (fig.)**; *Basic Net SpA v EUIPO*; Judgment of 6 September 2018; EU:T:2018:682; Language of the case: IT. The applicant sought to register the figurative mark ‘RAPPRESENTAZIONE DI TRE STRISCE VERTICALI’ as an EUTM for goods in Classes 18, 25 and 26. The mark was identified in the application form as a figurative mark that claimed three shades of yellow, orange and blue Pantone colours. The Office refused registration of the EUTM application pursuant to Article 7(1)(b) EUTMR. The Board of Appeal (BoA) dismissed the applicant’s appeal. It found that the mark was devoid of distinctive character and that the applicant had not proved acquisition by that mark of a distinctive character through use. The applicant appealed to the General Court (GC), relying on two pleas in law: (i) infringement of Article 7(1)(b) EUTMR and (ii) infringement of Article 7(3) EUTMR. The GC dismissed the appeal. It found that, first, the mark was devoid of any distinctive character and, second, that the acquisition by the mark of a distinctive character had only been proved for France, Italy, the Netherlands and the United Kingdom. For Belgium, Germany, Spain and Austria, the applicant had provided as evidence of use a sworn declaration mentioning turnover and sales data for goods marketed under the disputed mark, but no other evidence to corroborate it. The applicant appealed to the Court of Justice of the European Union (CJ). In support of its appeal, the opponent relies, primarily, on a single plea, alleging infringement of Article 7(3) EUTMR and the obligation to state reasons. In the alternative, it puts forward three other pleas alleging infringement of Article 7(1)(b) EUTMR, failure to take account of another EUTM belonging to it and failure to take into consideration other registered marks consisting of combinations of colours, respectively. **Obligation to state reasons.** Since the GC stated the grounds on which it held that acquisition by the mark of distinctive character through use had not been proved for a number of EU countries, namely Belgium, Germany, Spain, Hungary and Austria, the opponent is not justified in accusing the GC of a breach of the obligation to state reasons in that regard (para. 39). **Inadmissibility of the alternative pleas in law.** Considering that in support of its three alternative pleas, the opponent fully reproduces, in its appeal, the arguments previously put forward before the GC, without setting out in detail the parts of the contested judgment concerned by those pleas or developing a specific legal argument capable of calling into question the assessments of the GC, those three pleas must be rejected as inadmissible (paras 42-44).



**T-664/16; Erdmann & Rossi; PJ v EUIPO**; Order of 30 May 2018; EU:T:2018:517; Language of the case: DE. The EUTM proprietor, a partner in a law firm, registered, in the name of the company Erdmann & Rossi, the word mark **Erdmann & Rossi** as an EUTM for goods and services in Classes 12, 37 and 42. An invalidity application was filed pursuant to Article 59(1)(b) EUTMR based on bad faith on the behalf of the partner. The Cancellation Division (CD) dismissed the invalidity application. The Board of Appeal (BoA) upheld the appeal and found that the partner had acted in bad faith. In the proceedings before the Office, the partner defended himself. He brought an action before the General Court (GC), signed by Mr S., a lawyer in the law firm in which the EUTM proprietor is a partner. The Office claimed that the proprietor's action was inadmissible because of improper representation. The proprietor transferred the contested mark to [Y]-GmbH and the representative, Mr S., applied for replacement of the proprietor ('the applicant for replacement'). **Admissibility of the plea of inadmissibility.** The Office's plea of inadmissibility is admissible since it was filed, as prescribed, by means of a separate document and within the legal time limit of 2 months of the Office being served the application to the GC plus 10 days on account of distance. In particular, contrary to what the proprietor claims, in the absence in the Rules of Procedure of the General Court (RPoGC) of any indication to the contrary concerning the filing of a document by means of the e-Curia application, it is clear that the additional period of 10 days on account of distance provided for in Article 60 RPoGC applies to the filing of a plea of inadmissibility via the e-Curia application (para. 40). As to the proprietor's claim that it did not appear from the examination of the file carried out by its representative that, when the Office's plea of inadmissibility was lodged on time, the login and password of the Office's agent had been used, it must be regarded that it is technically impossible for one party's representative to personally verify whether and when the other party's representative has used his or her login or password for the e-Curia IT application (para. 41). **Admissibility of the action brought by the proprietor before the GC. Alleged self-representation.** Given that the representative who signed and lodged the action before the GC through the e-Curia application was Mr S., and not the proprietor, the plea of inadmissibility must be dismissed as unfounded insofar as it is based on an alleged self-representation of the party (para. 59). That finding cannot be called into question by the argument that the proprietor gave a power of attorney for litigation to the law firm of which he himself is one of the two founding partners, as the requirement provided for in Article 51(3) RPoGC, that a power of attorney be lodged at the GC Registry, does not apply in cases, such as the present one, where the party is a natural person. Therefore, the fact that the proprietor gave the law firm a power of attorney for litigation has no effect on the assessment of the alleged self-representation (para. 60). There was no self-representation. **Alleged lack of independence of the lawyer representing the proprietor before the GC.** The proprietor is one of the co-founders and one of the two partners of the law firm where the proprietor's representative works as a lawyer without being a partner (para. 62). Since the decisions of that law firm are taken unanimously by its two partners, the proprietor exercises effective control over all the firms' decisions, including decisions relating to its members of staff, and hence to Mr S. Therefore, Mr S. does not enjoy the same degree of independence from his employer as a lawyer working in an external law firm does in relation to his client. Consequently, Mr S. is less able to deal effectively with any conflict between his professional obligations and his client's aims (para. 63). Since the interests of the law firm are largely the same as those of the proprietor, there is a risk that Mr S.'s professional opinion would be, at least partly, influenced by his working environment (para. 64). This professional connection that Mr S. had with the proprietor at the time of the lodging of the action is therefore of such a nature that he may have not been in a position to fulfil his essential role as auxiliary to the GC in the most appropriate way (para. 65). That conclusion cannot be called into question by the



fact that the German national rules on the legal profession provide for the independence of lawyers, given that, according to the case-law, the provisions on representation before the EU Courts must be interpreted, as far as possible, independently and without reference to national law, and the concept of independence of lawyers in EU law is defined not only positively, on the basis of membership of a Bar and adherence to a Code of Conduct and Code of Ethics, but also negatively (para. 67). It follows from settled case-law that fully independent legal assistance is that provided by a lawyer who, structurally, hierarchically and functionally, is a third party in relation to the undertaking receiving that assistance. The fact that the requirement of independence of lawyers representing parties before the GC is not expressly provided by the Statute of the Court of Justice of the European Union (CJEU) cannot undermine the principle of legal certainty (para. 71). **Request for replacement of the appellant (proprietor) by the alleged new proprietor of the contested mark.** There is no need to adjudicate on the request for replacement since the GC has taken the view that the action was inadmissible on the grounds of an irregularity in the representation of the requesting party (para. 78). In any event, the request for replacement could not be regarded as admissible on the facts of this case, where the lawyer who signed the request for replacement, Mr S., is not an independent lawyer in relation to the applicant for replacement (paras 79-80).

♦[T-668/17](#); **Eico / MAICO**; *Maico Holding GmbH v EUIPO*; Judgment of 20 September 2018; EU:T:2018:567; Language of the case: EN. The applicant sought to register the word mark **Eico** as an EUTM for goods in, inter alia, Class 11. An opposition based on the earlier EU word mark **MAICO**, registered for goods in, inter alia, Class 11, was filed pursuant to Article 8(1)(b) EUTMR regarding *apparatus for heating, refrigerating, drying, and ventilating*. The Opposition Division (OD) dismissed the opposition and the opponent filed an appeal. The Board of Appeal (BoA) dismissed the appeal. It found that there was no likelihood of confusion (LOC), insofar as the visual and phonetic differences between the signs outweighed their similarities, given the high level of attention of the relevant public. The opponent filed an action before the General Court (GC), relying on a single plea in law: infringement of Article 8(1)(b) EUTMR. **Request for a hearing.** Although the applicant stated in its application that it requested a hearing, that statement is not equivalent to a request for a hearing within the meaning of the Rules of Procedure of the GC. According to these provisions, it was submitted too early and could not, therefore, be taken into consideration. The GC was therefore entitled to rule on this case without a hearing (para. 13).

## **2. Essential procedural requirements**

### **2.1. Right to be heard**

[No entry]

### **2.2. Duty to state reasons**

♦[C-519/17 P](#) and [C-522/17 P](#) to [C-525/17 P](#) (joined cases); According to Case Quotation Manual: **MASTER PRECISE /MASTERS COLORS PARIS (fig.)**; *L'OréalSA v EUIPO*; Judgment of 30 May 2018; EU:T:2018:348; Language of the case: FR



EUTM application	Earlier trade mark
Master Smoky Master Shape Master Precise Master Duo Master Drama	

The General Court (GC) dismissed the EUTM applicant's action for annulment against the decisions of the Board of Appeal (BoA). Previously, the BoA also dismissed the EUTM applicant's appeal against the decisions of the Opposition Division (OD), finding likelihood of confusion between the word marks applied for and the earlier figurative mark, resulting in the protection of identical goods (Class 3: *eye makeup products*) pursuant to Article 8(1)(b) EUTMR. The EUTM applicant appealed against the GC's orders to the Court of Justice of the European Union (CJ), relying on two pleas in law: (i) distortion of facts and; (ii) infringement of Article 8(1)(b) EUTMR. The CJ found a breach of the duty to provide coherent and complete reasoning (para. 74). This related to the GC's finding that the applicant did not submit any argument challenging the BoA's finding that 'masters' constitutes the most distinctive element of the earlier mark. The reasons provided by the GC were equivocal and incomplete, resulting in the EUTM applicant failing to understand the decision's reasoning. Further, the CJ was unable to exercise judicial review (paras 73-74). The CJ also found a lack of reasoning in the GC's orders as they did not fully answer the applicant's complaint and failed to provide an explanation of its response (paras 81, 82). This regarded the EUTM applicant's argument that the BoA had not examined the conflicting marks as a whole. The decision was annulled and the case was referred back to the GC.

♦ **C-564/16 P; DEVICE OF A JUMPING ANIMAL (FIG. MARK) / PUMA (FIG. MARK) et al.; EUIPO v Puma SE**; Judgment of 28 June 2018; EU:C:2018:509; Language of the case: EN. The applicant sought to register the figurative mark 'DEVICE OF A JUMPING ANIMAL' as an EUTM for goods in Class 7. An opposition was filed based on various earlier international figurative marks for goods in Classes 18, 25 and 28, on the basis of Article 8(5) EUTMR. In support of its claim that the earlier marks were reputed, the opponent had, inter alia, relied upon three previous decisions of the Office in which its reputation had been recognised. The Opposition Division (OD) dismissed the opposition as it found that the relevant public would not establish a link between the marks, without first examining whether the opponent had established the reputation of its earlier marks. The Boards of Appeal (BoA) also dismissed the opponent's appeal finding that it had not established the reputation of its earlier marks. In addition, it also found that, even assuming that the reputation of the earlier marks were to be regarded as proven, the existence of an unfair advantage taken of the distinctive character or repute of the earlier marks or of detriment to their distinctive character or repute, had not been satisfied either. The opponent appealed to the General Court (GC) which annulled the Board's decision for infringement of the principles of legal certainty and sound administration, insofar as the BoA had rejected the evidence relating to the reputation of the earlier trade marks and found that their reputation had not been proved. The Office appealed to the Court of Justice of the European Union (CJ), relying on two pleas in law: (i) infringement of Article 95(1) EUTMR and of the principle of sound administration, read in conjunction with Article 7(2)(c) EUTMDR and Article 8(5) EUTMR, and (ii) infringement of Rule 50(1) CTMIR and of Article 95(2) EUTMR. (i) The opponent is free, in principle, to choose the form of evidence it





considers useful to submit to the Office. Therefore, nothing precludes earlier Office decisions from determining the existence of reputation in other *inter partes* proceedings and being relied on in that context as evidence in support of the reputation of that earlier mark, particularly when they are identified in a precise manner and their substantive content is set out in the notice of opposition in the language of the case (para. 69). The GC did not err when it found that the three previous decisions had been ‘duly relied on’ by the opponent (para. 75). The GC was right to examine whether the BoA, by merely stating in the decision that the Office was not bound by its decision-making practice, had satisfied its obligation to state reasons, due to the context in which the decision had been made and the legal rules governing the matter, including the principles of sound administration and equal treatment (para. 79). Merely stating that the lawfulness of the Office’s decisions must be assessed solely on the basis of EUTMR and not on the basis of its earlier decision-making practice (para. 82) did not satisfy the Office’s bodies obligation to state reasons. The previous decisions, insofar as they had recognised the reputation of the earlier marks, were a strong indication that those marks could also be regarded as having a reputation in the current opposition proceedings (para. 95). The Office was required to take into account the three previous decisions relied on by the opponent, and had to provide an explicit statement of its reasoning insofar as it had decided to depart from the approach adopted in those decisions on the reputation of the earlier marks (para. 96). Therefore, the GC did not err in concluding that it was incumbent on the BoA, in accordance with the principle of sound administration, either to provide the reasons why it disregarded the findings made by the Office in the three previous decisions relating to the reputation of the earlier marks, or request that the opponent submit supplementary evidence of the reputation of the earlier marks (para. 100).

♦[T-623/16](#); **MAIN AUTO WHEELS (fig.) / VW (fig.) et al.**; *Volkswagen AG v EUIPO*; Judgment of 19 September 2018; EU:T:2018:561; Language of the case: DE. The applicant sought to register the figurative mark ‘MAIN AUTO WHEELS’ as an EUTM for goods and services in Classes 12 and 35. An opposition based on, inter alia, the earlier figurative mark ‘VW’, registered for goods and services in Classes 12 and 35, was filed pursuant to Article 8(1)(b) and Article 8(5) EUTMR. The Opposition Division (OD) dismissed the opposition. It found that there was no likelihood of confusion (LOC) as the signs had a very low degree of similarity and produced different overall impressions. Regarding Article 8(5) EUTMR, it held that the opponent had failed to prove unfair advantage. The opponent filed an appeal, which the Board of Appeal dismissed. It found that the signs were dissimilar and that therefore there was no need to compare the goods and services. Since the signs were dissimilar, the opposition also failed insofar as based on Article 8(5) EUTMR. The opponent appealed to the General Court (GC), relying on three pleas in law: (i) infringement of Article 8(1)(b) EUTMR, (ii) infringement of Article 8(5) EUTMR and (iii) infringement of Article 94(1) EUTMR. **Lack of reasoning.** The third plea, an infringement of Article 94 EUTMR, must be dismissed, as the applicant did not in fact allege that the Office had failed to comply with the obligation to state reasons, but simply criticised the soundness of the reasons given (para. 72).

### 2.3. *Ultra petita*

[No entry]

### 2.4. *Other issues*

[T-727/16](#); **REPOWER**; *Repower AG v EUIPO*; Judgment of 21 February 2018;



EU:T:2018:88; Language of the case: FR. The EUTM proprietor was granted registration of the word mark **REPOWER** for goods and services in Classes 4, 9, 37, 39, 40 and 42. An application for invalidity was filed pursuant to Article 59(1)(a) EUTMR in conjunction with Article 7(1)(b) and (c) EUTMR for all the goods and services. The Cancellation Division partly upheld the application for invalidity, as it found that the term 'REPOWER' directly informed English-speaking consumers that the services in Classes 37 and 42 were intended to repair or replace the engine or the energy source of energy installations. The Board of Appeal (BoA) dismissed the invalidity applicant's appeal. The invalidity applicant filed an action before the General Court (GC). Considering that the contested decision was vitiated by a breach of the duty to state reasons, the BoA revoked its decision in order to analyse in further detail the distinctiveness and the descriptiveness of the sign for the contested goods and services. The EUTM proprietor filed a new action before the GC contesting the BoA's revocation decision, relying on four pleas in law: (i) lack of legal basis, (ii) lack of competence of the BoA, (iii) infringement of Article 80(1) of Regulation (EC) No 207/2009, the EUIPO's Guidelines and principles of good administration, legal certainty and res judicata and (iv) failure to state reasons. **On the lack of legal basis.** Article 80(1) of Regulation (EC) No 207/2009, stating that the Office must revoke a decision containing an obvious procedural error, was applicable to the decisions adopted until 1 October 2017 (para. 27). **On the lack of competence of the BoA.** According to Article 103 EUTMR in conjunction with Article 72 EUTMR, the BoA is entitled to revoke its decisions (paras 38 and 41). The fact that an action contesting the decision has been lodged before the GC does not prevent the BoA from revoking it (para. 44). **On the infringement of Article 80 of Regulation (EC) No 207/2009, the EUIPO's Guidelines and several general principles of law.** A procedural error is an error having procedural consequences and not an error related to substantive issues (para. 55). A failure to state reasons has an impact on the substance of the decision and cannot be qualified as a procedural error within the meaning of Article 80(1) of Regulation (EC) No 207/2009 (para. 57). Therefore, the BoA could not revoke its decision on the basis of Article 80(1) of Regulation (EC) No 207/2009 (para. 59). Withdrawal of an unlawful administrative act is a general principle of law recognised by case-law. Since the Boards of Appeal are administrative in nature, they can rely on this general principle to revoke their unlawful decisions (para. 61). Relying on this general principle is possible even where the withdrawal proceedings are already regulated by specific provisions in the law (para. 65). Therefore, the regulation of revocation in Article 80(1) of Regulation (EC) No 207/2009 does not preclude the application of Article 107 EUTMR referring to general principles (para. 66). Retrospective withdrawal of an unlawful administrative act that has created individual rights is permissible, if the institution that adopted the act complies with the conditions relating to reasonable time limits and the legitimate expectations of beneficiaries of the act who have been entitled to rely on its lawfulness. Since the BoA did not describe either the contested goods and services or their characteristics, it failed to state why the sign was not descriptive (para. 78). Furthermore, the EUTM proprietor could not have legitimate expectations relying on the decision's lawfulness (para. 82). Withdrawal of an unlawful decision is compatible with the principle of good administration and legal certainty (paras 83-85). This general principle cannot infringe the principle of res judicata, since administrative decisions do not have a res judicata effect (para. 86). Following the principle of good administration, the fact that the BoA should have based its revocation decision on this general principle and not on Article 80(1) of Regulation (EC) No 207/2009 will not lead to the annulment of the act, since that error does not affect the content of the decision (para. 91). **On the failure to state reasons.** By stating that its decision should be revoked because it was vitiated by a failure to state reasons that constituted a manifest error of procedure, the BoA provided the reasons for its revocation decision (para. 98).



### 3. *General principles of European Union Law*

[No entry]

## B. Procedure before Boards of Appeal

### 1. *Admissibility*

#### 1.1. *Right to appeal, form, deadline*

♦[T-272/17](#); **Dating Bracelet (fig.)**; *Webgarden Szolgáltató és Kereskedelmi Kft v EUIPO*; Judgment of 20 March 2018; EU:T:2018:158; Language of the case: HU. The applicant sought to register the figurative mark ‘Dating Bracelet’ as an EUTM for goods and services in Classes 9, 41, 42 and 45. The Office refused the registration of the EUTM application pursuant to Article 7(1)(b) and (c) EUTMR. The EUTM applicant appealed and the Board of Appeal dismissed the appeal. It found that the mark was descriptive and non-distinctive. The EUTM applicant filed an action before the General Court (GC) relying on three pleas in law: (i) infringement of Article 4 EUTMR, (ii) infringement of Article 7(1)(b) and (c) EUTMR and (iii) infringement of the principles of equal treatment and legal certainty. **Admissibility.** The plea under Article 4 EUTMR is inadmissible as it was not supported by any argument, in breach of Article 177(1)(d) of the Rules of Procedure of the General Court (para. 16).

♦[T-488/17](#); **Dry Zone**; *Ghost — Corporate Management SA v EUIPO*; Judgment of 20 September 2018; EU:T:2018:571; Language of the case: PT. The applicant sought to register the word mark **Dry Zone** as an EUTM for goods in Classes 3, 5, 10 and 16. The Office partially refused the trade mark applied for on the grounds that it did not comply with the provisions of Article 7(1)(b) and (c) and Article 7(2) EUTMR. The applicant filed an appeal. The Board of Appeal (BoA) dismissed the appeal. It found that the appeal was inadmissible due to the fact that it was lodged after the time limit laid down in Article 68 EUTMR. The applicant brought an action before the General Court (GC), relying on three pleas in law: (i) infringement of Article 68 EUTMR and Article 69 EUTMDR, (ii) infringement of the principle of proportionality and (iii) infringement of the principles of legitimate expectations and legal certainty. **As regards the alleged infringement of Article 68 EUTMR.** Since the appeal was received by the Office on 4 April 2017, it was lodged after the expiry, on 3 April 2017, of the two-month period laid down in Article 68 EUTMR (para. 35). The applicant did not provide proof, which was incumbent on it, that the delivery time of the letter was the decisive cause of its failure to meet the time limit, in the sense that it was an event of an inevitable nature against which it could not have protected itself. It follows from the above considerations that the existence of a case of force majeure or exceptional circumstances has not been established (paras 46-47). **On the allegation of infringement of the principle of proportionality.** The applicant did not invoke any argument specifically related to this principle (para. 48). (ii) Article 68 EUTMR must be interpreted as meaning that the date to be taken into account for compliance with the time limit to file an appeal is not the date on which the appeal was sent, but the date on which it was received by the Office. **On the alleged infringement of the principles of legitimate expectations and legal certainty.** The applicant cannot rely on the principle of protection of legitimate expectations in order to seek the annulment of the contested decision (paras 54-55). It is the principle of legal certainty itself which underlies the BoA’s interpretation of Article 68 EUTMR. It follows that the applicant cannot rely on this principle to challenge the interpretation (para. 56).



♦ **T-30/18; Support pillows; Yados.r.o. v EUIPO**; Judgment of 13 December 2018; EU:T:2018:962; Language of the case: SK

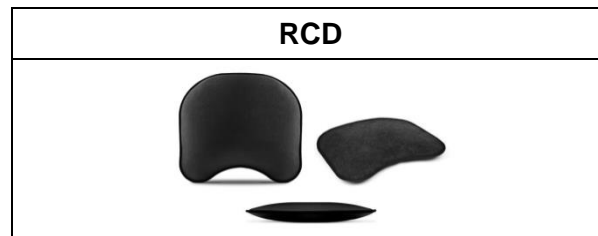

The applicant applied for registration of the Community design (RCD) above. A declaration of invalidity of the RCD was filed pursuant to Article 25(1)(b) CDR. The Invalidity Division (ID) rejected the application because of its lack of novelty. The applicant filed an appeal against the ID's decision and the Board of Appeal (BoA) dismissed the appeal as inadmissible due to the fact that the written statement setting out the grounds of appeal was received after the time limit, expiring on 17 July 2017. The applicant filed an action with the General Court (GC), relying on three pleas in law: (i) infringement of Article 57 CDR and Article 65(1) CDIR and infringement of principles of legal certainty and proportionality, (ii) infringement of the fundamental right to be heard and the deprivation of the possibility of legal proceedings and, (iii) infringement of the fundamental principles laid down in the CDR. The GC annulled the BoA decision. It found in substance that there is no legal obligation for the parties in the procedure before the Office to send documents in the relevant proceedings to the Office's official general fax number (paras 27-28). According to the GC, in the case in question, the applicant has established having sent a five-page document on 17 July 2017 to a fax number from which the ID sent its decision. The Office does not dispute that it received, on 17 July 2017, a five-page document sent to said fax number (para. 25). The GC concluded that the transmission report of 17 July 2017 demonstrated to the requisite legal standard that the applicant had filed the written statement setting out the grounds of appeal within the prescribed period. The date of dispatch of this document was 17 July 2017, the fax number of the addressee was used for the notification of the ID's decision, and the number of pages sent was five, which corresponds to the number of pages of the written statement of grounds of appeal, received two days later at the official general fax number. The result of the transmission was indicated as 'OK', without any error messages having been reported (paras 32 and 34). Although from a legal point of view, the burden of proof that the Office was able to inspect the content of the documents sent on 16 and 17 July 2017 should be borne by the applicant, the factual evidence on which the applicant relies in this case is of such a kind as to require the Office to provide an explanation or justification of not receiving the documents concerned, failing which it is permissible to conclude that the burden of proof has been discharged (para. 35). Consequently, the written statement setting out the grounds of appeal was filed within the prescribed period, so the BoA wrongly concluded that the appeal was inadmissible (para. 36).

### **1.2. New facts, arguments, grounds or evidence**

**C-634/16 P; FITNESS; EUIPO v European Food**; Judgment of 24 January 2018; EU:C:2018:30; Language of the case: EN. The EUTM proprietor was granted the registration of the word mark 'FITNESS' as an EUTM for goods and services in Classes 29, 30 and 32. An application for invalidity was filed pursuant to Article 59(1)(a) EUTMR in



conjunction with Article 7(1)(b) and (c) EUTMR. The Cancellation Division (CD) dismissed the application for invalidity since the applicant failed to prove the descriptive and non-distinctive character of the mark at the relevant point in time. The Board of Appeal (BoA) dismissed the invalidity applicant's appeal and disregarded the evidence submitted for the first time before the BoA since it was belated and new, applying by analogy the third subparagraph of Rule 50(1) of Regulation 2868/95 in conjunction with Rule 37(b)(iv) of that Regulation. The invalidity applicant filed an action before the General Court (GC) relying on, inter alia, infringement of Article 95 EUTMR, read in conjunction with Rules 37(b)(iv) and 50(1) of Regulation 2868/95. The GC upheld the action. It found that Article 95 EUTMR, read in conjunction with Rule 37(b)(iv), does not imply that evidence submitted for the first time before the BoA must be regarded as belated in invalidity proceedings based on an absolute ground for refusal and that Rule 50(1) Regulation 2868/95 should not be applied by analogy. The EUIPO filed an appeal before the Court of Justice of the European Union (CJ) relying on two pleas in law: (i) infringement of Article 95 EUTMR, read in conjunction with Rule 50(1) Regulation 2868/95, and (ii) imbalance in the parties' procedural rights and infringement of the principles of procedural economy and sound administration. The CJ dismissed the appeal. **Time limit for the submission of evidence.** In the context of invalidity proceedings based on absolute grounds for invalidity, even if no time limit is set by which to apply for the cancellation of the registration of a mark, a time limit is nevertheless set for the submission of evidence in the context of the application for a declaration of invalidity or may be set by the EUIPO, by virtue of its competence to organise the procedure (para. 32). The GC erred in stating that Regulation 207/2009 contains no provision fixing a time limit for the submission of evidence (para. 33). **Belated evidence.** Article 95 EUTMR does not imply that evidence submitted for the first time before the BoA must be considered to be out of time in all circumstances (paras 35-45). **Scope of application of 3rd subparagraph of Rule 50(1) Regulation 2868/95.** The third subparagraph of Rule 50(1) of Regulation 2868/95 constitutes a special rule derogating from the principle according to which the provisions relating to proceedings before the department which has made the decision against which the appeal is brought are to be applicable to the appeal proceedings *mutatis mutandis*. That special rule is specific to appeal proceedings brought against the decision of the Opposition Division and is not applicable in the context of invalidity proceedings based on absolute grounds for invalidity (para. 48-49). **Discretionary power.** The discretionary powers conferred on the EUIPO by Article 95 EUTMR, according to which it may decide to disregard or take into account facts and evidence submitted after a deadline has expired, is in no way a favour granted to one party, but must result from an objective, reasoned exercise of that discretionary power (paras 56-58).

♦ **T-105/16; Raquel Superior Quality Cigarettes FILTER CIGARETTES (fig.); Philip Morris Brands Sàrl v EUIPO**; Judgment of 1 February 2018; EU:T:2018:51; Language of the case: EN. The intervener registered an EU figurative sign for the goods in Class 34 (*tobacco pouches; tobacco; smoking tobacco; tobacco, cigars and cigarettes; manufactured tobacco*). The applicant filed an application for a declaration of invalidity of the mark at issue on 13 earlier figurative marks. The Cancellation Division (CD) rejected the application for a declaration of invalidity having first compared the contested trade mark and the earlier international registration and found that the low similarity between the signs did not lead to a likelihood of confusion (LOC) regarding Article 8(1)(b) and Article 8(5) EUTMR and that furthermore, the applicant had not submitted any evidence to establish the reputation of the earlier mark. The applicant filed a notice of appeal against the CD's decision and submitted evidence to prove reputation of the earlier mark. The Board of Appeal (BoA) dismissed the appeal and rejected the applicant's arguments on the grounds that: (i) the dominant elements of the figurative signs at issue were the word elements 'Marlboro' and 'Raquel';



(ii) it could not take into account evidence submitted for the first time before it; (iii) the applicant's arguments alleging infringement of Article 8(5) EUTMR as the evidence of the reputation of the earlier mark had been adduced for the first time before the BoA and, therefore, as the evidence was not supplementary or additional to evidence that had already been submitted it could not be taken into account. The applicant raised three pleas in law: (i) infringement of Article 95(2) EUTMR; (ii) infringement of Article 8(1)(b) and 95(1) EUTMR; (iii) infringement of Article 8(5) EUTMR. The GC quoted the case-law on the discretionary power of the BoA to take into account belated evidence, including that it only extends to evidence which is additional or supplementary to evidence already lodged within the original time limit. The GC confirms that the evidence was not additional or supplementary but completely new. In those circumstances, the BoA was, in principle, not required to take that evidence into account (para. 48). However, the BoA had knowledge of a previous decision in which the earlier mark was found to have reputation. This decision is not, in itself, sufficient to demonstrate the reputation of the earlier mark automatically. However, this decision was a clear indication that the mark might have reputation (para. 65). The Office is under a duty to exercise its powers in accordance with the general principles of EU law, such as the principle of sound administration. It is in the interests of the sound administration of justice that the BoA is able to make a fully informed decision when ruling in proceedings brought before it. Therefore, it is for the BoA to examine with care and impartiality all the factual and legal information necessary for the exercise of its discretion (para. 63). The evidence was likely to be genuinely relevant to the outcome of the proceedings and by refusing to examine the evidence on the ground that it was submitted out of time, the BoA failed to examine a potentially relevant factor in the application of that provision. Notwithstanding the interpretation of Rule 50 of Regulation No 2868/95 and Article 95(2) EUTMR, the broad discretion enjoyed by the Office in the performance of its duties cannot exempt it from its duty to assemble all the elements of fact and law necessary for the exercise of its discretion where the refusal to take account of certain evidence submitted late would breach the principle of sound administration (para. 67). Consequently, the BoA should have taken the new evidence into account. This would not have resulted in a breach of the principle of equality of arms because the other party had the chance to comment on the evidence in the proceedings before the BoA (and in this case, they actually did comment on it). This error of the BoA cannot be corrected by its conclusion that, in any event, even if the reputation had been proved the outcome of the decision would not be different as the degree of similarity between the marks was not sufficient for the successful application of Article 8(5) EUTMR. As the existence of the link for the purposes of Article 8(5) EUTMR must be assessed globally, and the similarity between the marks is only one applicable factor, with the strength of the earlier mark's reputation also needing to be considered, the application of Article 8(5) EUTMR could not have been excluded by the BoA.

♦[C-418/16 P](#); **mobile.de**; *mobile.de GmbH v EUIPO*; Judgment of 28 February 2018; EU:C:2018:128; Language of the case: DE. The EUTM proprietor was granted the registration of the EU word mark **mobile.de** and the figurative mark 'mobile.de' as EUTMs for goods and services in Classes 9, 16, 35, 38 and 42. Two applications for invalidity were filed pursuant to Article 60(1)(a) EUTMR, relying on the earlier Bulgarian figurative mark 'mobile' covering services, inter alia, in Classes 35 and 42. The Cancellation Division (CD) dismissed both applications, on the ground that proof of use of the earlier mark was not provided. The CD's decisions were appealed and the Board of Appeal (BoA) found proof of genuine use of the earlier Bulgarian mark, but only for *advertising services for motor vehicles* in Class 35 and upheld the appeal. Since the CD had not examined likelihood of confusion, the BoA referred the case to the CD for examination. The EUTM proprietor filed two actions against the BoA's decisions before the General Court (GC), which dismissed



both. The EUTM proprietor filed an appeal before the Court of Justice of the European Union (CJ). **Discretion of the BoA.** The GC was right in finding that the BoA is entitled, when examining an appeal directed against a decision of the CD, to take into account additional evidence of genuine use of the earlier mark not produced within the set time limits (para. 62). The GC examined not only whether the evidence produced late had any real relevance, but also whether the stage of the proceedings at which the late submission took place and the surrounding circumstances precluded the taking into account of such evidence (para. 64). The GC has exclusive jurisdiction to find and appraise the relevant facts and to assess the evidence. On the contrary, the CJ, upon appeal, has no jurisdiction on the factual assessment, except when facts and evidence are distorted (para. 65). In this case, the EUTM proprietor, rather than seeking to establish distortion of facts and evidence regarding the invoices submitted before the CD, apparently seeks to have the CJ re-examine whether the invoices produced for the first time before the BoA were intended to reinforce and clarify the content of the evidence produced before the CD (para. 67).

♦**C-478/16 P**; **GROUP Company TOURISM & TRAVEL (fig.) / GROUP Company TOURISM & TRAVEL (fig.)**; *EUIPO v Group ODD*; Judgment of 19 April 2018; EU:C:2018:268; Language of the case: BG. The applicant sought to register the figurative mark shown ‘GROUP Company TOURISM & TRAVEL’ as an EUTM for services in Classes 35, 39 and 43. An opposition was filed based on an earlier non-registered figurative sign ‘GROUP Company TOURISM & TRAVEL’, used in Bulgaria, Czechia, Hungary, Poland and Slovakia as a company name for transportation services. The Opposition Division (OD) dismissed the opposition insofar as the opponent had not specified or provided any evidence about the applicable national law on which it was relying and under which the use of the mark sought might have been prohibited in the Member States concerned. The opponent filed an appeal and submitted references to Bulgarian law. The Board of Appeal (BoA) dismissed the appeal, as it found that the documents produced by the applicant before the OD did not contain any reference to Bulgarian law. The BoA found that the references to three legal provisions in the statement of grounds of appeal, had been submitted late. According to the BoA, the required reference to the legal bases must be made within the time limits granted during opposition proceedings. It also found that the applicant had referred only to the text of Article 12(1) of the Bulgarian law on trade marks and geographical indications, without providing the original Bulgarian version or proving that that text originated from an official and reliable source. The opponent filed an action before the General Court (GC) relying on three pleas in law: (i) infringement of Article 95(1) EUTMR, (ii) infringement of Article 95(2) EUTMR, and (iii) infringement of Article 8(4) EUTMR. The GC upheld the action insofar as it found that the **particulars of the national legislation** supplemented the initial evidence which concerned the use in the course of trade of an unregistered sign, with both sets of evidence being regarded together as ‘one piece of evidence proving the acquisition, permanence and the scope of the protection of an earlier right’. Therefore, the BoA could not rule out the admissibility of the content of the national law, submitted for the first time before it, without exercising its discretion under Article 95(2) EUTMR. Furthermore, the BoA could not require the opponent to produce an extract from the Darzhaven vestnik or the official Bulgarian text. If the BoA had doubts about the faithful reproduction, applicability or interpretation of the Bulgarian law relied on by the applicant, it was required to exercise its powers of verification. The Office filed an action before the Court of Justice of the European Union (CJ) relying on two pleas in law: (i) infringement of Article 95(2) EUTMR in conjunction with Rule 50(1) of Regulation No 2868/95 and (ii) infringement of Article 8(4) EUTMR in conjunction with Article 7(2)(d) EUTMDR. (i) Regarding the first plea concerning the alleged infringement of Article 95(2) EUTMR in conjunction with Rule 50(1) of Regulation No 2868/95, the Court of Justice recalled that, when evidence is produced within the time



limit set by the Office, the presentation of supplementary evidence remains possible (para. 37). The additional elements must be regarded as complementary rather than ‘new’, since together they form part of the evidence used to prove the acquisition, permanence and the scope of protection of the non-registered Bulgarian mark (para. 38). Moreover, the additional evidence was related to evidence previously submitted before the OD, since the Bulgarian law was indispensable for the assessment of the proof of use of the earlier non-registered sign, and vice versa (paras 42-43).

♦[T-288/16](#); **M'Cooky / MR. COOK (fig.)**; *Convivo GmbH v EUIPO*; Judgment of 26 April 2018; EU:C:2018:231; Language of the case: EN. The IR holder designated the EU for ‘**M'COOKY**’, covering goods and services in Classes 30 and 43. An opposition based on the earlier Spanish figurative mark ‘MR. COOK’, registered for goods in Classes 29, 30 and 31, was filed pursuant to Article 46 EUTMR. The Opposition Division (OD) partly upheld the opposition. The Board of Appeal (BoA) dismissed the IR holder’s appeal. The IR holder appealed to the General Court (GC) to annul the BoA’s decision, relying on a single plea in law, namely, infringement of Article 8(1)(b) EUTMR, submitting that the marks were not visually, phonetically or conceptually similar. **Admissibility of evidence adduced for the first time before the court.** A document, such as a dictionary extract, which substantiates a factual matter of common knowledge which was not established in the EUIPO’s contested decision, is admissible (para. 26).

♦[C-85/16 P](#) and [C-86/16 P](#) (joined cases); **KENZO ESTATE / KENZO**; *Kenzo Tsujimoto v EUIPO*; Judgment of 30 May 2018; EU:C:2018:349; Language of the case: EN. The IR holder designated the EU for two word marks **KENZO ESTATE** covering, respectively, goods in Class 33 and goods and services in Classes 29, 30, 31, 35, 41 and 43. Two oppositions based on the earlier word mark **KENZO**, registered for, inter alia, goods in Classes 3, 18 and 25 were filed by the opponent pursuant to Article 8(5) EUTMR against all the goods and services for which protection was sought. The Opposition Division (OD) dismissed both oppositions. The Board of Appeal (BoA) fully upheld the opponent’s appeal to which Case C-85/16 P refers and partially upheld the appeal to which Case C-86/16 P refers. The IR holder brought two actions before the General Court (GC) for the annulment of the BoA decisions. The GC dismissed both appeals. The IR holder filed two appeals before the Court of Justice of the European Union (CJ) relying on two pleas in law: infringement of Article 95(2) and of Article 8(5) EUTMR. Cases C-85/16 P and C-86/16 P were joined for the purposes of the procedure and of the judgment. The CJ dismissed the appeals. **On the first plea in law:** the CJ reiterates the case-law whereby the BoA enjoys discretion under Article 95(2) EUTMR, in connection with Rule 50(1) of Regulation 2868/95, to decide whether or not to take into account additional or supplementary facts or evidence that were not submitted within the time limits set by the OD (para. 44). The CJ endorsed the GC’s findings, according to which proof of use and proof of reputation are indissociably linked and that only an excessive and illegitimate formalism would dictate that the proof of use could not be adduced as proof of reputation (para. 47).

♦[T-24/17](#); **D-TACK / TACK et al.**; *LA Superquimica, SA v EUIPO*; Judgment of 10 October 2018; EU:T:2018:668; Language of the case: EN. The predecessor of D-Tack GmbH sought to register the word mark ‘D-TACK’ for the goods and services in Classes 1, 17 and 35. An opposition was filed based on six Spanish earlier rights, pursuant to Article 5 EUTMR and Article 8(1)(b) EUTMR. The Opposition Division (OD) rejected the opposition in its entirety because proof of the earlier marks had not been provided and the evidence of use of the earlier mark was insufficient. The opponent appealed against the OD’s decision. The Board of Appeal (BoA) dismissed it as the evidence provided showed use that altered the distinctive character of the earlier mark as registered. The opponent filed an action with





the General Court (GC), relying on two pleas in law: (i) infringement of the rules on the substantiation of the registrations of the earlier marks and (ii) infringement of the rules on proof of use of the earlier word mark **TACK**. **On the alleged infringement of the rules on the substantiation**. The BoA exercised its discretion and considered, rightly, that the new extracts from the Sitadex database could not be taken into account, highlighting the legitimate interest of the applicant, whose behaviour in no way influenced the belated filing of the extracts (paras 27-28).

## 2. Essential procedural requirements

### 2.1. Right to be heard

**T-222/16; MAGELLAN**; *Hansen Medical, Inc. v EUIPO*; Judgment of 27 February 2018; EU:T:2018:99; Language of the case: EN. The word mark **MAGELLAN** was registered as an EUTM for goods and services in Class 10. An application for revocation was filed pursuant to Article 58 EUTMR. The Cancellation Division (CD) dismissed the application for revocation for *medical apparatus and instruments, namely injection devices and their components for all manner of injection, collection and transfer of tissue and fluids*, and granted the application for revocation for the following goods: *surgical, dental and veterinary apparatus and instruments*. Both the invalidity applicant and the EUTM applicant filed an appeal before the Board of Appeal (BoA), which dismissed the invalidity applicant's appeal and upheld the EUTM applicant's appeal. It annulled the CD's decision in part insofar as it revoked the contested mark for *surgical, dental and veterinary apparatus and instruments*. The invalidity applicant filed an action before the General Court (GC), relying on five pleas in law: (i) infringement of Article 18 and Article 58(1)(a) EUTMR, (ii) infringement of Article 64(1), Article 70(2), Article 94 and Article 95 EUTMR, (iii) infringement of Article 71 EUTMR, (iv) infringement of Article 94 EUTMR, and (v) infringement of Article 96 EUTMR. **On the first plea in law**. The BoA was fully entitled to find that the contested mark did not cover *surgical, medical, dental and veterinary apparatus and instruments* as four separate categories, but, because of the term 'namely', was referring to a dedicated subgroup of goods consisting of *injection devices and their components for all manner of injection, collection and transfer of tissue and fluids* (para. 30). Evidence of genuine use of the contested mark for *medical apparatus and instruments, namely, injection devices and their components for all manner of injection, collection and transfer of tissues and fluids* was given. None of the evidence demonstrates that an injection device used in medical procedures differs from an injection device used in dental, surgical or veterinary procedures (paras 31-32). **On the second plea in law**. The BoA was right to find that the CD's decision would not have been different in the absence of the procedural error committed by it (by depriving the applicant of the opportunity to submit its observations on the additional evidence that it had accepted) (paras 38 and 41). **On the third plea in law**. Although the BoA does refer to the CD's reasons as to the proof of genuine use of the contested mark, it nevertheless conducted its own analysis. It found that the evidence submitted before the CD was sufficient to prove not only the genuine use of the contested mark for *medical apparatus and instruments, namely injection devices and their components for all manner of injection, collection and transfer of tissues and fluids*, but also for all the goods for which the mark had been registered (para. 45). **On the second fourth in law**. The duty to state reasons does not require the BoA to provide an account that follows all the lines of reasoning articulated by the parties exhaustively and one by one. The BoA set out the facts and the legal considerations having decisive importance in the context of the decision: it explained that the injection devices for which use had been proved did not form a subgroup of goods corresponding to a single general term on a list of



goods, but instead formed a subgroup of goods of both *medical apparatus and instruments* and of *dental, veterinary and surgical apparatus and instruments* (paras 50-51). **On the fifth plea in law.** The BoA exercised its discretion by finding that it was in possession of all the information required as a basis for the operative part of the contested decision (para. 59).

♦[T-721/16](#); **BeyBeni (fig.) / Ray-Ban (fig.) et al.**; *Luxottica Group SpA v EUIPO*; Judgment of 8 May 2018; EU:T:2018:264; Language of the case: ES. The EUTM applicant sought to register the figurative sign ‘BeyBeni’ for goods in Classes 9, 14 and 18. An opposition based on the earlier figurative trade mark ‘Ray-Ban’ was filed pursuant to Article 8(1)(b) and Article 8(5) EUTMR for all the abovementioned goods. The Opposition Division (OD) upheld the opposition pursuant to Article 8(1)(b) EUTMR for all the goods applied for in Classes 14 and 18 and for part of the goods applied for in Class 9. For the remaining Class 9 goods (*apparatus, instruments and cables for electricity, safety, security, protection and signalling devices; devices for treatment using electricity; photovoltaics...*), the opposition was dismissed, pursuant to Articles 8(1)(b) and Article 8(5) EUTMR, as sunglasses and *eyeglass frames* (for which reputation was proved) are not close enough to such goods for the public to establish a link. The applicant appealed the OD’s decision, and the Board of Appeal (BoA) dismissed the appeal. It found that there was only a very small degree of similarity between the signs at issue, and the *sunglasses* and *spectacle frames* did not have sufficient proximity to the goods concerned for a link between the marks at issue to be established in the mind of the relevant public. The EUTM applicant appealed to the General Court (GC) relying on two pleas in law: (i) infringement of Article 70(2) and 94 EUTMR and (ii) infringement of Article 8(5) EUTMR. **The right to be heard.** The OD’s conclusions on the degree of similarity of the signs were not appealed before the Board, therefore the BoA should not have examined this question: the BoA re-examined the substance of the opposition pursuant to Article 8(5) EUTMR, both in law and in fact and analysed the relevant criteria. Since the degree of similarity is one of the criteria laid down in this article, the BoA was right to make its own analysis (para. 20). Moreover, the BoA was not required to hear the applicant again on the degree of similarity before delivering its own assessment, as the applicant had already made its own observations. That decision therefore did not affect the applicant’s right to be heard or its right of defence (para. 25). Finally, by rejecting the applicant’s appeal, the BoA upheld the decision of the OD. Accordingly, insofar as the OD had not upheld the applicant’s claims, the applicant was not, following the contested decision, in a less favourable legal position than before the appeal (paras 27-28). So the applicant was wrong in arguing that the BoA was required to hear it prior to its decision on the degree of similarity of the signs at issue before adopting a position which differed from that of the OD (para. 29).

♦[T-803/16](#); **SALMEX (fig.)**; *Glaxo Group Ltd v EUIPO*; Judgment of 6 June 2018; EU:T:2018:330; Language of the case: EN. The applicant sought a declaration of invalidity for the contested EUTM based on earlier national shape marks registered for goods in Classes 5 and 10. The earlier national marks specifically included the French trade mark registered, inter alia, for *inhalers* in Class 10. This was pursuant to Article 60(1)(a) EUTMR in conjunction with Article 8(1)(b) and Article 8(5) EUTMR. The EUTM proprietor requested proof of use of the earlier marks. The Cancellation Division (CD) upheld the application for invalidity as it found: (i) that genuine use of the earlier French mark had been established regarding inhalers and; (ii) likelihood of confusion existed between the conflicting marks. Upon the EUTM proprietor’s appeal, the Board of Appeal (BoA) upheld the appeal and annulled the CD’s decision on the ground that it found that no genuine use of the earlier mark had been established. However, the BoA examined the issue of genuine use of the earlier marks by its own motion. The applicant filed an action for annulment of the BoA



decision before the General Court (GC). The GC confirmed previous case-law, stating that the issue of genuine use of earlier marks is a specific and preliminary question, which must be specifically raised by the parties before the BoA to become the subject matter of the appeal (paras 27 and 31). Therefore, by examining and deciding upon the issue of genuine use, in the absence of any request made to that effect by the parties to the proceedings before it, the BoA infringed Article 71(1) EUTMR (para. 17). Therefore, the BoA acted outside its competence (para. 31). As this is a matter of public policy, it must be raised by the GC *ex officio* even in the absence of any request to that effect by the applicant for annulment (para. 21).

♦♦[T-164/17](#); **WILD PINK / PINK LADY et al.**; *Apple and Pear Australia Ltd v EUIPO*; Judgment of 15 October 2018; EU:T:2018:678; Language of the case: EN. The applicant sought to register the word mark ‘WILD PINK’ as an EUTM for goods in Classes 29 to 31. An opposition, based on the earlier EU and national (Benelux, German, UK, French) word marks ‘PINK LADY’ as well as the earlier EU figurative marks ‘Pink Lady (fig.)’, registered for goods in Classes 29 to 31, was filed pursuant to Article 8(1)(b) EUTMR and Article 8(5) EUTMR. The Opposition Division (OD) dismissed the opposition and the opponent filed an appeal. The Board of Appeal (BoA) dismissed the appeal without assessing any reputation the earlier marks may enjoy, since it found them to be dissimilar to the mark applied for. The opponents filed an action before the General Court (GC), relying on four pleas in law: (i) infringement of Article 95(1) EUTMR, (ii) infringement of Article 94 EUTMR and Article 296 TFEU, (iii) infringement of Article 8(1)(b) EUTMR and (iv) infringement of Article 8(5) EUTMR. **Examination of the facts and right of defence.** The considerations concerning the pinkish-red colour of apples do not stem from the BoA acting on its own initiative and are in fact based on facts and evidence submitted by the parties (para. 22). The opponents were perfectly able to dispute the conclusions relating to the colour of the apples before the Office and their right of defence were not in any way infringed (para. 27). As to the BoA’s comment regarding ‘a short visit to any local fruit market’, it is a supplementary statement that was made for the sake of completeness (para. 28).

♦♦[T-8/17](#); **GOLDEN BALLS / BALLON D’OR et al.**; *Golden Balls Ltd v EUIPO*; Judgment of 17 October 2018; EU:T:2018:692; Language of the case: FR. The applicant sought to register the word mark **GOLDEN BALLS** as an EUTM for goods and services in Classes 9, 28 and 41. An opposition based on the earlier word mark **BALLON D’OR**, registered for goods and services in Classes 9, 28 and 41, was filed pursuant to Article 8(1)(b) EUTMR and Article 8(5) EUTMR. The Opposition Division (OD) rejected the opposition in its entirety. The opponent filed an appeal. The Board of Appeal (BoA) annulled the OD’s decision, finding likelihood of confusion (LOC) for all of the goods except *apparatus and instruments for conducting, switching, transforming, accumulating, regulating or controlling electricity* in Class 9. Grounds under Article 8(5) EUTMR were not examined. The applicant filed an action with the General Court (GC) pursuant to Article 8(1)(b) EUTMR and the opponent filed a cross-claim pursuant to Article 8(5) EUTMR. In T-448/11, the GC upheld the applicant’s action and rejected the opponent’s cross-claim. The opponent appealed to the Court of Justice (CJ). In C-581/13 P & C-582/13 P, the CJ annulled the GC’s judgment insofar as it concerned the dismissal of the opponent’s cross-claim. The case was remitted to the BoA, which noted that the specification of the trade mark application had been restricted by deleting *apparatus and instruments for conducting, switching, transforming, accumulating, regulating or controlling electricity* in Class 9 and that the refusal of the opposition based on Article 8(1)(b) EUTMR was already final. It therefore remitted the case to the OD for examination on the grounds of Article 8(5) EUTMR. The OD partially upheld the opposition on Article 8(5) EUTMR for some of the goods and services. The applicant also appealed against this decision, insofar as it rejected the trade mark application. The



opponent filed a cross-appeal, seeking revision of the OD's decision pursuant to Article 8(3) of Regulation (EC) No 216/96 for the goods and services that had not been rejected. The BoA dismissed the applicant's appeal, upheld the opponent's cross-appeal and rejected the EUTM application in its entirety. The applicant filed an action with the GC, relying on four pleas in law: (i) infringement by the BoA of the authority of res judicata, (ii) that the BoA had exceeded the subject matter of the appeal before it, thus infringing the applicant's right of defence, (iii) that the BoA failed to take into account developments after the filing of the EUTM application and (iv) infringement of Article 8(5) EUTMR. The ground for opposition of Article 8(5) EUTMR was still pending for all the goods and services referred to, with the exception of those for which the applicant had withdrawn its application for registration, on the dates on which the BoA's second decision, the OD's second decision and the BoA's contested third decision were adopted by the Office. The first plea must be rejected as unfounded (paras 46-53). The applicant was not invited to file observations on the opponent's appeal seeking revision of the OD's decision pursuant to Article 8(3) of Regulation (EC) No 216/96. By annulling the second OD decision to the extent requested by the opponent, the BoA infringed Article 94 EUTMR. The contested decision is annulled insofar as it upheld the opponent's appeal seeking revision of the OD's decision (paras 61-68). The reputation of the earlier mark must be examined at the time when the contested EUTM application was filed (para. 77).

♦ **T-359/17; ALDI / ALDO (fig.); Aldo Supermarkets v EUIPO**; Judgment of 25 October 2018; EU:T:2018:720; Language of the case: EN. The applicant sought to register the word mark **ALDI** as an EUTM for, inter alia, services in Class 35. An opposition was filed pursuant to Article 8(1)(b) and Article 8(5) EUTMR, based on the earlier Bulgarian figurative mark 'ALDO'. This mark appeared in colour in the opposition notice and also in a separate document, also in colour, although this additional document did not indicate its origin. The Office found the opposition admissible and invited the opponent to substantiate the earlier right. During the substantiation period, the opponent submitted a black and white copy of the registration certificate of the Bulgarian mark and a translation of that document, including a translation of the colours of the earlier mark, into the language of proceedings. The Opposition Division (OD) partially upheld the opposition. However, the BoA rejected it as unsubstantiated. The opponent appealed to the General Court (GC), relying on four pleas in law: (i) infringement of Article 7 EUTMDR and of the principle of legal certainty, (ii) contradictory reasoning, (iii) infringement of the rights of the defence and of the principle of the right to be heard and (iv) infringement of Article 47(2) EUTMR and Article 10(3) and (4) EUTMDR. **On the right to be heard.** (iii) In the information note attached to its letter, the Office had informed the opponent that the registration certificate or an equivalent official document had to be submitted as evidence of the existence of the earlier right, and that this document had to include a representation of the mark as registered, that is to say, in colour if appropriate (para. 70). Further, the evidence of the existence, validity and scope of protection of a mark to be submitted during opposition proceedings is set out precisely and exhaustively in Article 7 EUTMDR, so that an opponent is in a position to be aware, even before filing its notice of opposition, of the specific documents it must produce in support of that opposition (para. 69). Moreover, in this case, as the applicant had challenged the circumstances surrounding the representation of the earlier mark before and/or during OD and BoA proceedings, the opponent had had ample opportunity to provide the registration certificate or another equivalent official document (paras 71-72, 75). The BoA is not empowered to provide guidance as regards the production of evidence nor to assist an opponent in proving the facts, evidence or arguments it must produce to demonstrate the existence of its earlier right (para. 74). (iv) Since proof of the earlier mark had not been adduced, there was no need to examine the fourth plea, that the earlier mark was used for the goods and services for which registration was granted, since it was ineffective



(para. 79).

♦[T-460/17](#); **DARSTELLUNG EINES GLEICHWINKLIGEN ACHTECKS**; *Carsten Bopp v EUIPO*; Judgment of 21 November 2018; EU:T:2018:816; Language of the case: DE

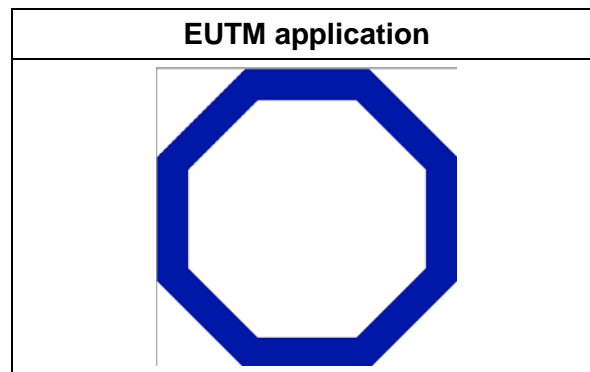

The applicant sought to register the figurative mark above claiming the colour 'blue' as an EUTM for the goods and services in Classes 16, 42 and 45. The examination proceedings were stayed until the final outcome on the registrability of the applicant's parallel EUTM application for a green octagonal frame. When the Court of Justice (C-653/15) dismissed the appellant's appeal regarding the latter, confirming that the parallel EUTM application lacked distinctive character, the Office gave the applicant the opportunity to submit observations on the judgment. The Office did not receive any observations. Irrespective of this fact, it refused the EUTM application referring to the ECJ judgment. The applicant appealed, claiming before the Boards of Appeal (BoA) that (i) it submitted observations that were not taken into account, (ii) it was never given the opportunity to submit observations on the claim that the EUTM application was not registrable in part of the EU and (iii) the EUTM application was distinctive. The BoA dismissed the appeal confirming non-distinctiveness of the mark. Taking into account the judgment regarding the green octagonal frame, the Office refused the EUTM application, and therefore it was up to the applicant to prove that the contested mark would be perceived as an indication of the origin. The applicant filed an action before the General Court (GC), relying on two pleas in law: (i) infringement of Article 7(1)(c) EUTMR and (ii) infringement of Article 94 EUTMR. **On the right to be heard.** As to the claim that the Office infringed the applicant's right to be heard by not taking one of its submissions into account, the applicant admitted that it had only saved a draft of its observations in its user account without proceeding to click on the 'confirm' button in order to submit the draft. It failed to show that it had indeed sent its observations producing a receipt on behalf of the Office (para. 40). Therefore, these observations were presented as evidence for the first time before the GC, and were, therefore, inadmissible (para. 49).

♦[T-665/17](#); **CCB (fig.) / CB (fig.) et al.**; *China Construction Bank Corp. v EUIPO*; Judgment of 6 December 2018; EU:T:2018:879; Language of the case: EN. The applicant sought to register the figurative mark 'CCB' as an EUTM for services in Class 36. An opposition based on the earlier EU figurative mark 'CB' registered for services in Class 36 was filed pursuant to Article 8(1)(b) EUTMR. The Opposition Division (OD) upheld the opposition, as it found likelihood of confusion (LOC). The applicant filed an appeal, which was dismissed by the Board of Appeal (BoA). The applicant filed an action with the General Court (GC) relying on two pleas in law: (i) infringement of Article 94(1) and Article 95(1) EUTMR, and (ii) infringement of Article 8(1)(b) EUTMR. **Rights of defence.** Having been a party to the proceedings, the applicant was in a particularly good position to effectively make known its





views on the previous BoA decision on CCB/CB referenced by the intervener, including all of the elements taken into account (para. 25). The BoA did not exceed the limits of the factual basis of its examination in relying on the absence of regular use of the services at issue, and was not under an obligation to hear the applicant on the finding at issue (para. 29).

## 2.2. Duty to state reasons

♦[T-204/16](#); **METABOX / META4 et al.**; *Sun Media Ltd v EUIPO*; Judgment of 16 January 2018; EU:T:2018:5; Language of the case: EN. The applicant sought to register the word mark **METABOX** for the services in Classes 35, 38, 41 and 42. An opposition based on the earlier EU word marks (i) **META4**, (ii) **META4**, (iii) **META4** and (iv) the unregistered Spanish word mark **META4**, registered for the services in (i) Classes 35 and 38; (ii) Class 42; (iii) Class 35, and (iv) for the services corresponding to the following description: *advertising; business management; business administration; office functions; information and advice on human resources and personnel; assistance to businesses relating to human resources organisation and management; payroll preparation and providing external human resource department services; salary data processing, salary calculation, human resource management data processing; retailing in shops and via global computer networks of computer goods and software*, as well as on the earlier EU figurative

mark (v) **meta4!** and (vi) the Spanish figurative mark  registered for the services in (v) Class 42 and (vi) Class 41 was filed pursuant to Article 8(1)(b) EUTMR. The Opposition Division (OD) upheld the opposition in part for the services in Class 41 (*entertainment; cultural and sporting activities; organisation of exhibitions for cultural or educational purposes*) and for all the services in Classes 35, 38 and 42. The opponent appealed against the OD's decision and the Board of Appeal (BoA) dismissed the appeal. It found that the marks had an average degree of visual similarity and some phonetic and conceptual similarity, and that there was a likelihood of confusion for part of the contested services due to a similarity of the signs and an identity or similarity between the services. The applicant raised three pleas in law: (i) infringement of Article 8(1)(b) EUTMR, (ii) infringement of Article 94 EUTMR and (iii) infringement of the general principles of EU law. **On the second plea in law:** the contested decision contains a statement of reasons consistent with the requirements referred to in paras 21 and 22, which made it possible to understand the BoA's reasoning and which made it possible for the applicant to prepare its action (para. 24).

♦[T-273/16](#); **METAPORN / META4 et al.**; *Sun Media Ltd v EUIPO*; Judgment of 16 January 2018; EU:T:2018:2; Language of the case: EN. The applicant sought to register the word mark **METAPORN** as an EUTM for services in Classes 35, 38, 41 and 42. An opposition based on, inter alia, the earlier EU word mark **META4** (Classes 35, 38 and 42), the EU figurative mark  (Classes 38 and 42) as well the Spanish word mark

**META4** (Class 35) and the Spanish figurative mark  (Classes 35 and 41), was filed pursuant to Article 8(1)(b) and (2) EUTMR. The Opposition Division (OD) partly upheld the opposition and refused to register the contested mark for all services in Classes 35, 38 and 42. The applicant filed an appeal, which was dismissed by the Board of Appeal (BoA). It found that there was a likelihood of confusion, at least on the part of the Spanish-speaking public, since the contested services in Classes 35 and 38 were identical and those in Classes 41 and 42 were similar, and given the visual, phonetic and conceptual similarity, as well as the normal degree of distinctiveness of the earlier marks. The applicant



filed an action before the General Court (GC) relying on three pleas in law: (i) Article 8(1)(b) EUTMR, (ii) Article 94 EUTMR, and (iii) infringement of the general principles of EU law. **On lack of reasoning.** The BoA decision contains a sufficient statement of the reasons which made it possible to understand its reasoning and for the applicant to prepare its action (paras 26-27).

♦[T-179/17](#); **NYouX (fig.) / NUXE**; *Laboratoire Nuxe v EUIPO*; Judgment of 21 February 2018; EU:T:2018:89; Language of the case: FR. The applicant sought to register the figurative sign ‘NYouX’ for goods in Classes 8, 11 and 26. An opposition based on the French earlier word mark **NUXE**, registered for goods in Classes 3, 8, 11 and 26 was filed pursuant to Article 8(1)(b) EUTMR. Given the low degree of similarity of the signs and the average degree of distinctiveness of the earlier mark for the goods in Classes 8, 11 and 26, the Opposition Division (OD) dismissed the opposition in spite of the identity/similarity of the goods. OD did not examine the similarity of the *hair-cutting device, hairdryers and hairdressing accessories* in Classes 8, 11 and 26 with cosmetics for which enhanced distinctiveness was claimed. Upon the opponent’s appeal, the Board of Appeal (BoA) dismissed the appeal for the same reasons, without examining whether a different solution could be reached if the contested goods in Classes 8, 11 and 26 were compared to the goods in Class 3, and if the enhanced distinctiveness of the earlier mark for cosmetics was substantiated. The applicant filed an action before the General Court (GC), relying on two pleas in law: (i) infringement of the obligation to state reasons and (ii) infringement of Article 8(1)(b) EUTMR. **Obligation to state reasons.** The BoA observed that the earlier mark has an average intrinsic distinctive character as there is no conceptual link to the goods in question (para. 22). The BoA considered that the visual and oral similarity of the signs was low and there was no conceptual similarity (para. 30), but it also considered that the signs were different overall (para. 35). These two findings cannot be reconciled because if the similarity of the signs was low, it was necessary to carry out an overall assessment of the likelihood of confusion (LOC), whereas it was not necessary if the signs were different (para. 36).

♦[T-424/16](#); **Footwear**; *Gifi Diffusion v EUIPO*; Judgment of 14 March 2018; EU:T:2018:136; Language of the case: EN. The RCD proprietor was granted the registration of a design as an RCD for goods in Class 02-04 of the Locarno Classification (*footwear*). An application for invalidity was filed pursuant to Article 52 CDR in conjunction with Article 25(1)(b) CDR and the invalidity applicant claimed lack of novelty by reason, inter alia, of prior disclosure of various earlier designs. It also claimed lack of individual character because the overall impression it produced was similar to that of designs D 1, D 18a, D 18b and D 19, as well as designs D 20-22. The Invalidity Division (ID) upheld the application for invalidity and declared the contested design invalid due to a lack of individual character in relation to the earlier Community design (D 1). The RCD proprietor appealed and the Board of Appeal (BoA) upheld the appeal stating that the application for invalidity needed to be re-examined ‘in its entirety’. It nevertheless restricted its examination to a comparison between the contested design and designs D 1 to D 17, without expressing a view on designs D 18 to D 22. The invalidity applicant filed an action before the General Court (GC) relying on two pleas in law: (i) infringement of Article 6 CDR and (ii) infringement of Article 62 and Article 63(1) CDR. (i) The Office put forward two grounds: designs D 20 and D 22 were invoked at a later stage of the proceedings, and designs D 18a, D 18b and D 19 were not invoked with sufficient clarity and precision (para. 33). It is not possible, however, to give this additional statement of reasons for the first time before the Court (para. 34). Furthermore, even assuming that the BoA considered that some designs had been invoked late, it was required to give reasons for its decision in that regard (para. 38). Moreover, the application for a declaration of invalidity contained not



only the indication and the reproduction of designs D 18a, D 18b and D 19 but also documents proving the existence of those earlier designs, in the form of screenshots and copies of journals. What is more, the invalidity applicant referred to them both in its observations and before the BoA (para. 39). (ii) The BoA was, in principle, required to examine the contested design in relation to every earlier design duly invoked. Furthermore, the BoA recalled that it was required to re-examine the invalidity application in its entirety. In the absence of any statement of reasons for designs D 18 to D 22, the BoA's decision lacks reasoning (paras 41-42). (iii) The BoA has exceeded the limits of its powers and it has gone beyond the facts, evidence and arguments provided by the parties, since the 'party concerned' had never invoked a ground for invalidity alleging the lack of individual character of the contested design in relation to designs D 2 to D 17, but, on the contrary, had restricted that ground for invalidity to designs D 1 and D 18 to D 22 (para. 47). (iv) The ground for invalidity examined of its own motion by the BoA entailed the assessment of different legal criteria, concerning two separate grounds for invalidity. The BoA itself stated on several occasions that the [invalidity] applicant 'did not give any explanation as to why these clogs should produce the same overall impression as the contested [design]', without taking account of the fact that this absence of explanation was due precisely to the fact that the latter had not invoked that ground for invalidity (para. 48). (v) In the absence of any statement of reasons in the BoA's decision in relation to designs D 18 to D 22, the GC cannot substitute its own reasoning for that of the BoA nor carry out an assessment on which the BoA has not yet adopted a position (para. 51).

♦[T-235/17](#); **MOBILE LIVING MADE EASY**; *Dometic Sweden AB v EUIPO*; Judgment of 22 March 2018; EU:T:2018:162; Language of the case: EN. The applicant sought to register the word mark **MOBILE LIVING MADE EASY** as an EUTM for goods and services in Classes 5 to 7, 9, 11, 12, 19 to 22 and 27. The Office refused the registration of the EUTM application pursuant to Article 7(1)(b) EUTMR, as it was found to be devoid of distinctive character. The applicant appealed and the Board of Appeal (BoA) dismissed the applicant's appeal. The applicant filed an action before the General Court (GC) relying on two pleas in law: (i) infringement of Article 94 EUTMR and (ii) infringement of Article 7(1)(b) EUTMR. The statement of reasons for the contested decision enabled the applicant to understand how the BoA defined a homogenous category of goods and services in relation to which it used general reasoning (para. 20). By stating that the link between all the goods and services is that they 'facilitate mobile life', the BoA found that they all had a characteristic relevant to the examination of the absolute ground for refusal regarding a lack of distinctiveness and that they were all part of a homogenous category (para. 16).

♦[T-648/16](#); **BOBO cornet www.bobo-cornet.com (fig.) / OZMO cornet (fig.)**; *Şölen Çikolata Gıda Sanayi ve Ticaret AŞ v EUIPO*; Judgment of 17 April 2018; EU:T:2018:194; Language of the case: EN. The EUTM applicant sought to register the figurative sign 'BOBO cornet' for goods in Classes 29, 30 and 32. An opposition based on the earlier international registration 'OZMO cornet' was filed pursuant to Article 8(1)(b). It was based on all the goods of the earlier registration, namely goods in Class 30, and directed against all the goods of the EU trade mark application. The Opposition Division (OD) rejected the opposition in its entirety. The opponent filed an appeal which was dismissed by the Board of Appeal (BoA). It found that the signs are visually dissimilar; aurally similar to a less than average degree; and conceptually void and deduced that there was no likelihood of confusion (LOC). The opponent filed an action before the General Court (GC) relying on two pleas in law: (i) infringement of Article 8(1)(b) EUTMR and (ii) infringement of Article 94 EUTMR and, more particularly, breach of the duty to state reasons, infringement of Article 95(1) EUTMR and breach of the duty of diligence. **Breach of the duty to state reasons and of the duty of diligence**: the BoA did not fail to fulfil its duty of diligence as





the statement of reasons for the contested decision as regards the phonetic and conceptual comparison of the signs enabled the applicant to substantiate its case before the GC and enabled the GC to understand the reasoning of the BoA (para. 102). The BoA excluded LOC and did this while assuming that the goods were identical. Therefore, the BoA did not breach its duty of diligence as the lack of a detailed analysis of the goods in question had no consequences in this case (para. 104).

♦ [T-339/15 to T-343/15](#) (joined cases); **STACJA BENZYNOWA (3D)**; *Polski Koncern Naftowy Orlen SA v EUIPO*; Judgment of 16 April 2018; EU:T:2018:192; Language of the case: PL

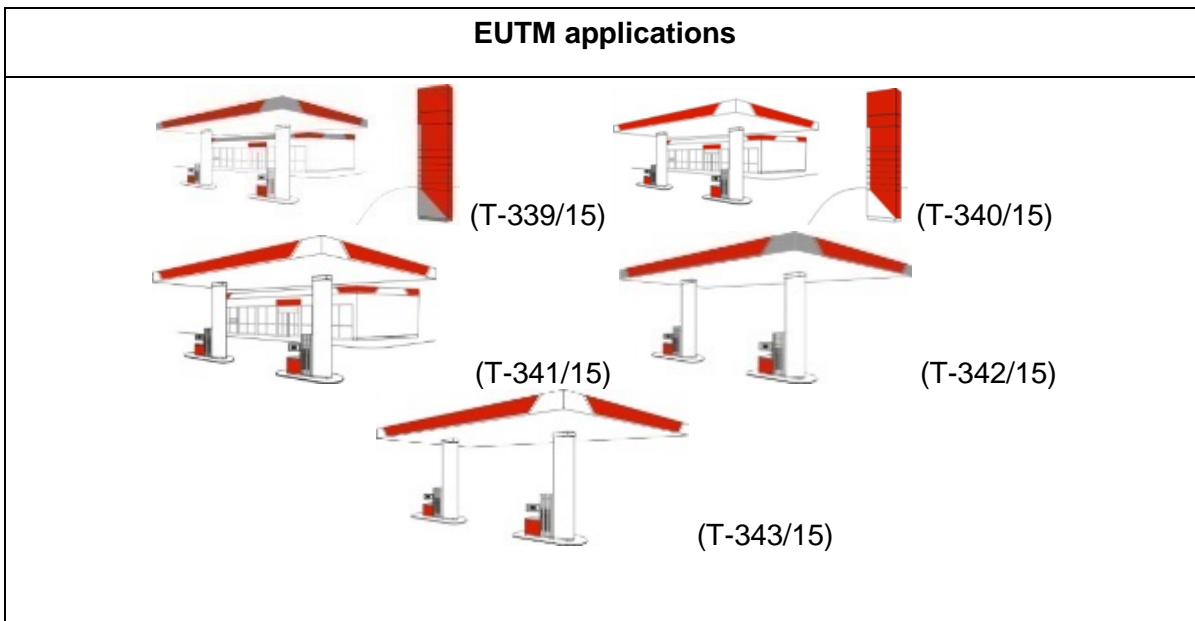

The EUTM applicant sought to register five three-dimensional trade marks depicted above for the goods and services in Classes 4, 35, 37, 39 and 43. The Office informed the EUTM applicant of the grounds for refusal of registration of the marks and rejected the applications for registration pursuant to Article 7(1)(b) EUTMR. The applicant filed appeals against the Office’s decisions. The Board of Appeal (BoA) found that the marks were devoid of any distinctive character for some goods and services but it appeared that the Office’s justification for the lack of distinctiveness of the marks applied for was not sufficient for all the goods and services at issue. The BoA annulled the Office’s decision and remitted the case for renewed assessment. The EUTM applicant filed an action before the General Court (GC) relying on three pleas in law: (i) infringement of Article 94 EUTMR, (ii) infringement of the principle of equal treatment and of the principle of sound administration and (iii) infringement of Article 7(1)(b) EUTMR. The Office argued that the action was not admissible because the decisions of the BoA annulled the decisions of the first instance, and the BoA did not rule on the distinctive character of the marks applied for and, consequently, the applicant was not adversely affected. The BoA justified its annulment decision on the following grounds. It considered that the respective mark applied for was devoid of any distinctive character, ‘in particular as regards fuel, retail sales of fuels, but also in relation to the typical services offered at service stations, such as the sale of beverage and magazine retailers, loyalty management programmes and food services’. However, it added that the Office’s justification for the lack of distinctiveness of the marks applied for was not sufficient for all the goods and services in question. Moreover, the BoA



considered that the application also included products and services which would not be part of the usual range of goods and services offered at petrol stations (aviation fuel, petroleum coke, xylenes and wholesale of fuel), and that the Office should have examined and substantiated in detail why the marks applied for could not fulfil the function of indicating the commercial origin of those goods and services (para. 41). The GC found that for those goods and services the BoA did not rule on the distinctive character of the marks applied for. Consequently, the BoA did not rule on that point in a negative way for the applicant (para. 43). For those goods and services the application was inadmissible (para. 44). However, for the goods and services that are typically offered in petrol stations, the GC considered that the BoA, in the reasoning behind its decision, did rule on the distinctiveness of the signs. This is because from the reasoning of the BoA's decisions it can be understood that the BoA had found that at least for some goods and services the justification of the refusal provided by the first instance was sufficient. However, the BoA did not reject the applicant's appeal with regard to those goods and services, because the BoA annulled the decisions of the first instance without making any distinction between the goods and services (paras 48, 49). The GC found that neither the operative part of the BoA decisions nor their reasoning allowed for a clear understanding as to which of the goods and services normally supplied at the petrol stations the BoA ruled on the distinctiveness of the applications (para. 50), and for which of them the reasoning of the first instance has been found to be sufficient (para. 51). The BoA did refer to the goods and services supplied at service stations, which might suggest that the lack of justification covered all those goods and services (para. 52). But it specifically mentioned only certain services and such reasoning does not make it possible to understand whether the insufficiency of justification concerns only these services or also other typical products or services offered at service stations (para. 53). The GC observed that there was a partial discrepancy between the reasoning of the BoA decisions and their operative parts, as well as a lack of clearness as to the BoA's position on distinctiveness of the signs (para. 54). Given that the contested decisions are not clear as to whether the BoA has ruled on the question of the distinctive character of the marks applied for for the goods and services other than those that are not part of the usual goods and services offered in service stations, the grounds of inadmissibility of the appeal relied on by the Office cannot be retained. The contested decisions must therefore be annulled in that they contain a discrepancy between their operative parts and their reasoning and that there is insufficient reasoning for those goods and services other than those that are not part of the usual goods and services used in service stations (paras 55-56).

♦[T-25/17](#); **PROTICURD / PROTIPLUS et al.**; Bernhard Rintisch v EUIPO; Judgment of 19 April 2018; EU:T:2018:195; Language of the case: EN. The international registration designating the European Union of the word mark **PROTICURD** was notified to the Office for registration for goods in Classes 5 and 29. An opposition based on the earlier German word marks **PROTI** and **PROTIPLUS** (Classes 29 and 32), as well as the German figurative mark 'ProtiPower (fig.)', was filed pursuant to Article 8(1)(b) EUTMR. The Opposition Division (OD) upheld the opposition and the IR holder appealed. The Board of Appeal (BoA) partially upheld the appeal and rejected the opposition for all the contested mark's goods in Class 5 (*pharmaceutical preparations; dietetic substances for medical purposes, dietetic preparations, dietary supplements, parapharmaceutical products, all for medical purposes*), and some of the goods in Class 29, namely milk powders and *milk beverages, with milk predominating*. The opponent filed an action before the General Court (GC) relying, inter alia, on the infringement of Article 8(1)(b) EUTMR. The GC upheld the plea in law based on the infringement of the duty to state reasons and annulled the BoA's decision. The case was referred to the BoA for a new ruling which annulled the OD's decision. The opponent filed an action before the GC relying on three pleas in law: (i) infringement of



Article 94 EUTMR, (ii) infringement of Article 47(2) EUTMR, and (iii) infringement of Article 8(1)(b) EUTMR. **On the alleged infringement of the obligation to state reasons.** The BoA provided a due statement of reasons as to whether proof of genuine use was provided for the earlier mark for goods in Class 29. It observed that those goods could fall within Class 29 only if they were added to a milk beverage or to a beverage with milk predominating before being marketed, but the evidence did not show that those goods were marketed in that form. Consequently, the BoA concluded that, for the purposes of the opposition proceedings, the earlier mark **PROTI** had to be deemed to have been registered for protein preparations in powder form for beverages supplemented with vitamins or minerals as well as with carbohydrates in Class 32 (paras 38-39).

♦[T-220/17](#); **100% Pfalz (fig.)**; *Pfalzmarkt für Obst und Gemüse eG v EUIPO*; Judgment of 26 April 2018; EU:T:2018:229; Language of the case: DE. The applicant sought to register the figurative mark ‘100% PFALZ’ as an EUTM for goods and services in Classes 31 (*fresh fruits and vegetables*) and 35 (*retail and wholesale services of fruits and vegetables*). The Office refused the registration of the mark according to Article 7(1)(b) and (c) EUTMR. An appeal was filed against the Office’s decision and the Board of Appeal (BoA) upheld the appeal, declaring that the application was descriptive and non-distinctive. The applicant appealed to the General Court (GC), relying on three pleas in law: (i) infringement of Article 7(1)(c) EUTMR, (ii) infringement of Article 7(1)(b) EUTMR and (iii) Article 94 EUTMR. **The duty to state reasons.** The BoA complied with its duty to state reasons. The BoA did not refer to all of the previous BoA decisions quoted by the applicant. However, it examined two decisions cited by the applicant and several earlier applications containing one of the elements of the application, ‘100 %’ (para. 14).

♦[T-193/17](#), [T-194/17](#) and [T-195/17](#) (joined cases); **DEVICE OF COMPONENT OF PROTHESIS (fig.)**; *CeramTec GmbH v EUIPO*; Judgment of 3 May 2018; EU:T:2018:248; Language of the case: EN. The EUTM proprietor was granted registration of three EUTMs for goods in Class 10. Applications for invalidity were filed against the three marks in response to two infringement proceedings, which the EUTM proprietor had brought on the basis of the contested marks before the Landgericht Stuttgart (Stuttgart District Court, Germany) and the Tribunal de Grand Instance de Paris (Paris Regional Court, France). The invalidity applicant, however, subsequently informed the Office that it had filed counterclaims for a declaration of invalidity of the contested marks in response to the infringement proceedings before the Tribunal de Grande Instance de Paris and that it was withdrawing its applications for a declaration of invalidity before the Office. The Cancellation Division (CD) closed the cases and ordered the invalidity applicant to pay the costs incurred by the EUTM proprietor in connection with the invalidity proceedings. The EUTM proprietor filed three actions against the decisions of the CD closing the cases, claiming in particular that the closure of the proceedings following the invalidity applicant’s withdrawal required its consent, that the withdrawal had occurred at an advanced stage of proceedings and that it had been deprived of the possibility of obtaining a positive decision on the validity of the contested marks. The Board of Appeal (BoA) dismissed the EUTM proprietor’s actions as being inadmissible, holding that the CD decisions had not adversely affected the EUTM proprietor insofar as the marks remained on the Office’s register and the invalidity applicant had been ordered to pay the costs incurred by the EUTM proprietor. The EUTM proprietor appealed before the General Court (GC) relying on two pleas in law: (i) infringement of Article 67 and 94 EUTMR and (ii) infringement of Article 94 and 107 EUTMR. **Insufficient statement of reasons.** The EUTM proprietor cannot criticise the BoA for having failed to state sufficient reasons for its contested decisions with regard to the legal consequences flowing from the absence of a final decision on the merits, since the theory associated with pursuing invalidity proceedings following the surrender of the contested mark arising from



case-law is not applicable in a case concerning invalidity proceedings (para. 42).

♦ [T-188/17](#); **Coil Liner**; *Bernard Krone Holding SE & Co. KG v EUIPO*; Judgment of 4 May 2018; EU:T:2018:253; Language of the case: DE. The applicant sought to register the word mark **Coil Liner** for the goods and services in Classes 12 and 35. The Office refused registration of the trade mark applied for pursuant to Article 7(1)(b) and (c) EUTMR for all the goods and services abovementioned. The applicant appealed against the decision and the Board of Appeal (BoA) partially annulled the Office's decision for the goods in Class 35 and dismissed the appeal for the goods in Class 12 as it found that the mark applied for was descriptive for those goods. The EUTM applicant appealed to the General Court (GC) relying on two pleas in law: (i) infringement of Article 7(1)(c) EUTMR and (ii) infringement of Article 7(1)(b) EUTMR. As the BoA considered that the relevant public was 'the English-speaking public of the Union' and examined the meaning of the term 'liner' in German, it vitiated the contested decision with a contradiction of reasons (para. 34). None of the sources mentioned in the contested decision allowed to establish that the verbal sign in question could designate, in English, the other goods and services in question (para. 37). The BoA did not sufficiently examine the meaning of the term 'liner' in English, as claimed by the applicant, and therefore did not assess the perception of the disputed sign by the relevant public as it itself defined it (para. 38). Regarding the term 'gigaliner', which would also be understood by the English-speaking public, this statement is not supported by any evidence and the only source mentioned in the contested decision in this respect is an article in German (para. 40). The statement that the relevant public is people whose mother tongue is not English but who have a good command of English, is not supported by any evidence and does not establish in any way that persons who are fluent in English would understand sources in German (para. 41).

♦ [T-222/14 RENV](#); **deluxe (fig.)**; *Deluxe Entertainment Services Group Inc v EUIPO*; Judgment of 4 July 2018; EU:T:2015:364; Language of the case: ES. The applicant sought to register the figurative mark 'deluxe' as an EUTM for goods and services in Classes 9, 35, 37, 39, 40, 41, 42 and 45. The Office refused to register the mark for all the goods and services on the grounds of Article 7(1)(b) and (c) EUTMR. The Board of Appeal (BoA) dismissed the applicant's appeal. It found that the mark was devoid of any distinctive character and that the claimed acquired distinctiveness of the mark through its use had not been proven. The applicant filed an action before the General Court (GC) relying on five pleas in law. The GC annulled the contested decision of the BoA on the grounds that the BoA neither carried out the specific assessment required in Article 7(1)(b) EUTMR nor justified its decision for each of the goods and services. The Office lodged an action before the Court of Justice of the European Union (CJ). The CJ annulled the GC's decision and remitted the case to the GC for further assessment. **Infringement of Article 94 and Article 7(1)(b) EUTMR.** The verbal element of the mark transmits the idea of 'superior quality' and also constitutes 'a direct reference to the concept of luxury'. This term, under both meanings, has a laudatory character and the public will immediately perceive it as a promotional formula that points out a positive characteristic of the goods (paras 46-47). 'Deluxe' constitutes a confirmation of a superior quality that belongs to the category of promotional tags, and being of 'superior quality' can be considered as a characteristic of all the goods and services involved. Therefore, the public will immediately perceive this as a laudatory term referring to the goods and services instead of an indication of their business origin (para. 50). Despite the distinctive character of the figurative element of the mark applied for, the relevant public will understand that mark, considered as a whole, in particular due to the size and central position of its word element, as a direct and immediate confirmation of the superior quality of the designated goods and services, and not as an indication of their commercial origin. The sign is therefore devoid of any distinctive



character (paras 57-59). The court confirms that all the goods and services designated in the application can be advertised as being of superior quality and that this is a pertinent characteristic for the assessment of the ground under Article 7(1)(b) EUTMR, on the basis of which they form a category sufficiently homogeneous to justify a common global motivation (paras 60-62). **Infringement of Article 7(1)(c) EUTMR.** Given that the BoA considered that the sign in question lacks distinctive character, it did not commit an error when it did not examine the ground based on Article (7)(1)(c) EUTMR (para. 78).

♦[T-581/17](#); **DEVICE OF FOUR CROSSING LINES (fig.) / DEVICE OF FOUR CROSSING LINES (fig.) et al.**; *Asics Corporation v EUIPO*; Judgment 16 October 2018; EU:T:2018:685; Language of the case: EN. The applicant sought to register the figurative mark 'DEVICE OF FOUR CROSSING LINES' as an EUTM for goods in Classes 18, 24 and 25. An opposition based on the earlier EU figurative mark 'DEVICE OF FOUR CROSSING LINES' (for goods in Class 18) and an earlier Spanish figurative mark (for goods in Class 25) was filed pursuant to Article 8(1)(b) and Article 8(5) EUTMR. The Opposition Division (OD) dismissed the opposition, so the opponent filed an appeal. The Board of Appeal (BoA) dismissed the appeal, finding that the signs gave an overall different impression. It added that, as the signs were purely figurative, no phonetic comparison was possible and that the conceptual comparison remained neutral. The opponent filed an action before the General Court (GC), relying on five pleas in law: (i) infringement of Article 95(1) EUTMR, as the BoA committed a manifest error in the assessment of the facts and an infringement of essential procedural requirements during the comparison of the signs, (ii) infringement of the obligation of the BoA to review the legality of the OD's decision, (iii) infringement of Article 94 EUTMR as the BoA infringed its obligation to state reasons, (iv) infringement of Article 8(1)(b) EUTMR, and (v) infringement of Article 8(5) EUTMR. **Scope of proceedings and statement of reasons.** The BoA did not disregard the existence of the earlier Spanish mark, but, in essence, considered that, for the purposes of their comparison with the contested mark, it was possible to disregard the slight differences between the two earlier marks (para. 20). Moreover, the applicant claimed the seniority of the earlier Spanish mark for the purposes of registration of the earlier EU trade mark, which demonstrates that the applicant itself considered that those marks were identical (para. 22) As the BoA did not overlook the existence of the earlier Spanish trade mark, a statement of reasons concerning the failure to take that earlier sign into account is not warranted (para. 31).

♦[T-63/17](#); **Bingo VIVA! Slots (fig.) / vive bingo (fig.)**; *Grupo Orenes, S.L. v EUIPO*; Judgment of 24 October 2018; EU:T:2018:716; Language of the case: ES. The applicant sought to register the figurative mark 'Bingo VIVA! Slots' as an EUTM for *online video game services related to free games* in Class 41. An opposition based on the earlier figurative EUTM 'vive bingo', registered for services in Classes 28, 35, 36, 38 and 41, was filed pursuant to Article 8(1)(b) EUTMR. The Opposition Division (OD) dismissed the opposition. The opponent filed an appeal. The Board of Appeal (BoA) dismissed the appeal. It found that the services were identical and the signs had a very low visual similarity and an average phonetical and conceptual similarity. It considered that given the nature of the services in question, the visual aspect should be favoured in the assessment and consequently, a likelihood of confusion (LOC) between the signs had to be excluded. The opponent filed an action with the General Court (GC), relying on two pleas in law: (i) infringement of Article 94 EUTMR and ii) infringement of Article 8(1)(b) EUTMR. The submission that the BoA should have carried out a comparison of the services different from that carried out by the first instance of the Office, which had been accepted by the opponent in the administrative proceedings, implies amending and enlarging the subject matter of the proceedings before the BoA. Consequently, the claim that the BoA failed to



fulfil its obligation to state reasons is rejected, since it is based on an inadmissible modification of the subject matter of the proceedings (paras 19-21).

♦[T-359/17](#); **ALDI / ALDO (fig.)**; *Aldo Supermarkets v EUIPO*; Judgment of 25 October 2018; EU:T:2018:720; Language of the case: EN. The applicant sought to register the word mark **ALDI** as an EUTM for, inter alia, services in Class 35. An opposition was filed pursuant to Article 8(1)(b) and Article 8(5) EUTMR, based on the earlier Bulgarian figurative mark 'ALDO', identified in colour in the opposition notice and attached to it in a separate document in colour, although this additional document did not indicate its origin. The Office found the opposition admissible and invited the opponent to substantiate the earlier right. During the substantiation period, the opponent submitted a black and white copy of the registration certificate of the Bulgarian mark and a translation of that document, including a translation of the colours of the earlier mark, into the language of proceedings. The Opposition Division (OD) partially upheld the opposition. However, the BoA rejected it as unsubstantiated. The opponent appealed to the General Court (GC), relying on four pleas in law: (i) infringement of Article 7 EUTMDR and of the principle of legal certainty, (ii) contradictory reasoning, (iii) infringement of the rights of the defence and of the principle of the right to be heard and (iv) infringement of Article 47(2) EUTMR and Article 10(3) and (4) EUTMDR. **On the first and second pleas.** (i) The legal requirements concerning the presentation of the facts, evidence and arguments and of the supporting documents are not conditions of admissibility of the opposition, but conditions relating to the examination of its substance (paras 39, 64). For the purposes of admissibility, it suffices that the notice of opposition includes a representation of the earlier mark, in colour if necessary, whatever its source, to enable clear identification of the earlier mark invoked. Those requirements are distinct from those applicable to proof of the existence, validity and scope of protection of the earlier mark (para. 43). The requirement to produce the registration certificate is not an end in itself, but is intended to ensure that the EUIPO has reliable proof of the existence, validity and scope of protection of an earlier trade mark on which an opposition is based (para. 37). The production of a copy of a registration certificate that is fully in line with the original from which it was copied does not satisfy the aim of identification, as in the notice of opposition, but that of demonstration of the existence, validity and scope of protection of the earlier mark as registered. The copy of the registration certificate should be identical in every respect to the original certificate, and therefore must show any colours claimed (paras 40, 44, 45, 54). In the Office's letter requesting the opponent to provide evidence of its earlier mark, it was expressly stated that the registration certificate or any equivalent official document submitted as evidence of the existence of the earlier right should include a representation of the mark as registered, that is to say, in colour if necessary (para. 47). The different variations of the representation of the earlier mark (in orange, blue and white, in black and white, and in red, black and white) did not satisfy the condition of accuracy and reliability inherent to Article 7 EUTMDR (para. 48). Furthermore, the possibility offered by the Office Guidelines to provide other documents to support a claim of a colour mark applies only to marks registered in those States in which the certificate does not make it possible to provide a representation of the registered mark in colour (para. 53) (ii) There was no contradictory reasoning: on the one hand, the BoA found that the opposition was admissible under Article 2 EUTMDR, as the notice of opposition contained a colour representation of the earlier mark, while, on the other, it concluded that the applicant had not provided proof of the earlier right, as it had not filed a copy of the registration certificate identical to the original, in colour, in accordance with Article 7 EUTMDR (para. 65).



♦[T-460/17](#); **DARSTELLUNG EINES GLEICHWINKLIGEN ACHTECKS**; *Carsten Bopp v EUIPO*; Judgment of 21 November 2018; EU:T:2018:816; Language of the case: DE

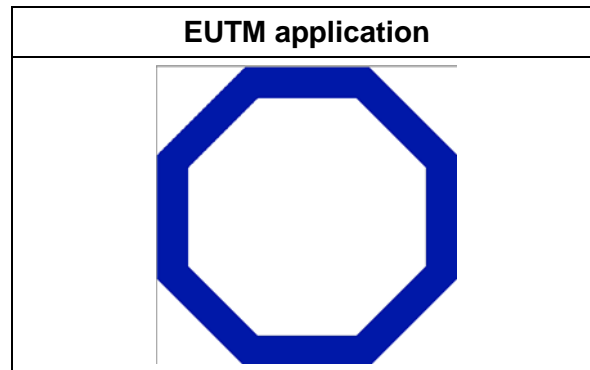

The applicant sought to register the figurative mark above claiming the colour 'blue' as an EUTM for the goods and services in Classes 16, 42 and 45. The examination proceedings were stayed until the final outcome on the registrability of the applicant's parallel EUTM application for a green octagonal frame. When the Court of Justice (C-653/15) dismissed the appellant's appeal regarding the latter, confirming that the parallel EUTM application lacked distinctive character, the Office gave the applicant the opportunity to submit observations on the judgment. The Office did not receive any observations. Irrespective of this fact, it refused the EUTM application referring to the ECJ judgment. The applicant appealed, claiming before the Boards of Appeal (BoA) that (i) it submitted observations that were not taken into account, (ii) it was never given the opportunity to submit observations on the claim that the EUTM application was not registrable in part of the EU and (iii) the EUTM application was distinctive. The BoA dismissed the appeal confirming non-distinctiveness of the mark. Taking into account the judgment regarding the green octagonal frame, the Office refused the EUTM application, and therefore it was up to the applicant to prove that the contested mark would be perceived as an indication of the origin. The applicant filed an action before the General Court (GC), relying on two pleas in law: (i) infringement of Article 7(1)(c) EUTMR and (ii) infringement of Article 94 EUTMR. **On the duty to state reasons.** The contested decision does not lack reasoning as to the assessment of the goods and services for which protection was sought. A general reasoning may be given for a homogenous group of goods. Since the reasoning that the sign is merely decorative applies to all goods and services, the group is homogenous (paras 55-57). The contested decision does not lack reasoning as to the registered marks quoted by the applicant, either. The BoA was not obliged to provide specific reasons in that regard (para. 67).

♦♦[T-372/17](#); **LV POWER ENERGY DRINK (fig.) / LV (fig.)**; *Louis Vuitton Malletier v EUIPO*; Judgment of 29 November 2018; EU:T:2018:851; Language of the case: EN. The applicant sought to register the figurative mark 'LV POWER ENERGY DRINK' as an EUTM for goods and services in Classes 32, 35 and 43. An invalidity application was filed for all the abovementioned goods and services pursuant to Article 60(1)(a) EUTMR in conjunction with Article 8(5) EUTMR, based on the earlier figurative mark 'LV'. The Cancellation Division (CD) dismissed the invalidity application. The invalidity applicant filed an appeal against the CD's decision and the Board of Appeal (BoA) dismissed the appeal. The invalidity applicant filed an action with the General Court (GC), relying on two pleas in law: (i) infringement of Article 8(5) EUTMR and (ii) infringement of the principle of legal certainty and infringement of Article 94 EUTMR. **Infringement of Article 94 EUTMR.** The CD's decision shows that based on documents provided by the invalidity applicant, the reputation



of the earlier mark in the EU was established by the Office in four decisions between 2002 and 2015, and was supported by several national decisions between 2007 and 2013. At least some of the decisions also show that this reputation was for goods identical to those in question (para. 49). Although the earlier decisions of the Office were duly relied on by the invalidity applicant, they were not examined or even specifically identified in the contested decision. The BoA merely stated that the Office was not bound by its previous decision-making practice (para. 41). The BoA should have explicitly stated its reasons for departing from the previous decisions on the reputation of the earlier mark, as the context in which it adopted the contested decision included reliance on those previous decisions. It is clear that the BoA did not show in any way that the mark no longer had a reputation, or that its reputation had become weaker since those decisions were handed down, or that the previous decisions were potentially unlawful (para. 52). The decision of the BoA was therefore adopted in breach of Article 94 EUTMR. It is not necessary to examine the alleged infringement of the principle of legal certainty (para. 53).

♦[T-373/17](#); **LV BET ZAKŁADY BUKMACHERSKIE (fig.) / LV (fig.)**; *Louis Vuitton Malletier v EUIPO*; Judgment of 29 November 2018; EU:T:2018:850; Language of the case: EN. The applicant sought to register the figurative mark ‘LV BET ZAKŁADY BUKMACHERSKIE’ as an EUTM for goods and services in Classes 28, 35 and 41. An opposition based on the earlier figurative mark ‘LV’ was filed for all the abovementioned goods and services pursuant to Article 8(1)(b) and Article 8(5) EUTMR. The Opposition Division (OD) upheld the opposition. It found that the signs had a low degree of visual similarity, that they had a low, average or very high degree of phonetic similarity, depending on the part of the relevant public taken into consideration, and that they were conceptually dissimilar. The OD also found that the reputation of the earlier mark was proven in the EU for a significant part of its goods in Classes 18 and 25 and that an association between the marks was possible. Lastly, it considered that the mark applied for was likely to take unfair advantage of the reputation and the distinctive character of the earlier mark. The applicant filed an appeal. The Board of Appeal (BoA) upheld the appeal, annulled the OD’s decision and rejected the opposition in its entirety. The opponent filed an action with the General Court (GC), relying on two pleas in law: (i) infringement of Article 8(5) EUTMR and (ii) infringement of the principle of legal certainty and infringement of Article 94 EUTMR. **Infringement of Article 94 EUTMR.** The OD’s decision shows that based on documents provided by the opponent, the reputation of the earlier mark in the EU was established by the Office in four decisions between 2002 and 2015, and was supported by several national decisions between 2007 and 2013. At least some of the decisions also show that this reputation was for goods identical to those in question (para. 48). Although the earlier decisions of the Office were duly relied on by the opponent, they were not examined or even specifically identified in the contested decision. The BoA merely stated that the Office was not bound by its previous decision-making practice (para. 40). The BoA should have explicitly stated its reasons for departing from the previous decisions on the reputation of the earlier mark, as the context in which it adopted the contested decision included reliance on those previous decisions. It is clear that the BoA did not show in any way that the mark no longer had a reputation, or that its reputation had become weaker since those decisions were handed down, or that the previous decisions were potentially unlawful (para. 51). The decision of the BoA was therefore adopted in breach of Article 94 EUTMR. It is not necessary to examine the alleged infringement of the principle of legal certainty (para. 52).

♦[T-471/17](#); **EDISON (fig.)**; *Edison SpA v EUIPO*; Judgment of 7 December 2018; EU:T:2018:887; Language of the case: IT. In 2003 the EUTM proprietor applied for the figurative mark ‘EDISON’ as an EUTM for all the goods covered by the general indications in Class 4. The mark was registered in 2013. In 2015, the EUTM proprietor requested the





Office to modify the previous list of goods by limiting it. The Office partly upheld the limitation request except for *electrical energy*, because no such product existed in the list of goods in Class 4 of the 8th Nice Classification, which is the applicable edition in this case. The EUTM proprietor appealed and the Board of Appeal (BoA) endorsed the Office's conclusion, stating that by accepting *electrical energy* the scope of protection of the sign would be unduly widened. The EUTM proprietor filed an action with the General Court (GC) relying on two pleas in law: (i) infringement of Article 57 EUTMR in conjunction with Article 111 EUTMR and (ii) infringement of Article 94 EUTMR. **Failure to state reasons.** The EUTM proprietor was given the opportunity to be heard on all points of fact and law on which the BoA based its decision. The continuity in terms of their functions between the different units of the Office enables the BoA to complement the Office's reasoning or dismiss the appeal on the basis of a slightly different reasoning than that used in the first instance decision (para. 62). The contested decision contains an explanation of the reasons which led to the dismissal of the limitation request, and which is sufficiently detailed to allow the EUTM proprietor to understand the reasoning of the BoA and the GC (para. 71).

### 2.3. *Ultra petita*

♦[T-424/16](#); **Footwear**; *Gifi Diffusion v EUIPO*; Judgment of 14 March 2018; EU:T:2018:136; Language of the case: EN. The RCD proprietor was granted the registration of a design as an RCD for goods in Class 02-04 of the Locarno Classification (*footwear*). An application for invalidity was filed pursuant to Article 52 CDR in conjunction with Article 25(1)(b) CDR and the invalidity applicant claimed lack of novelty by reason, inter alia, of prior disclosure of various earlier designs. It also claimed lack of individual character because the overall impression it produced was similar to that of designs D 1, D 18a, D 18b and D 19, as well as designs D 20-22. The Invalidity Division (ID) upheld the application for invalidity and declared the contested design invalid due to a lack of individual character in relation to the earlier Community design (D 1). The RCD proprietor appealed and the Board of Appeal (BoA) upheld the appeal stating that the application for invalidity needed to be re-examined 'in its entirety'. It nevertheless restricted its examination to a comparison between the contested design and designs D 1 to D 17, without expressing a view on designs D 18 to D 22. The invalidity applicant filed an action before the General Court (GC) relying on two pleas in law: (i) infringement of Article 6 CDR and (ii) infringement of Article 62 and Article 63(1) CDR. (i) The Office put forward two grounds: designs D 20 and D 22 were invoked at a later stage of the proceedings, and designs D 18a, D 18b and D 19 were not invoked with sufficient clarity and precision (para. 30). It is not possible, however, to give this additional statement of reasons for the first time before the Court (para. 34). Furthermore, even assuming that the BoA considered that some designs had been invoked late, it was required to give reasons for its decision in that regard (para. 38). Moreover, the application for a declaration of invalidity contained not only the indication and the reproduction of designs D 18a, D 18b and D 19 but also documents proving the existence of those earlier designs, in the form of screenshots and copies of journals. What is more, the invalidity applicant referred to them both in its observations and before the BoA (para. 39). (ii) The BoA was, in principle, required to examine the contested design in relation to every earlier design duly invoked. Furthermore, the BoA recalled that it was required to re-examine the invalidity application in its entirety. In the absence of any statement of reasons for designs D 18 to D 22, the BoA's decision lacks reasoning (paras 41-42). (iii) The BoA has exceeded the limits of its powers and it has gone beyond the facts, evidence and arguments provided by the parties, since the 'party concerned' had never invoked a ground for invalidity alleging the lack of individual character of the contested design in relation to designs D 2 to D 17, but, on the contrary, had



restricted that ground for invalidity to designs D 1 and D 18 to D 22 (para. 47). (iv) The ground for invalidity examined of its own motion by the BoA entailed the assessment of different legal criteria, concerning two separate grounds for invalidity. The BoA itself stated on several occasions that the [invalidity] applicant 'did not give any explanation as to why these clogs should produce the same overall impression as the contested [design]', without taking account of the fact that this absence of explanation was due precisely to the fact that the latter had not invoked that ground for invalidity (para. 48). (v) In the absence of any statement of reasons in the BoA's decision in relation to designs D 18 to D 22, the GC cannot substitute its own reasoning for that of the BoA nor carry out an assessment on which the BoA has not yet adopted a position (para. 51).

♦♦[T-652/17](#); **Eddy's Snackcompany / TEDDY et al.**; *Eddy's Snack Company GmbH v EUIPO*; Judgment of 19 September 2018; EU:T:2018:564; Language of the case: DE. The applicant sought to register the word mark **Eddy's Snackcompany** as an EUTM for goods in Classes 29 and 30. An opposition based on, inter alia, the earlier German word mark **TEDDY**, registered for goods in Class 30, was filed pursuant to Article 8(1)(b) EUTMR against registration of the EUTM application for the goods for which protection was sought in Class 30. The Opposition Division (OD) dismissed the opposition. It found that despite a certain visual and aural similarity between the signs, there was, because of the total difference between their meanings, no likelihood of confusion (LOC). The opponent filed an appeal. The Board of Appeal (BoA) upheld the appeal. It found that there was a LOC: the goods were in part dissimilar and in part similar to varying degrees, while the signs had at least an average degree of visual and aural similarity and, conceptually, did not differ to the point that it was easy for the target public to differentiate between them. The applicant appealed to the General Court (GC), relying on two pleas in law: (i) infringement of Article 8(1)(b) EUTMR and (ii) infringement of Article 95(1) EUTMR. **Infringement of Article 95(1) EUTMR**. Although the opposition was directed only against the goods for which protection was sought in Class 30, the BoA rejected the EUTM application also for the goods in Class 29, thus ruling *ultra petita* and unlawfully extending its decision to goods outside the scope of the opposition. Consequently, the second plea must be upheld (paras 21-24).

#### **2.4. Other issues**

♦♦[C-418/16 P](#); **mobile.de**; *mobile.de GmbH v EUIPO*; Judgment of 28 February 2018; EU:C:2018:128; Language of the case: DE. The EUTM proprietor was granted the registration of the EU word mark **mobile.de** and the figurative mark 'mobile.de' as EUTMs for goods and services in Classes 9, 16, 35, 38 and 42. Two applications for invalidity were filed pursuant to Article 60(1)(a) EUTMR, relying on the earlier Bulgarian figurative mark 'mobile' covering services, inter alia, in Classes 35 and 42. The Cancellation Division (CD) dismissed both applications, on the ground that proof of use of the earlier mark was not provided. The CD's decisions were appealed and the Board of Appeal (BoA) found proof of genuine use of the earlier Bulgarian mark, but only for *advertising services for motor vehicles* in Class 35 and upheld the appeal. Since the CD had not examined likelihood of confusion, the BoA referred the case to the CD for examination. The EUTM proprietor filed two actions against the BoA's decisions before the General Court (GC), which dismissed both. The EUTM proprietor filed an appeal before the Court of Justice of the European Union (CJ). **On the referral of the case to the CD in its entirety**. In virtue of the principle of legal certainty and the definitive nature of its decisions, the CD cannot examine evidence of genuine use of the earlier national trade mark for the services for which the BoA found that evidence had not been adduced, unless the invalidity applicant challenges it by



bringing an action before the GC (para. 107). In the context of the remittal procedure, and since the BoA found that proof of genuine use of the earlier national mark had not been adduced by its proprietor for certain services, the CD's decisions must be regarded as having definitively rejected the applications for a declaration of invalidity as regards those services (para. 104). Therefore, the CD, in order to examine likelihood of confusion, can only take into account the services for which the BoA ruled that proof of use was submitted. **Assessment on the bad faith of the invalidity applicant.** The question on proof of use had to be settled before a decision is taken on the application for a declaration of invalidity and, is, therefore, in that sense, a 'preliminary issue' (para. 88). The GC was correct in holding that the BoA was entitled to refer the examination of the applications for declarations of invalidity back to that CD in order for it to rule on the inadmissibility of those applications due to the alleged bad faith of the invalidity applicant. The BoA is under no obligation to exercise the powers of the department which adopted the contested decision, having a wide discretion in that regard (paras 89 and 90).

♦[T-193/17](#), [T-194/17](#) and [T-195/17](#) (joined cases); **DEVICE OF COMPONENT OF PROTHESIS (fig.)**; *CeramTec GmbH v EUIPO*; Judgment of 3 May 2018; EU:T:2018:248; Language of the case: EN. The EUTM proprietor was granted registration of three EUTMs for goods in Class 10. Applications for invalidity were filed against the three marks in response to two infringement proceedings, which the EUTM proprietor had brought on the basis of the contested marks before the Landgericht Stuttgart (Germany) and the Tribunal de Grand Instance de Paris (Regional Court, France). The invalidity applicant, however, subsequently informed the Office that it had filed counterclaims for a declaration of invalidity of the contested marks in response to the infringement proceedings before the Tribunal de Grande Instance de Paris and that it was withdrawing its applications for a declaration of invalidity before the Office. The Cancellation Division (CD) closed the cases and ordered the invalidity applicant to pay the costs incurred by the EUTM proprietor in connection with the invalidity proceedings. The EUTM proprietor filed three actions against the decisions of the CD closing the cases, claiming in particular that the closure of the proceedings following the invalidity applicant's withdrawal required its consent, that the withdrawal had occurred at an advanced stage of proceedings and that it had been deprived of the possibility of obtaining a positive decision on the validity of the contested marks. The Board of Appeal (BoA) dismissed the EUTM proprietor's actions as being inadmissible, holding that the CD decisions had not adversely affected the EUTM proprietor insofar as the marks remained on the Office's register and the invalidity applicant had been ordered to pay the costs incurred by the EUTM proprietor. The EUTM proprietor appealed before the General Court (GC) relying on two pleas in law: (i) infringement of Article 67 and 94 EUTMR and (ii) infringement of Article 94 and 107 EUTMR. **Concept of a decision adversely affecting a party.** The concept of a decision adversely affecting a party cannot extend to considering the impacts of the absence of a final decision on the merits, which, having the authority of res judicata, would prevent the filing of a new application for a declaration of invalidity either before the Office or before the national courts. The case-law accepting the theory of the continuation of invalidity proceedings following a surrender of the contested mark cannot be applied to the present case, given that the effects of a surrender and those of a declaration of invalidity are not the same. Whereas an EU trade mark that has been surrendered ceases to have effects only as from the registration of that surrender, an EU trade mark that has been declared invalid is deemed not to have had any effects, as from the outset (paras 26-28). In the present case, had the EUTM proprietor been successful in having the applications for declarations of invalidity dismissed, there would have been no legal consequence for the status of the contested marks, as they would have remained on the Office's register as from the date of their registration (para. 29). If the interest which an EUTM proprietor claims concerns a future legal situation, the EUTM proprietor must



demonstrate that the prejudice to that future situation is already certain. Therefore, an EUTM proprietor cannot rely on future and uncertain situations to justify its interest in applying for annulment of the contested act (para. 31). The annulment of the decisions of the CD would not necessarily have led to a favourable decision being made on the merits of the validity of the contested marks. Consequently, the interest on which the EUTM proprietor seeks to rely is future and uncertain (para. 32). The question as to whether a decision adversely affects a party must be evaluated with respect to the instant proceedings and not in comparison with, or in conjunction with, other proceedings. Consequently, the existence of other proceedings before EU trade mark courts has no bearing on the conditions for the admissibility of the action before the BoA (para. 33). **Interpretation of the concept of 'principles of procedural law generally recognised in Member States'**. The provision in Article 107 EUTMR that in the absence of procedural provisions in the EUTM regulations, the EUIPO is to take into account the principles of procedural law generally recognised in Member States, does not apply in the present case where there are procedural provisions covering the matter, such as Article 109(4) EUTMR which explicitly deals with the consequences of a withdrawal of an application for a declaration of invalidity. That Article provides that the party who terminates proceedings by withdrawing the application for a declaration of invalidity is to pay the fees and the costs incurred by the other party. The logical reason for the existence of that provision can only be that the legislature wanted to confer on an applicant for a declaration of invalidity the right unilaterally to withdraw its application (paras 50-51). It follows that the issue raised by the EUTM proprietor's arguments is covered by the applicable EUTM procedural provisions. Consequently Article 107 EUTMR does not apply in the present case (para. 57). According to Article 63 EUTMR an application for a declaration of invalidity based on an absolute ground for invalidity does not require the applicant to show an interest in bringing proceedings insofar as the aim of the absolute grounds for refusal of registration is to protect the public interest underlying them. Consequently, there can be no question of an 'abuse of rights' on the part of the applicant for a declaration of invalidity (para. 60).

♦ [T-577/15](#); **SHERPA**; *Xabier Uribe-Etxebarria Jiménez v EUIPO*; Judgment of 29 May 2018; EU:T:2018:305; Language of the case: ES. The EUTM proprietor was granted registration of the word mark **SHERPA** as an EUTM for, inter alia, goods and services in Classes 9 and 42. An invalidity application was filed pursuant to Article 60(1)(a) EUTMR in conjunction with Article 8(1)(a) and (b) EUTMR, based on the earlier Spanish word mark **SHERPA** for *systems for the treatment of information and especially supervisory and control systems* in Class 9. Upon the EUTM proprietor's request, the invalidity applicant provided a series of documents as proof of use of its earlier mark. The EUTM proprietor then amended his list of goods in Class 9, introducing at the end of the list the limitation *with the express exclusion of supervisory and control systems and of systems for the treatment of information intended for supervision and control*. The Cancellation Division (CD) partly upheld the application for invalidity insofar as the evidence provided by the invalidity applicant proved use of the earlier mark in relation to *systems for the treatment of information and supervisory and control systems for industrial processes*. The EUTM proprietor filed an appeal against the CD decision and subsequently submitted two written statements setting out the appeal grounds — an initial one and a later one bearing the title 'supplementary brief' ('escrito complementario'). The Board of Appeal (BoA) dismissed the EUTM proprietor's appeal. It considered that neither party had expressed its disagreement with the CD's assessment of the evidence of use of the earlier mark. It consequently limited its examination to analysis of the application of Article 60(1)(a) EUTMR in conjunction with Article 8(1)(a) and (b) EUTMR. The BoA found that there was a likelihood of confusion for all the goods and services for which protection was sought in Classes 9 and 42, as the signs were identical and the goods and services either identical or similar. The EUTM



proprietor appealed to the General Court (GC), relying on three pleas in law: (i) infringement of Article 70(1), 71(1) and 95(1) EUTMR, (ii) infringement of Article 64(2) EUTMR in conjunction with Article 47(2) and (3) EUTMR and with Article 22 EUTMDR and (iii) infringement of Article 8(1)(a) and (b) EUTMR. **BoA's obligation to examine the evidence of use of the earlier mark at the request of the EUTM proprietor.** In the first brief with the appeal grounds before the BoA, the EUTM proprietor expressed his agreement with the CD's assessment of the evidence of use, while in his 'supplementary brief', meant to further develop the arguments of the earlier brief, he questioned that assessment. Confronted with two mutually exclusive passages, the BoA would be replacing the EUTM proprietor if it were to choose between his two contradictory positions and determine, by deduction, the grounds on which, in its opinion, the claim was based. It is the appellant who has to determine the framework of the controversy, formulating his requests and arguments in a precise and coherent manner so that the BoA understands why the appellant requests that the BoA annul or modify a decision. The documents provided by the EUTM proprietor did not meet this requirement at the time when they were submitted (paras 35-39). **BoA's obligation to examine the evidence of use of the earlier mark ex officio.** When the question of the actual use of the earlier mark has not been specifically raised before the BoA, that question does not constitute a point of law that must necessarily be examined by the BoA in order to settle the dispute (para. 46). The functional continuity between the Office's bodies and the devolutive effect of the appeal before the Board of Appeal does not have the consequence that the BoA must automatically rule on the use of the earlier trade mark when the appellant has not expressly raised such a question (para. 47).

♦ [T-297/17](#); **WE KNOW ABRASIVES**; *VSM.Vereinigte Schmirgel- und Maschinen-Fabriken AG v EUIPO*; Judgment of 24 April 2018; EU:T:2018:217; Language of the case: DE. The applicant sought to register the word mark **WE KNOW ABRASIVES** as an EUTM for goods and services in Classes 3, 7 and 35. The Office partially refused the registration of the EUTM application pursuant to Article 7(1)(b) EUTMR regarding the goods in Classes 3 and 7 and some services in Class 35 due to a lack of distinctiveness. For the remaining services in Class 35 (*advertising; business management; office functions; wholesaling in the fields of sanding machines, abrasive preparations, tools and goods of common metal for building; business administration*) no objection had been raised. The applicant appealed and the Board of Appeal (BoA) dismissed the appeal, insofar as it found that the slogan was non-distinctive, as the sign conveys an advertising statement. The applicant filed an action before the General Court (GC) relying on two pleas in law: (i) infringement of Article 7(1)(b) EUTMR and (ii) infringement of Article 66 and 67 EUTMR and Article 70(1) EUTMR. **Relevant public.** The relevant public is the English-speaking general public or professionals, since the mark is composed of three English words (para. 36). **Meaning of the sign and lack of distinctiveness.** The expression **WE KNOW ABRASIVES** is a word sequence that is formed from common English words (para. 39). The semantic content of the word mark (and each one of the words) is clear and precise (para. 40). Given the close connection between the sign and the goods and services concerned, as well as the ordinary character of the sign, the relevant public will immediately perceive the word mark, without further specific analytical or interpretative reflection, as a laudatory or promotional reference to the high quality and usefulness of the goods and services concerned (knowledge regarding abrasive products) and not as an indication of their commercial origin (para. 46). The word combination does not present, at a grammatical or syntactical level, any perceptible difference from the construction of an expression intended to convey the same message (para. 51). The syntactic variation is not such as to confer on the sign an unusual or ambiguous character (para. 50). The omission of the preposition which should, under the rules of English syntax, connect the verb with the object will not prevent the



relevant public from grasping the meaning of the expression (para. 52). The adduced distinctiveness acquired by use of the mark **VSM — WE KNOW ABRASIVES** should have been based on the ground of Article 7(3) EUTMR, and, in any event, the signs are different due to the additional word element 'VSM' (paras 58-59). (ii) The BoA has exceeded its limits of jurisdiction by deciding to refuse to register services in Class 35 which had not been refused by the Operations Department (OD) (para. 21). The applicant brought an appeal before the BoA against the OD's decision insofar as it refused all the goods and services except for some services in Class 35. The contested decision had to be annulled without any need to decide whether there had been an infringement of the right to be heard, as the BoA could only decide on the goods and services that had in fact been refused by the EUIPO (paras 19-20).

♦[T-817/16](#); **OV (fig.) / V (fig.)**; *Vans, Inc. v EUIPO*; Judgment of 6 December 2018; EU:T:2018:880; Language of the case: DE. The applicant sought to register the figurative mark 'V' as an EUTM for goods and services in Classes 18 and 25. An opposition based on the earlier figurative mark 'V', registered for goods and services in Classes 18 and 25, was filed pursuant to Article 8(1)(b) EUTMR. The existence of the earlier mark being an international registration was shown by an excerpt from the EUIPO's TMview database. The Opposition Division (OD) partially upheld the opposition. The applicant appealed and, in its observations, the opponent filed a cross-appeal. The Board of Appeal (BoA) dismissed the appeal in its entirety and upheld the cross-appeal partially. The applicant filed an action before the General Court (GC), relying on three pleas in law: (i) infringement of Article 7(2) and (4) and Article 8(1) and (7) EUTMDR, (ii) infringement of Article 8(1)(b) EUTMR and (iii) infringement of Article 68(1), first sentence, Article 70(2) and Article 94(1) EUTMR and of the principle of prohibition of *reformatio in peius* and of the right to be heard. **Cross-appeal.** The opponent was entitled, in its response to the applicant, to seek a decision annulling or altering the contested OD decision on a point not raised in the appeal before the BoA without being required to comply with the deadline and pay the fee provided in Article 68(1) EUTMR (para. 149). **Reformatio in peius.** Even if it were assumed that the prohibition of *reformatio in peius* can be invoked in relation to decisions of the Office's BoA, the argument that the BoA infringed that prohibition is unfounded since, when it upheld the opponent's request that the EUTM application also be rejected for *card cases*, the BoA simply allowed the opponent's cross-appeal submitted on the basis of Article 68(2) EUTMR and Article 8(3) of the Rules of Procedure of the Boards of Appeal (para. 156). Since none of the pleas raised by the applicant in support of its claims for annulment or alteration are well founded, the action must be dismissed in its entirety (para. 167). See also parallel case T-848/16.

♦[T-830/16](#); **PLOMBIR**; *Monolith Frost GmbH v EUIPO*; Judgment of 13 December 2018; EU:T:2018:941; Language of the case: DE. Pursuant to Article 59(1)(a) EUTMR and Article 7(1)(c) EUTMR an application for declaration of partial invalidity was filed against the word mark **PLOMBIR** as far as it was registered for goods in Classes 29 (*compotes, eggs, milk and milk products*) and 30 (*coffee, cocoa, ices*). The Cancellation Division (CD) granted the application for a declaration of invalidity for *milk and milk products* in Class 29 and *ices* in Class 30 since it held **PLOMBIR** as being descriptive. The intervener (cancellation applicant) filed an appeal. The Board of Appeal (BoA) annulled CD's decision. It found that the applicant had not shown that the Russian word is understood in the European Union, and in particular not in Germany. The applicant filed an action before the General Court (GC), relying on three pleas in law: (i) infringement of Article 7(1)(c) EUTMR, (ii) infringement of the principle of *ex officio* examination of the facts provided for in Article 95(1) EUTMR and (iii) infringement of the obligation to state reasons provided for in Article 94 EUTMR. The BoA infringed Article 95(1) EUTMR in that it could not exclude



nationals of the Baltic States from the definition of the relevant public on the sole ground of an absence of concrete evidence as to the understanding of Russian in those countries, without first deciding whether it was known that Russian was frequently understood by that population (para. 35). The BoA committed an error of assessment in determining the relevant public and a breach of Article 7(2) EUTMR, since the relevant public in relation to which the absolute ground for refusal had to be assessed was a Russian-speaking public, including the general public of the European Union who understand or speak Russian, and reside in Germany and the Baltic States (para. 60). In particular it was held sufficient that only 3 per cent of Germans understand Russian. Insofar as the term ‘plombir’ constitutes the faithful transliteration of the term ‘Пломбир’ into letters of the Latin alphabet known by the relevant Russian-speaking consumer of the European Union, its descriptive meaning is likely to be immediately and directly understood by that consumer (para. 75). As a result, there is no need to consider the third plea (para. 77).

### 3. *General principles of European Union Law*

♦[T-272/17](#); **Dating Bracelet (fig.)**; *Webgarden Szolgáltató és Kereskedelmi Kft v EUIPO*; Judgment of 20 March 2018; EU:T:2018:158; Language of the case: HU. The applicant sought to register the figurative mark ‘Dating Bracelet’ as an EUTM for goods and services in Classes 9, 41, 42 and 45. The Office refused the registration of the EUTM application pursuant to Article 7(1)(b) and (c) EUTMR. The EUTM applicant appealed and the Board of Appeal dismissed the appeal. It found that the mark was descriptive and non-distinctive. The EUTM applicant filed an action before the General Court (GC) relying on three pleas in law: (i) infringement of Article 4 EUTMR, (ii) infringement of Article 7(1)(b) and (c) EUTMR and (iii) infringement of the principles of equal treatment and legal certainty. **Principles of equal treatment and legal certainty.** The principle of equal treatment has to be reconciled with the principle of legality. Each trade mark application must be subject of a full assessment on its own merits and not on the basis of the Office’s previous decision-making practice (paras 71 and 73). The principle of legal certainty has also not been breached (para. 74).

♦[T-34/17](#); **SKYLEADER (fig.)**; *Skyleader a.s v EUIPO*; Judgment of 4 May 2018; EU:T:2018:256; Language of the case: EN. The applicant registered the figurative mark ‘SKYLEADER’ as an EUTM for goods in Classes 12 and 14. An application for revocation was filed pursuant to Article 58 EUTMR. The Cancellation Division (CD) set the applicant a time limit of 3 months to submit proof of genuine use of the mark. Within this time limit, the applicant submitted a two-page fax in which it listed, via annexes, proof of genuine use of the mark that was to be sent to the Office by courier. The listed documents were sent by mail within the time limit but the Office received them after the time limit. The CD informed the parties that the proof of use would not be taken into account since it was received outside the time limit set, and it upheld the application for revocation. The applicant appealed and the Board of Appeal (BoA) dismissed the appeal, as it found that the original documents containing the proof of use were received outside the time limit set. Moreover, the applicant did not take up the opportunity it was given of requesting an extension of the time limit or the continuation of proceedings, or of filing a request for *restitutio in integrum*. The applicant filed an action before the General Court (GC) relying on two pleas in law: (i) infringement of Article 19(1) EUTMDR in conjunction with Article 95(2) EUTMR, and (ii) infringement of the principle of sound administration. **Infringement of the principle of sound administration.** There is no provision requiring the Office to inform a party of the procedures available to it, nor is it incumbent on it to advise that party to pursue any particular legal remedy. In any event, information for the parties is contained in the



Guidelines for Examination in the Office, particularly in the event of expiry of a time limit. Therefore, the Office had no obligation of informing the applicant of the means for rectifying the late submission of proof of use (para. 43).

♦[T-638/16](#); **DARSTELLUNG EINES SCHUHES (fig.) / BALKENDARSTELLUNG AUF EINEM SCHUH (POSITIONSMARKE) et al.**; *Deichmann SE v EUIPO*; Judgment of 6 December 2018; EU:T:2018:883; Language of the case: DE

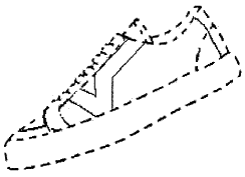
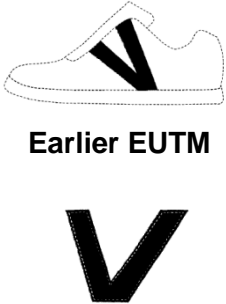
EUTM application	Earlier trade marks
	 <p data-bbox="959 757 1142 786">Earlier EUTM</p> <p data-bbox="847 949 1254 978">Earlier IR designating the EU</p>

The applicant sought to register the figurative mark above as an EUTM for *clothing, footwear, headgear; belts, gloves* in Class 25. An opposition based on the earlier position mark (EUTM) above, registered for *footwear* in Class 25, and on the earlier figurative mark above, registered for *clothing, footwear, headgear* (international registration (IR) designating the EU), was filed pursuant to Article 8(1)(b) EUTMR. The Opposition Division (OD) dismissed the opposition. The opponent filed an appeal. The Board of Appeal (BoA) dismissed the appeal. It found that the visual dissimilarities between the mark applied for and the earlier EUTM precluded any likelihood of confusion (LOC) between them. In addition, the extract in German from the CTM-Online (now eSearch Plus) database and the mention in the opposition form of the IR's goods did not constitute proof of the existence, validity and extent of protection of the mark. The opponent appealed to the General Court (GC), relying on two pleas in law: (i) infringement of Article 8(1)(b) EUTMR concerning the earlier EUTM; and (ii) infringement of Article 7(2) EUTMDR and Articles 8(1), (2) and (7) EUTMDR, of Article 189 EUTMR and of the principles of the protection of legitimate expectations and legal certainty and the prohibition of non-retroactivity concerning the earlier IR. **Second plea (concerning the earlier IR). Proof of the earlier IR designating the EU.** It follows from Article 7(2) EUTMDR, which is applicable to IRs designating the EU in accordance with Article 182 EUTMR, that the opponent must prove the filing or registration of the earlier mark, where the opposition is based on a mark other than an EUTM. The need to provide such evidence therefore also applies to IRs designating the EU, which are not EUTMs (para. 92). Excerpts from the Office's CTM-Online database do not constitute proof of the protection of an IR designating the EU, since the Office, which is not the competent authority for the registration of international registrations, is not the administration with which the trade mark application was lodged (para. 102-103). **The principle of the protection of legitimate expectations.** The Office's examination guidelines are not binding for the interpretation of EU law (para. 118). Moreover, a reference in such guidelines to 'Office practice' does not bind the BoA, whose members are independent and not bound by any instruction pursuant to Article 166(7) EUTMR (para. 119). The protection of legitimate expectations requires in any case that the assurances given comply with the applicable provisions. Even assuming that the Office's





examination guidelines relied on by the applicant could constitute precise, unconditional and consistent assurances from authoritative and reliable sources that extracts from the CTM-Online database would be accepted by the BoA as evidence of the earlier IR, such assurances breach the provisions of the EUTMR (para. 120). The applicant's argument that the Office infringed the principles of the protection of legitimate expectations and legal certainty and the prohibition on retroactivity is therefore unfounded and the second plea must also be dismissed. The action of the applicant must therefore be dismissed in its entirety (paras 127-128).

♦[T-222/14 RENV](#); **deluxe (fig.)**; *Deluxe Entertainment Services Group Inc v EUIPO*; Judgment of 4 July 2018; EU:T:2015:364; Language of the case: ES. The applicant sought to register the figurative mark 'deluxe' as an EUTM for goods and services in Classes 9, 35, 37, 39, 40, 41, 42 and 45. The EUIPO refused to register the mark for all the goods and services on the grounds of Article 7(1)(b) and (c) EUTMR. The Board of Appeal (BoA) dismissed the applicant's appeal. It found that the mark was devoid of any distinctive character and that the claimed acquired distinctiveness of the mark through its use had not been proven. The applicant filed an action before the General Court (GC) relying on five pleas in law. The GC annulled the contested decision of the BoA on the grounds that the BoA neither carried out the specific assessment required in Article 7(1)(b) EUTMR nor justified its decision for each of the goods and services. The Office lodged an action before the Court of Justice of the European Union (CJ). The CJ annulled the GC's decision and remitted the case to the GC for further assessment. **Infringement of the principles of the protection of legitimate expectations, acquired rights and legality of EU acts.** Regarding previous marks of the applicant which were allegedly accepted for registration by the Office, the court refers to its previous statement that the mark currently applied for, in relation to the goods and services at issue, incurred in one of the absolute grounds of refusal set out in Article 7(1) EUTMR. In any case, the applicant has not established that the Office infringed these principles when it refused the registration of the mark applied for. As to the alleged existence of national registrations, the court recalls that the EU trade mark regime is an autonomous system with its own set of objectives and rules peculiar to it (paras 105-108).

♦[T-488/17](#); **Dry Zone**; *Ghost — Corporate Management SA v EUIPO*; Judgment of 20 September 2018; EU:T:2018:571; Language of the case: PT. The applicant sought to register the word mark **Dry Zone** as an EUTM for goods in Classes 3, 5, 10 and 16. The EUIPO partially refused the trade mark applied for on the grounds that it did not comply with the provisions of Article 7(1)(b) and (c) and Article 7(2) EUTMR. The applicant filed an appeal. The Board of Appeal (BoA) dismissed the appeal. It found that the appeal was inadmissible due to the fact that it was lodged after the time limit laid down in Article 68 EUTMR. The applicant brought an action before the General Court (GC), relying on three pleas in law: (i) infringement of Article 68 EUTMR and Article 69 EUTMR, (ii) infringement of the principle of proportionality and (iii) infringement of the principles of legitimate expectations and legal certainty. **As regards the alleged infringement of Article 68 EUTMR.** Since the appeal was received by the Office on 4 April 2017, it was lodged after the expiry, on 3 April 2017, of the two-month period laid down in Article 68 EUTMR (para. 35). The applicant did not provide proof, which was incumbent on it, that the delivery time of the letter was the decisive cause of its failure to meet the time limit, in the sense that it was an event of an inevitable nature against which it could not have protected itself. It follows from the above considerations that the existence of a case of force majeure or exceptional circumstances has not been established (paras 46-47). **On the allegation of infringement of the principle of proportionality.** The applicant did not invoke any argument specifically related to this principle (para. 48). (iii) Article 68 EUTMR must be



interpreted as meaning that the date to be taken into account for compliance with the time limit to file an appeal is not the date on which the appeal was sent, but the date on which it was received by the Office. **On the alleged infringement of the principles of legitimate expectations and legal certainty.** The applicant cannot rely on the principle of protection of legitimate expectations in order to seek the annulment of the contested decision (paras 54-55). It is the principle of legal certainty itself which underlies the BoA's interpretation of Article 68 EUTMR. It follows that the applicant cannot rely on this principle to challenge the interpretation (para. 56).

♦[T-533/17](#); **nuuna (fig.) / NANU et al.**; *Next design + produktion GmbH v EUIPO*; Judgment of 18 October 2018; EU:T:2018:698; Language of the case: DE. The applicant sought to register the figurative mark 'nuuna' as an EUTM for goods in Class 16. An opposition was filed pursuant to Article 8(1)(b) EUTMR, that the opponent based on the earlier word marks **NANU-NANA** and **NANU**, both registered for goods in Class 16. The Opposition Division (OD) dismissed the opposition, so the opponent filed an appeal. The Board of Appeal (BoA) upheld the appeal, finding that the conflicting goods were identical or at least highly similar and that the signs had a low degree of visual similarity and an average degree of phonetic similarity. It also found that the earlier marks had an average distinctive character and concluded that there was a likelihood of confusion (LOC.) The applicant filed an action before the General Court (GC), relying on three pleas in law: (i) infringement of Article 8(1)(b) EUTMR, (ii) infringement of Article 1(1) EUTMR and the principle of autonomy and (iii) infringement of the principles of legal certainty, legality and good administration. **Definition of an EUTM and the principles of autonomy, legal certainty, legality and good administration.** Even if the BoA had to render its decision on the basis of the EUTMR, it must also take into account the interpretation of that regulation by the GC, including the judgment of 23 September 2014 (Nuna, T-195/12, EU:T:2014:804). The BoA did not infringe Article 1(1) EUTMR or the principles of autonomy and independence of the EUTM or those of legal certainty, legality and good administration, but instead provided a detailed reasoning leading to its conclusion of LOC. The action must be rejected in its entirety (paras 115-118).

---

## II. ABSOLUTE GROUNDS FOR REFUSAL/INVALIDITY

### A. Article 7(1)(a), 59(1)(a) EUTMR — Signs which do not conform the requirements of Article 4 EUTMR

[No entry]



**B. Article 7(1)(b), (c) and (d), 59(1)(a) EUTMR — Non-distinctive and descriptive trade marks, customary signs and indications**

**1. Outcome: Non-distinctive (Article 7(1)(b) EUTMR)**

**T-250/17; avanti (fig.); Avanti v EUIPO**; Judgment of 23 January 2018; EU:T:2018:24; Language of the case: DE



The applicant sought to register the figurative EUTM above for goods and services in Classes 9, 35, 41 and 42. The Office refused the registration of the EUTM application pursuant to Article 7(1)(b) and (c) EUTMR. The Board of Appeal (BoA) dismissed the applicant’s appeal. It found that the EUTM application would be perceived as a laudatory indication devoid of distinctive character for the goods and services at issue. The applicant filed an action before the General Court (GC) relying on a single plea in law: infringement of Article 7(1)(b) EUTMR. The GC dismissed the action. **Relevant public.** The relevant public is composed of professionals and employers displaying a high degree of attention (para. 19). **Perception of the sign.** The element between ‘a’ and ‘anti’ will be perceived by the relevant Italian and German-speaking public as the letter ‘v’. The EUTM application as a whole will be perceived, immediately and without further thought, as a representation of the word ‘avanti’ (paras 20-23). **Lack of distinctive character.** The term ‘avanti’ will be seen as a slogan stating that the goods and services provided will enable the customer to move forward and make progress. The stylised letter ‘v’ evokes the symbol ‘OK’, conveying the positive idea that the goods and services are ‘OK’ (i.e. tested, approved or verified). Therefore, the EUTM application as a whole will be perceived as a promotional and incentive message and not as an indication of commercial origin (paras 24-25).

**T-843/16; Foto Paradies; dm-drogerie markt GmbH & Co. KG v EUIPO**; Judgment of 28 February 2018; EU:T:2018:102; Language of the case: DE. The EUTM proprietor was granted registration of the word mark **Foto Paradies** for, inter alia, goods and services in Classes 1, 9, 16, 20, 38, 40 and 42. The intervener filed an application for a declaration of invalidity pursuant to Article 59(1)(a) EUTMR, read in conjunction with Article 7(1)(b) and (c) EUTMR. The Cancellation Division (CD) rejected the application and the intervener filed a notice of appeal against the CD’s decision. The Board of Appeal (BoA) annulled the CD’s decision and declared the contested mark invalid for the contested goods and services. The EUTM applicant filed an action before the General Court (GC) relying on a single plea in law: infringement of Article 59(1)(a) EUTMR read in conjunction with Article 7(1)(b) EUTMR. The relevant public are average German-speaking consumers, normally informed and reasonably attentive and knowledgeable, interested in photography, as amateurs or as professionals (para. 22). The contested mark is composed of two words: **Foto** (internationally understandable) and **Paradies**, understandable by the German-speaking public. **Lack of distinctiveness.** The term **Foto** is a common abbreviation of the German term ‘fotografie’ (meaning photography) and refers to the process of using light and chemicals to record an image. Meanwhile, the term **Paradies**, preceded by a noun, means in German an ideal place or it offers perfect conditions of well-being or for any activity or at



least represents an affirmative statement on the above noun. By connecting the term **Foto**, which for the German-speaking consumer refers to photography in general, with the term **Paradies**, the contested mark therefore refers to an ideal location for photography or a good price for a product, in the field of photography. It will be understood as a purely promotional message (para. 27). The contested mark's goods included in Classes 1, 9 and 16, may be sold as part of a large and multiple offer of a shop in the field of photography. The services included in Classes 38, 40 and 42, may all target the photography field. So, the contested mark will be perceived as a purely promotional message and will not be recognised as an indication of origin. The BoA rightly considered that the term will be recognised as an advertising slogan, which is not appropriate to indicate the commercial origin of the goods and services concerned (para. 29). **Foto Paradies** and 'Fotoparadies' will be understood in the same way by the relevant public, who will still perceive the mark as an advertising slogan (paras 31 and 32). Moreover, the contested mark is a word mark consisting exclusively of letters, words or associations of words, written in block letters in a normal font, without any specific graphic element, and the protection of such a mark is limited to the word and does not take into account possible figurative representations of the term. Therefore, even if in this case the two words are written with an upper-case letter, this does not change its meaning (paras 33 and 37). **Foto Paradies** and 'Fotoparadies' convey the same meaning, and the first one is written in full compliance with the rules of German grammar and corresponds to the German use of compound nouns, inasmuch as the first word specifies the meaning of the second word (para. 35). As the meaning of the two words **Foto** and **Paradies** remains the same if they are separated by a space or not, the contested mark has no originality nor does it require any effort of reflection or interpretation by the consumer (para. 36). Phonetically, it is not proved that the pronunciation of the two words will be perceptible orally, since the combined or separate writing of the two terms has no effect on the number of pronounced syllables, prosody or accentuation (para.38).

[T-279/17](#); **Push and Ready (fig.)**; *Hermann Bock GmbH v EUIPO*; Judgment of 15 March 2018; EU:T:2018:149; Language of the case: DE



The EUTM applicant sought to register the figurative mark above as an EUTM for goods in Classes 6, 10 and 20. The Office refused the registration of the EUTM application pursuant to Article 7(1)(b) EUTMR, as it was found to be devoid of distinctive character. The EUTM applicant appealed and the Board of Appeal (BoA) dismissed the appeal, since it found that the sign as a whole is completely devoid of any distinctiveness or originality and would instead immediately be perceived by the relevant consumers as a simple laudatory promotional statement. The EUTM applicant filed an action before the General Court (GC), relying on a single plea in law: infringement of Article 7(1)(b) EUTMR. **Relevant public.** The goods target specialists in the medical field and the general public. Since the verbal elements of the contested trade mark are English words, eligibility for protection must be assessed taking into account the English-speaking public of the EU (paras 24-25).



**Meaning of the mark.** The term ‘Push and Ready’ as a whole is immediately understood by the relevant public to mean that the goods, which are furniture in general, can be somehow used at the push of a button. The sequence of words is thus immediately perceived as an advertising slogan, which promotes the goods as seating and reclining furniture that can be assembled and used quickly and easily, and has a laudatory character (para. 28). Moreover, the graphic design of the sign is limited to the addition of some very common graphic elements. The red background, the white letters and the rounded triangular grey frame do not allow the consumer to commit the sign to memory and distinguish the goods in terms of their origin (para. 29). Furthermore, the horizontal tick or comma is a simple geometric shape and does not divert the consumer’s attention away from the meaning of the verbal elements (para. 39). Even if the contested mark had the shape of a guitar pick, first of all, it would be highly unlikely that the relevant public would recognise it, and, second, it would still be a simple geometric shape (para. 38). Registration of marks made up of signs or indications that are also used as advertising slogans, indications of quality or incitements to purchase the goods or services covered by those marks is not excluded by virtue of such use (para. 38). Moreover, the BoA referred generally to the use of the goods without including any specific hypothesis (para. 36). In any event, the other forms of using the mark, such as its use a shield put as a metal label on the goods, would not give distinctiveness to its verbal or figurative elements (para. 42).

♦[T-235/17](#); **MOBILE LIVING MADE EASY**; *Dometic Sweden AB v EUIPO*; Judgment of 22 March 2018; EU:T:2018:162; Language of the case: EN. The applicant sought to register the word mark **MOBILE LIVING MADE EASY** as an EUTM for goods and services in Classes 5 to 7, 9, 11, 12, 19 to 22 and 27. The Office refused the registration of the EUTM application pursuant to Article 7(1)(b) EUTMR, as it was found to be devoid of distinctive character. The applicant appealed and the Board of Appeal (BoA) dismissed the applicant’s appeal. The applicant filed an action before the General Court (GC) relying on two plea(s) in law: (i) infringement of Article 94 EUTMR and (ii) infringement of Article 7(1)(b) EUTMR. The statement of reasons for the contested decision enabled the applicant to understand how the BoA defined a homogenous category of goods and services in relation to which it used general reasoning (para. 20). By stating that the link between all the goods and services is that they ‘facilitate mobile life’, the BoA found that they all had a characteristic relevant to the examination of the absolute ground for refusal regarding a lack of distinctiveness and that they were all part of a homogenous category (para. 16). **Relevant public.** The relevant public is the English-speaking public (para. 49). **Meaning of the mark:** The relevant public will recognise in the contested mark the mere juxtaposition of the expressions ‘mobile living’ and ‘made easy’, therefore it will perceive the meaning ‘which facilitates mobile life’ (para. 49). **Perception of the mark.** The sign has a promotional meaning, which communicates a laudatory message as regards quality. It merely serves to highlight positive aspects of the goods and services, namely that they make it easy to have a mobile, travelling life. The contested mark will not therefore be perceived by the relevant public as an indication of the origin of the goods and services, but as an advertising slogan (para. 50). **Homogeneity of goods and services.** Despite their possible different characteristics, the goods and services belong to a homogenous category in the light of a common characteristic defined by reference to the meaning of the sign, namely ‘which facilitates mobile life’ (para. 32). It is sufficient that the goods are capable of being installed or used in vehicles serving as accommodation, such as caravans, motorhomes and boats and, as a result, facilitate mobile life (para. 43). The Board of Appeal was right in finding that the goods and services in question form a homogenous category, in that they facilitate mobile life in one way or another (para. 44).

[T-364/17](#); **HOUSE OF CARS**; *Marcin Bielawski v EUIPO*; Judgment of 17 April 2018;



EU:T:2018:193; Language of the case: PL. The applicant sought to register the word mark **HOUSE OF CARS** as an EUTM for goods and services in Classes 25, 35, 37 and 39. The Office refused the registration of the EUTM application pursuant to Article 7(1)(b) EUTMR, as it was found to be devoid of distinctive character regarding certain services in Classes 35, 37 and 39. The applicant's appeal was dismissed by the Board of Appeal (BoA) which considered it not distinctive. It found that the level of attention of the public was average or high. It also found that the sign was directly related to the contested services (which directly concern or may concern vehicles) to such an extent that the relevant public, immediately and without further reflection, would see in it the definition of the company's activity and its specialisation (the car industry). Therefore, the sign will not be perceived by the relevant public as an indication of the commercial origin of the service but just an indication of the services, industry or specialisation. The applicant filed an action before the General Court (GC) relying on two pleas in law: (i) infringement of Article 7(1)(b) EUTMR and (ii) infringement of the principles of legal certainty and legitimate expectations.

(i) **Relevant public.** The services concerned include both consumer services for the average consumer and services to be provided to professionals. Due to the nature of the services, the degree of attention of the relevant public will be high or at the level of an average consumer who is reasonably well informed and reasonably observant and circumspect (paras 24-25). The contested mark consists of elements that have a meaning in English and, therefore, the assessment of the nature of the mark must be carried out from the point of view of English-speaking consumers in the EU (para. 25). **Meaning and perception of the mark.** The word 'house' means a home or dwelling (building) but also a building having specific purpose, a company or institution. The word 'of' is a preposition or link that expresses belonging, and the word 'cars' means 'cars'. The word mark as a whole will be understood as a 'company running the vehicle-related business' or a 'car company' (para. 27). All services relate to vehicles: therefore, they share a common characteristic and they form part of a homogenous category of services. For instance, the services in Class 35 may all relate to vehicles insofar as vehicles may all be the object of auction sales, whereas services in Class 39 include all types of vehicles, namely cars (para. 38). **Lack of distinctiveness.** The sign will be perceived as an indication of the services, industry or specialisation, rather than an indication of the commercial origin of the service (para. 37).

(ii) The way in which the principles of equal treatment and sound administration are applied must be consistent with respect to legality. Moreover, for reasons of legal certainty and of sound administration, the examination of any trade mark application must be undertaken in each individual case. The BoA duly found that the mark was devoid of distinctive character, regardless of the previous Office decisions that accepted the registration of marks containing the word element 'house of' (paras 44-45).

♦ [T-297/17](#); **WE KNOW ABRASIVES**; *VSM. Vereinigte Schmirgel- und Maschinen-Fabriken AG v EUIPO*; Judgment of 24 April 2018; EU:T:2018:217; Language of the case: DE. The applicant sought to register the word mark **WE KNOW ABRASIVES** as an EUTM for goods and services in Classes 3, 7 and 35. The Office partially refused the registration of the EUTM application pursuant to Article 7(1)(b) EUTMR regarding the goods in Classes 3 and 7 and some services in Class 35 due to a lack of distinctiveness. For the remaining services in Class 35 (*advertising; business management; office functions; wholesaling in the fields of sanding machines, abrasive preparations, tools and goods of common metal for building; business administration*) no objection had been raised. The applicant appealed and the Board of Appeal (BoA) dismissed the appeal, insofar as it found that the slogan was non-distinctive, as the sign conveys an advertising statement. The applicant filed an action before the General Court (GC) relying on two pleas in law: (i) infringement of Article 7(1)(b) EUTMR and (ii) infringement of Article 66 and 67 EUTMR and Article 70(1) EUTMR.

**Relevant public.** The relevant public is the English-speaking general public or



professionals, since the mark is composed of three English words (para. 36). **Meaning of the sign and lack of distinctiveness.** The expression **WE KNOW ABRASIVES** is a word sequence that is formed from common English words (para. 39). The semantic content of the word mark (and each one of the words) is clear and precise (para. 40). Given the close connection between the sign and the goods and services concerned, as well as the ordinary character of the sign, the relevant public will immediately perceive the word mark, without further specific analytical or interpretative reflection, as a laudatory or promotional reference to the high quality and usefulness of the goods and services concerned (knowledge regarding abrasive products) and not as an indication of their commercial origin (para. 46). The word combination does not present, at a grammatical or syntactical level, any perceptible difference from the construction of an expression intended to convey the same message (para. 51). The syntactic variation is not such as to confer on the sign an unusual or ambiguous character (para. 50). The omission of the preposition which should, under the rules of English syntax, connect the verb with the object will not prevent the relevant public from grasping the meaning of the expression (para. 52). The adduced distinctiveness acquired by use of the mark **VSM — WE KNOW ABRASIVES** should have been based on the ground of Article 7(3) EUTMR, and, in any event, the signs are different due to the additional word element 'VSM' (paras 58-59). (ii) The BoA has exceeded its limits of jurisdiction by deciding to refuse to register services in Class 35 which had not been refused by the Opposition Division (OD) (para. 21). The applicant brought an appeal before the BoA against the OD's decision insofar as it refused all the goods and services except for some services in Class 35. The contested decision had to be annulled without any need to decide whether there had been an infringement of the right to be heard, as the BoA could only decide on the goods and services that had in fact been refused by the Office (paras 19-20).

♦[T-463/17](#); **RAISE**; *Raise Conseil v EUIPO*; Judgment of 3 May 2018; EU:T:2018:249; Language of the case: FR. The EUTM proprietor registered the word mark **RAISE** for goods and services in Classes 16, 35, 36 and 41. An application for invalidity was filed pursuant to Article 59(1)(a) EUTMR in conjunction with Article 7(1)(b) to (d) EUTMR. The Cancellation Division (CD) partially upheld the application for invalidity insofar as it found that the mark lacked distinctiveness regarding financial services. The EUTM proprietor appealed, but the Board of Appeal (BoA) dismissed the EUTM proprietor's appeal, finding that the mark would be perceived as a promotional and laudatory message since it designates an activity aimed at increasing financial wealth and value and developing the financial potential of clients and/or fundraising. The EUTM proprietor appealed to the General Court (GC), relying on three pleas in law: (i) infringement of Article 6 ECHR, (ii) infringement of Article 59(1)(a) EUTMR in conjunction with Article 7(1)(b) EUTMR, and (iii) infringement of Article 59(2) EUTMR in conjunction with Article 7(3) EUTMR. (i) Regarding the BoA's use of dictionary references as evidence, they were already used by the CD and were not challenged by the EUTM proprietor during the BoA proceedings. Even if they were taken into account by the BoA *ex officio* for the first time during the appeal proceedings, the BoA was entitled to do so as these refer to a well-known term (paras 29-30). (ii) **Relevant public.** The relevant public consists of EU English-speaking professionals who are particularly knowledgeable and attentive, as well as the general public with a high level of attention, as the services may have significant financial consequences for their users. The argument that the public in the United Kingdom should not be considered due to Brexit cannot succeed given that the United Kingdom was still a member of the EU when the contested decision was issued by the BoA (paras 51-52). **Meaning of the mark.** The word 'raise' means 'put up' or 'increase' (para. 53). **Direct link between the meaning of the mark and the services.** The expression 'raise' is a promotional and laudatory message referring to the fact that the services offered by the EUTM proprietor serve, in particular through fundraising, to increase



the financial wealth of its clients. The absence of the word ‘funds’ will not prevent the relevant public from creating a direct link between the mark and the services, since the mark **RAISE** will, implicitly but necessarily, make the public think of an increase in financial wealth (paras 54-55).

[♦T-387/17](#); **FORM EINES BALLÄHNLICHEN KÖRPERS MIT KANTEN (3D)**; *Triggerball GmbH v EUIPO*; Judgment of 16 May 2018; EU:T:2018:272; Language of the case: DE

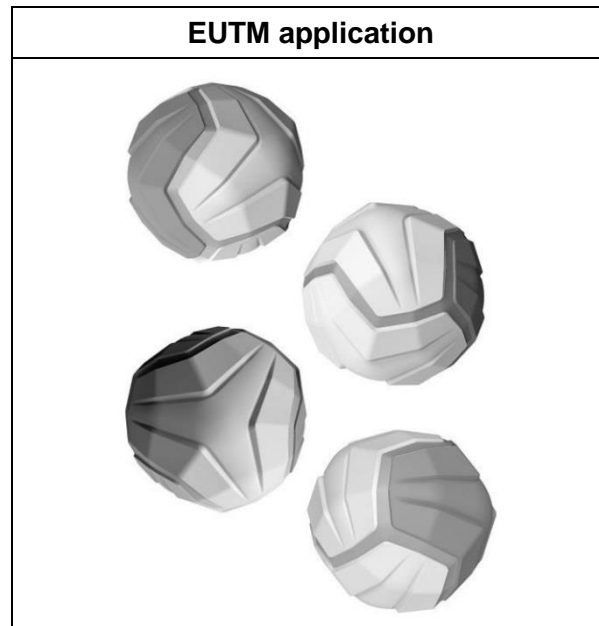

The applicant sought to register the 3D mark above as an EUTM for various goods in Classes 5 and 10. The Office partly refused the mark, citing Article 7(1)(b) EUTMR. The Board of Appeal (BoA) dismissed the applicant’s appeal. It found that the mark was non-distinctive for all the goods as the relevant public, whose level of attention was normal, would see nothing in the mark beyond the usual aspects of a massage ball. The applicant appealed to the General Court (GC), relying on one sole plea in law: infringement of Article 7(1)(b) EUTMR. **Relevant public.** Orthopaedic, massage and physical therapy articles, including massage balls, are frequently purchased by consumers displaying an average level of attention (para. 27). **Distinctiveness of the sign.** Novelty and originality do not endow a three-dimensional shape with the minimum degree of distinctiveness for registration by themselves (paras 28-29). Similarly, as the three-dimensional shape of a massage ball is not round but asymmetric, angular with lines framing these elements as if they were strips, and that the colour of the surface is not uniform, does not necessarily imply that the shape is endowed with intrinsic distinctive character (paras 31-33). Applicants must submit evidence to the Office demonstrating that the three-dimensional mark does not correspond to the usual form in its sector and that it is endowed with an intrinsic distinctive character (paras 34-36).

[T-299/17](#); **1000**, [T-300/17](#); **3000**, [T-301/17](#); **2000**, [T-302/17](#); **6000**, [T-303/17](#); **4000**, [T-304/17](#); **5000**; *Sata GmbH & Co. KG v EUIPO*; Judgment of 29 May 2018; EU:T:2018:309; Language of the case: DE. The EUTM proprietor obtained registration of the word marks **1000**, **2000**, **3000**, **4000**, **5000** and **6000** as EUTMs for goods in Class 7 (*paint spray guns*). An invalidity application was filed pursuant to Article 59(1)(b) EUTMR in conjunction with Article 7(1)(b) and (c) EUTMR. The Cancellation Division (CD) upheld the





invalidity application and the EUTM proprietor appealed. The Board of Appeal (BoA) dismissed the appeal as it found that the mark was descriptive and non-distinctive. The EUTM proprietor appealed to the General Court (GC) relying on four pleas in law: (i) infringement of Article 94 EUTMR; (ii) infringement of Article 7(1)(c) EUTMR; (iii) infringement of Article 7(1)(b) EUTMR; and (iv) infringement of the general principles of sound administration and equal treatment. (i) The first plea in law (violation of the duty to state reasons) is unfounded as the BoA decision contained reasoning. The objections and arguments intended to establish that the statement regarding the definition of the relevant public and the descriptiveness of the mark and its material correctness are irrelevant in the context of the duty to state reasons (para. 68). The aforementioned statement is well founded. Although succinct, the reasoning was sufficient (as well as clear and precise), all the more so since the EUTM proprietor was well aware of the context as the issue had already been raised before the CD (paras 71-73). (ii) The relevant public is composed both of professionals and the general public with a higher level of attention. The relevant territory is the EU as '1000', '2000', '3000', '4000', '5000' and '6000' exist in all EU languages (paras 36-37). The consumers, irrespective of whether they are members of the general public or specialists, are accustomed to the required operating pressure being specified on paint spray guns. Pounds per square inch (PSI) is a common unit used in the United Kingdom for measuring pressure (para. 38). There are paint spray guns with an operating pressure of up to 6 800 psi on the market. Irrespective of whether professional consumers possess the technical knowledge and know the detailed technical conditions of various types of paint spray guns, '1000', '2000', '3000', '4000', '5000' and '6000' are perceived as a description of the pressure by at least part of the relevant public, no matter what pulverisation technology is used, and regardless of the fact that the pressure indication ('psi') is not present. There is a sufficient link between the signs and the characteristics of the goods (paras 44-46). (iii) The descriptive signs are also devoid of any distinctive character in relation to those goods (para. 53). (iv) As the BoA examined the marks fully and according to the specific circumstances of the cases, there is no breach of the principles of legal certainty or sound administration (para. 60).

**T-362/17; FEEL FREE; NCL Corporation Ltd v EUIPO**; Judgment of 27 June 2018; EU:T:2018:390; Language of the case: DE. The applicant sought to register the word mark **FEEL FREE** as an EUTM for *arranging of cruises* and *cruise ship services* in Class 39. The Office refused to register the mark on the grounds of Article 7(1)(b) EUTMR. The Board of Appeal (BoA) dismissed the applicant's appeal. It found that the mark was non-distinctive for the services as it merely consisted of a laudatory slogan devoid of any elements which could, in addition to its promotional purpose, enable the public to memorise it easily and immediately as an indication of the commercial origin of the services. The applicant appealed to the General Court (GC), relying on one sole plea in law: infringement of Article 7(1)(b) EUTMR. **Relevant public.** Since the mark consists of English words and the services are offered to the public in general, the relevant public for examining the mark's distinctiveness are average English-speaking consumers (para. 35). **Distinctiveness of the sign.** The conjoined words 'feel' and 'free' constitute a banal, commonplace and grammatically correct expression with a simple, clear and evident meaning in English. Therefore, the mark does not trigger any particular cognitive process and is perceived simply and directly as a promotional slogan. It is not endowed with a minimum distinctive character (paras 37-40). There was no need to differentiate the services in Class 39 as the arguments that the mark has a minimum distinctive character apply to all of the application's services for identical reasons (para. 41) The fact that both words of the sign contain a double 'e' is not an element capable of conferring a distinctive character as that is something very frequent in English. Furthermore, the consonantal alliteration of 'f' is unlikely to be noticed by consumers, and even if it were, it will not be perceived as conferring a



distinctive character (para. 46). The allegation that the public is used to seeing slogans as trade marks has not been substantiated. Further, it is not decisive, as it does not explain why the sign would be perceived as more than a slogan, but as an indication of the commercial origin of the services (para. 48).

**T-691/17; SHAPE OF HOUSING FOR MEASURING TAPE;** *hoechstmass Balzer GmbH v EUIPO*; Judgment of 29 June 2018; EU:T:2018:394; Language of the case: DE

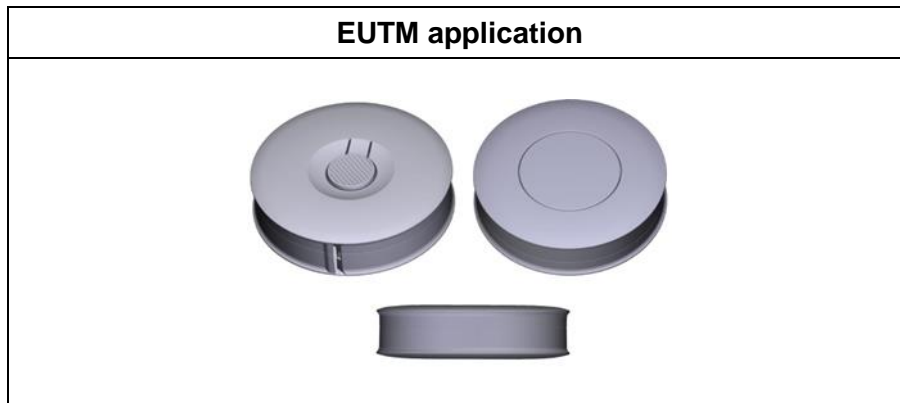

The applicant sought to register the shape mark above as an EUTM for goods in Class 9 (*measuring tapes*). The Office refused registration of the EUTM application pursuant to Article 7(1)(b) EUTMR, as it was found to be devoid of distinctive character. The applicant appealed and the Board of Appeal (BoA) dismissed the applicant's appeal due to lack of distinctiveness. The applicant appealed to the General Court (GC) relying on a single plea in law: infringement of Article 7(1)(b) EUTMR. **Relevant public.** The goods concerned can be used in any household, and they are simple, technically uncomplicated and generally low-priced (para. 31). The target public comprises average consumers in the EU, that are reasonably well informed, observant and circumspect (para. 32). **Representation of the shape mark.** The product is a housing inside which the actual measuring tape is affixed in such a way that it can be pulled out and will then automatically retract through a spring winding system. **Lack of distinctiveness.** (i) The form and presentation of the goods is absolutely standard and banal and has no special features whatsoever (para. 44). As regards the argument that the design resembles pill containers or powder boxes in an art nouveau style, since the recess in the middle part is barely visible in the images, or even inexistent in some images, it is unlikely that it will evoke the above to the average consumer (para. 37). (ii) Regarding the previous decisions of the German courts invoked by the applicant, even if they might prove the existence of originality in terms of competitive character, they would not respond to the question of registrability of the contested mark. In any event, existing registrations in Member States are only one of several factors which may be taken into consideration, without being given decisive weight, for the purposes of registering an EUTM (paras 52-53). **Scope of the proceedings.** As to the alternative request of limitation and partial annulment of the BoA's decision with regard to *measuring tape for tailors*, the claim is inadmissible, as it would be liable to change the subject matter of the proceedings (para. 59).



♦[T-222/14 RENV](#); **deluxe (fig.)**; *Deluxe Entertainment Services Group Inc v EUIPO*; Judgment of 4 July 2018; EU:T:2015:364; Language of the case: ES

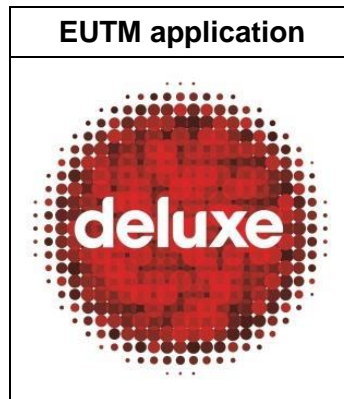

The applicant sought to register the figurative mark above as an EUTM for goods and services in Classes 9, 35, 37, 39, 40, 41, 42 and 45. The Office refused to register the mark for all the goods and services on the grounds of Article 7(1)(b) and (c) EUTMR. The Board of Appeal (BoA) dismissed the applicant's appeal. It found that the mark was devoid of any distinctive character and that the claimed acquired distinctiveness of the mark through its use had not been proven. The applicant filed an action before the General Court (GC) relying on five pleas in law. The GC annulled the contested decision of the BoA on the grounds that the BoA neither carried out the specific assessment required in Article 7(1)(b) EUTMR nor justified its decision for each of the goods and services. The Office lodged an action before the Court of Justice of the European Union (CJ). The CJ annulled the GC's decision and remitted the case to the GC for further assessment. **Alleged infringement of Article 94 and Article 7(1)(b) EUTMR.** The verbal element of the mark transmits the idea of 'superior quality' and also constitutes 'a direct reference to the concept of luxury'. This term, under both meanings, has a laudatory character and the public will immediately perceive it as a promotional formula that points out a positive characteristic of the goods (paras 46-47). 'Deluxe' constitutes a confirmation of a superior quality that belongs to the category of promotional tags, and being of 'superior quality' can be considered as a characteristic of all the goods and services involved. Thus, the public will immediately perceive this as a laudatory term referring to the goods and services instead of an indication of their business origin (para. 50). Despite the distinctive character of the figurative element of the mark applied for, the relevant public will understand the mark, considered as a whole — in particular due to the size and central position of its word element — as a direct and immediate confirmation of the superior quality of the designated goods and services, and not as an indication of their commercial origin. The sign is therefore devoid of any distinctive character (paras 57-59). The court confirms that all the goods and services designated in the application can be advertised as being of superior quality and that this is a pertinent characteristic for the assessment of the ground under Article 7(1)(b) EUTMR, on the basis of which they form a category sufficiently homogeneous to justify a common global motivation (paras 60-62).



**C-26/17 P; DEVICE OF A PATTERN (fig.); Birkenstock Sales GmbH v EUIPO;** Judgment of 13 September 2018; EU:T:2018:714; Language of the case: DE

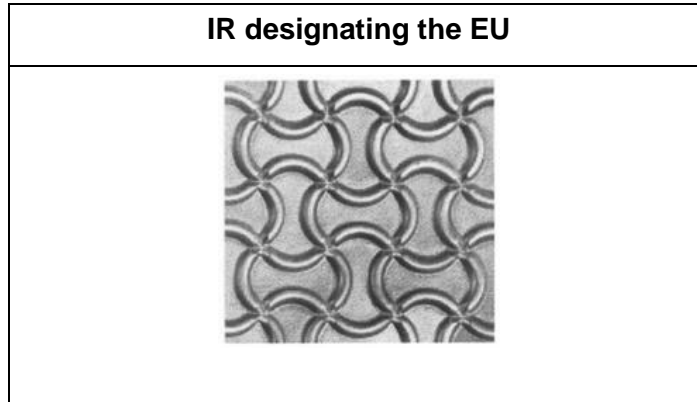

The predecessor in title of the applicant obtained an international registration (IR) designating the EU for the figurative mark above for goods in Classes 10, 18 and 25. The Office refused to grant protection of the IR in the EU, pursuant to Article 7(1)(b) EUTMR, as the mark was found to be devoid of distinctive character for all the goods concerned. The Board of Appeal (BoA) dismissed the applicant’s appeal. It found that the relevant public would, in all likelihood, perceive the sign as a simple surface pattern and not as an indication of any particular commercial origin. The applicant filed an action before the General Court (GC), relying on a single plea in law: infringement of Article 7(1)(b) EUTMR. The GC partially dismissed the action. It found that the Bo A had been correct to apply the case-law relating to signs that are indissociable from the appearance of the goods. The applicant went on to appeal against the judgment of the GC before the Court of Justice of the European Union (CJ), invoking three grounds in support of its appeal: (i) infringement of Article 7(1)(b) EUTMR, (ii) contradictory reasoning in the judgment under appeal, and (iii) distortion of the facts. **Criteria for assessing the distinctive character of signs consisting of a design applied to the surface of a product.** The sign at issue is a figurative sign made up of a series of elements that are repeated regularly and that can be extended *ad infinitum* in all four directions, thereby lending itself particularly well to being used as a surface pattern. Some of the sign’s goods are ones that will obviously often display surface patterns, such as fashion items in the broad sense of the term, while it is less obvious that others will display surface patterns. It is only when a surface pattern is unlikely, due to the nature of the goods at issue, that such a sign cannot be considered a surface pattern for those goods (para. 39). The GC did not err in law when it used the criterion of the possible, and not unlikely, use of the sign as a surface pattern in the light of the nature of the goods concerned, in order to apply the case-law relating to three-dimensional marks that are indissociable from the appearance of the goods (para. 40). Firstly, due to the intrinsic characteristics of the sign at issue, which is made up of a series of regularly repeated elements, and the nature of the relevant goods, the sign is, in principle, intended to be affixed to the surface of those goods. There is therefore an inherent probability that a sign consisting of a repetitive sequence of elements will be used as a surface pattern and will therefore be indissociable from the appearance of the goods concerned (para. 41). Secondly, the criterion of the most likely use adopted in the order of 26 April 2012, *Deichmann v OHIM* (C-307/11 P, EU:C:2012:254, paragraph 55), is irrelevant, given that the case which gave rise to that order did not concern the registration of a sign made up of a repetitive sequence of elements, but rather of a sign representing a curved band with dotted lines (para. 42). And thirdly, compliance with the criterion of the most likely use, as invoked by the appellant, would lead to it being possible for signs that



lend themselves particularly well by reason of their intrinsic characteristics to be used as a surface pattern for the goods covered, to avoid the case-law relating to marks that are indissociable from the appearance of the goods being applied to them (para. 43).

**T-184/17; DARSTELLUNG VON VIER GRÜNEN QUADRATEN (posit.);** *Leifheit AG v EUIPO*; Judgment of 13 September 2018; EU:T:2018:537; Language of the case: DE

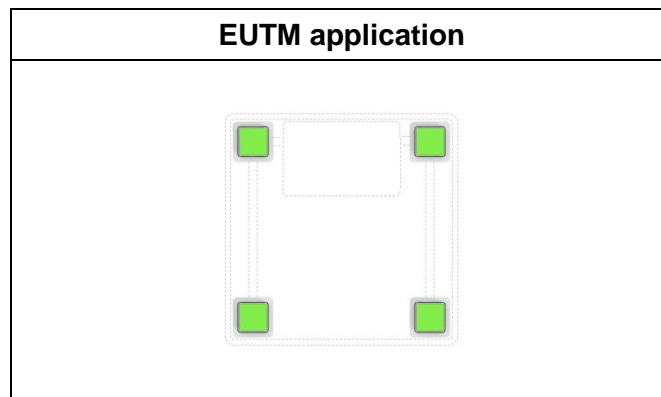

The applicant sought to register the position mark above as an EUTM for *balances; weighing scales; kitchen scales; household scales; analysis scales; scales for measuring fat mass; heat control apparatus* in Class 9. In the application for registration, the sign applied for is described as follows, ‘The position mark consists of a total of four green squares on the underside of a scale at each corner near the edge. The dashed lines indicate the position of the mark and are not part of the mark’. The Office refused to register the EUTM application pursuant to Article 7(1)(b) EUTMR, as it was devoid of distinctive character. The applicant filed an appeal, which was dismissed by the Board of Appeal (BoA). It found, firstly, that the mark applied for was inseparable from the rectangular shape of the goods for which protection was sought, which would be evidenced not only by the dashed lines, but also by the description; secondly, that because of its simple and purely decorative configuration, the relevant public would not perceive the mark applied for as an indication of origin; and thirdly, that the decorative possibilities of the surfaces of the goods in question were unlimited. The applicant appealed to the General Court (GC), relying on one single plea in law: infringement of Article 7(1)(b) EUTMR. **Position marks.** The mark applied for, which seeks the protection of a specific sign on a particular part of the goods in question, will be confused by the relevant public with the appearance of these products, the mark being inseparable from the shape of the underside of a scale (paras 31-32). Specifically, in view of the most likely use of the mark applied for, the mark is inseparable from the four feet of a scale which form an integral part of the figurative form and representation of the product (para. 34). On the possibility that the goods at issue are designed with convex or concave sides, it does not follow from previous case-law that a mark is identical with the appearance of the product concerned only if it adapts automatically to a change of shape (para. 33). **Distinctiveness.** The mark does not significantly depart from the standard or habits of the sector as, firstly, the square shape of the elements of the mark applied for constitutes a basic form not likely as such to convey a message that consumers might remember (para. 46). Secondly, it is positioned to coincide with the usual positioning of the feet of weighing scales, ensuring the stability and operation of the products concerned (para. 48). Thirdly, the light green colour chosen by the applicant for the four squares is not particularly vivid or striking (para. 49) nor especially unusual in the sector concerned (paras 56-58).



**T-457/17; happy life; Medisana AG v EUIPO;** Judgment of 25 September 2018; EU:T:2018:599; Language of the case: DE. The applicant sought to register the word mark **happy life** as an EUTM for goods in Classes 8, 10 and 11. The Office refused to register the EUTM application pursuant to Article 7(1)(b) EUTMR for *erotic articles* in Class 10, on the ground that it was devoid of distinctive character. The applicant filed an appeal. The Board of Appeal (BoA) dismissed the appeal. It found that the word sequence will be immediately understood by the public targeted as a laudatory, promotional statement, according to which the goods thus designated aim to help the buyer achieve a happy life. As a general promise of particular satisfaction to the customer, the sign conveys an advertising statement, and is therefore not capable of identifying the goods as originating from a particular undertaking. The applicant filed an action with the General Court (GC), relying on a single plea in law: infringement of Article 7(1)(b) and Article 7(2) EUTMR.

**Relevant public.** Since the word mark consists of two English words, the relevant public is the English-speaking public and the goods target the end consumer. Pursuant to Article 7(2) EUTMR, it is not necessary to examine the application from the view of all EU consumers (paras 25, 27). **Meaning of the sign and perception of the public.** The expression ‘happy life’ will be immediately perceived by the relevant public as a laudatory, promotional statement, according to which the goods concerned aim to help the buyer achieve a happy life (paras 24, 28). It contains a promise that makes reference to a characteristic relating to the market value of the goods which, while not specific, comes from advertising information which the relevant public will perceive as such (para. 35). The sign is therefore devoid of any originality or resonance, and fails to trigger in the minds of the relevant public a cognitive process or interpretative effort (para. 29). No other possible meanings would serve to indicate the commercial origin of the goods concerned for the relevant consumer (para. 30). Although the short length of the mark makes it easier to remember, this does not imply that it is perceived as an indicator of origin (para. 39).

**Principle of legality.** As regards the other signs the applicant refers to in order to prove that other manufacturers also use similar resonant expressions in their signs, the latter are different signs. The way in which the principles of equal treatment and sound administration are applied must be consistent with respect for legality. An application for registration of a sign as a trade mark cannot rely, to the applicant’s advantage and in order to secure an identical decision, on a potentially unlawful act committed to the benefit of another (paras 44-45). **Lack of distinctiveness.** Contrary to the applicant’s claim, the BoA did not apply the strictest criteria in order to assess the distinctive character of the sign, since the latter has no distinctiveness whatsoever (para. 32). The applicant itself describes the sign as a slogan in its application (para. 34). The BoA did not dismiss the appeal solely because the sign was a promotional slogan, but also because it was incapable of identifying the product as originating from a particular undertaking (para. 36). Given the above, the sign is devoid of any distinctive character whatsoever regarding the goods concerned (para. 46).

**Subject of dispute.** As to the applicant’s argument that the reasoning is inconsistent since the application was accepted for similar goods, the latter are not part of the dispute (Article 67 EUTMR, first sentence) (paras 48-50).



**T-595/17; GELB-GRAU (fig.); Demp BV v EUIPO**; Judgment of 27 September 2018; EU:T:2018:609; Language of the case: DE

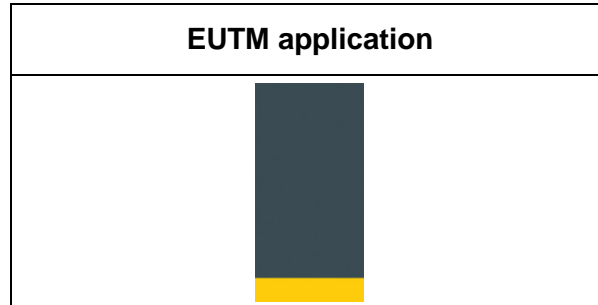

The applicant sought to register the colour mark above as an EUTM for goods and services in Classes 6 to 9, 11, 17, 20, 21, 28 and 35. The Office refused the application pursuant to Article 7(1)(b) EUTMR, on the ground that it was devoid of distinctive character. The applicant filed an appeal. The Board of Appeal (BoA) dismissed the appeal. It found that for some of the goods in question the dominant grey colour was the natural colour of the material of the products concerned, and the yellow colour had only decorative purposes. The relevant public would perceive it as a sign composed of two ordinary colours forming a purely decorative element of the product, packaging or advertising material and not as a sign providing a clear indication of origin. Furthermore, the applicant did not prove its allegation that company-specific colours were a common concept in the garden tools market. The applicant appealed to the General Court (GC), relying on two pleas in law: (i) infringement of Article 4 EUTMR, Article 7(1)(b) EUTMR and the principle of equality, and (ii) infringement of Article 94 EUTMR. It is apparent that the BoA previously examined the grey and the yellow colours separately and then the mark as a whole and in proportion (para. 34). Contrary to the applicant's allegations, the BoA did not deny that the colour yellow, in general and regardless of the actual manner in which it is used, could serve as an indication of origin, but simply observed that in the colour combination requested it would be perceived as fulfilling a decorative purpose (para. 47), whereas the dominant grey colour was the natural colour of many of the products concerned (para. 50). It cannot be inferred from the fact that a mark consists of a combination of a small number of colours that it necessarily has distinctive character (para. 64). The applicant's unsubstantiated assertions that the colour combination of the trade mark applied for was original, unusual and memorable, cannot serve to call into question the assessment of the BoA, according to which the mark applied for cannot serve as an indication of origin without having been the object of long-term use, nor to challenge the lawfulness of the contested decision (para. 65). As the BoA observed, it is true that the grey colour, which occupies a large part of the mark applied for, is of an ordinary character and may go unnoticed, and that, moreover, it constitutes the natural colour of the material of a number of the products concerned. Furthermore, the colours composing the mark applied for, even if they are associated, are by no means exceptional in advertising the goods and services designated by that mark, and their combination may evoke a decorative element of the product, packaging or advertising material for the relevant public (para. 66). The applicant does not explain the link which must be made between the alleged distortion of the facts of the case by the BoA and the obligation to state reasons provided for in Article 94 EUTMR (para. 72). The applicant's action must be rejected in its entirety.

**T-697/17; COOKING CHEF GOURMET**; *De Longhi Benelux SA v EUIPO*; Judgment of 9 October 2018; EU:T:2018:661; Language of the case: EN. The applicant sought to register the word mark **COOKING CHEF GOURMET** as an EUTM for *electric food mixers*



*incorporating an induction cooking (heating) element; attachments for the aforesaid electric food-mixers, all for blending, liquidising, pureeing, mashing, mixing, pulping, kneading, rolling, grinding, mincing, chopping, slicing, grating, shredding, peeling, cutting, crushing, sieving, beating and whisking of foodstuffs; blades adapted to fit the aforesaid electric food mixers; mixing bowls and blender jugs adapted to fit the aforesaid electric food mixers; parts and fittings of the aforesaid electric food mixers, namely electric motors in Class 7 and induction cooking apparatus incorporating a food mixing or a food processing function in Class 11.* The Office refused to register the EUTM application pursuant to Article 7(1)(b) EUTMR, as it was devoid of distinctive character. The applicant appealed, which the Board of Appeal (BoA) dismissed. It found that in the English-speaking part of the EU territory, the elements of the mark described the purpose of the goods concerned, were laudatory and commonly used to describe food and drink, with the result that they would not be perceived as an indication of the commercial origin of the goods. The applicant filed an action before the General Court (GC), relying on a single plea in law: infringement of Article 7(1)(b) EUTMR. **Inherent distinctive character of the mark.** Even though the BoA first examined the meaning of the words ‘cooking’, ‘chef’ and ‘gourmet’ separately, it also considered the meaning of the combination of these words, before proceeding to examine the overall impression given by the word mark. It concluded that the relevant public would understand the expression ‘cooking chef gourmet’ as a laudatory indication that the goods concerned are capable of preparing fine food and drinks, as a cook would (paras 23-24). The mark applied for, which is made up of three everyday English words whose respective meanings are not disputed, will be perceived immediately by the relevant public as a laudatory or promotional reference to the qualities and purpose of the goods concerned (paras 27-29). The fact that the three elements comprising the word mark ‘cooking chef gourmet’ are juxtaposed does not mean that the mere omission of an article or preposition in its structure, [for] cooking [like] [a] gourmet chef, is sufficient to make it a lexical invention liable to give distinctive character to that sign (para. 34). The group of words ‘cooking chef gourmet’ as a whole, does not entail, grammatically or syntactically, any perceptible difference as regards the construction of a sentence that will be understood merely as a laudatory reference to the goods concerned, which allow the relevant public to cook like a real gourmet and chef. In those circumstances, the relevant public does not need to make a particular effort as regards the interpretation of the sign in order to understand the meaning of the sign applied for (para. 35). The mark is not ambiguous and will not be perceived by the relevant public as an indication of the commercial origin of the goods in question (paras 36, 38). **Level of attention of the relevant public.** Although some of the application’s goods in Classes 7 and 11 may have a relatively high purchase price and be used over a number of years, it must nevertheless be noted that most of those goods are kitchen utensils, which do not require particular technical knowledge nowadays (para. 43). Moreover, the level of attention of the relevant public may be relatively low regarding promotional indications, whether it involves the general public or a more attentive public made up of specialists or circumspect consumers, even if, as is the case here, some of the goods concerned require a relatively significant financial commitment. Accordingly, the BoA was entitled to take the view that the relevant public, made up of the general public and the specialised public, had an average level of attention with regard to the mark applied for, on account of its promotional nature (paras 43-44). **Reputation of the applicant’s earlier mark ‘CHEF’.** To the extent that the applicant claims that the mark applied for has acquired a distinctive character owing to the earlier registration of the CHEF mark, which is allegedly widely known and has been subject to long-standing and intensive use since the 1950s, that argument must be rejected as irrelevant. This argument may have been relied on in support of a claim seeking the Office’s recognition that the mark applied for has distinctive character acquired through use under Article 7(3) EUTMR. However, the earlier registration on which the applicant bases its argument concerns the word mark CHEF, which differs





from the sign that forms the subject matter of the present action, as it also includes the word elements ‘cooking’ and ‘gourmet’ (paras 49-51).

**C-433/17 P; GREEN STRIPES ON A PIN (col.); Enercon GmbH v EUIPO**; Judgment of 25 October 2018; EU:T:2018:860; Language of the case: EN

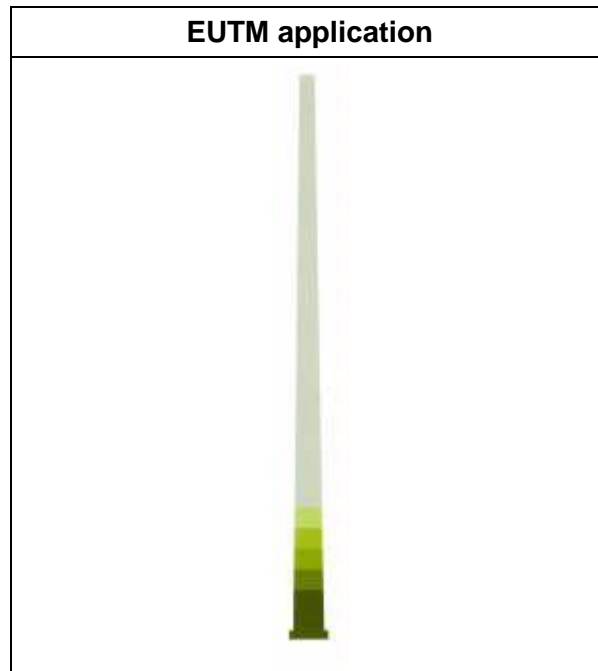

The trade mark applicant sought to register the sign above, identified as a colour mark, for goods in Class 7. An invalidity application was filed pursuant to Article 59 EUTMR. The Cancellation Division (CD) upheld the invalidity application on the basis of Article 7(1)(b) EUTMR. The trade mark applicant filed an appeal, which the Board of Appeal (BoA) upheld, therefore annulling the CD’s decision. The invalidity applicant filed an action with the General Court (GC), which partially upheld the action and annulled the BoA decision (12/11/2013, T-245/12, GREEN STRIPES ON A PIN (col.), EU:T:2013:588). The case was remitted to the BoA, which ruled that the contested mark was a colour mark and not a figurative mark, and that the CD had correctly found that it lacked distinctive character. The trade mark applicant filed an action with the GC. The GC dismissed the action in its entirety. The trade mark applicant appealed to the CJ on two grounds: (i) that the GC had erred in law in taking the view that the designation of the contested mark as a colour mark in the application form determined the nature of the mark in law and therefore affected the assessment of its inherent distinctive character and (ii) that the GC had erred in dismissing information presented by the trade mark applicant, which had in turn led it to the erroneous finding that the contested mark was a colour mark. **On the first ground of appeal.** The designation of the category of mark by the applicant for registration of an EUTM is a legal requirement (para. 23). Article 49(2) EUTMR does not authorise the category of EU trade mark chosen by the applicant in its application to be changed to another category of mark (para. 24). The GC was therefore fully entitled to take the view that the distinctive character of the mark had to be assessed according to the category of mark chosen (para. 27). It follows that the first ground of appeal must be rejected (para. 28). **On the second ground of appeal.** Although INID code 546 is referred to in the registration certificate, the appellant at no time mentioned that code during the procedure before the Office. On the contrary, it explicitly chose to have its mark registered as a colour mark (para. 37). It is neither for the



Office nor for the GC to reclassify the category chosen for a mark. It cannot be held that the Office is required to decipher of its own motion all of the documentation filed when registration of a ‘colour mark’ is applied for in order to decide on its own initiative that the mark in question is to be reclassified as a ‘figurative mark’ outside the legal framework laid down by the applicable rules on trade marks (para. 38). It follows that the second ground of the appeal must be rejected (para. 39). Consequently, the appeal must be dismissed in its entirety (para. 40).

[♦T-460/17](#); **DARSTELLUNG EINES GLEICHWINKLIGEN ACHTECKS**; *Carsten Bopp v EUIPO*; Judgment of 21 November 2018; EU:T:2018:816; Language of the case: DE

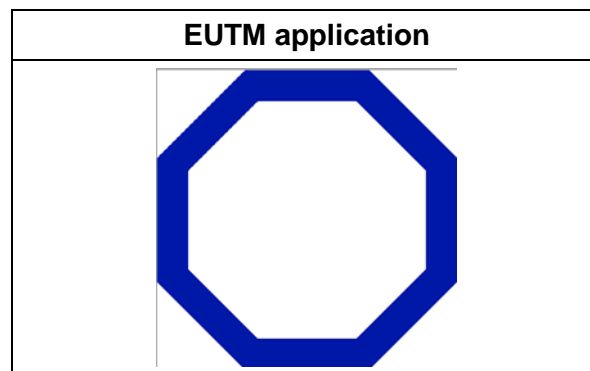

The applicant sought to register the figurative mark above claiming the colour ‘blue’ as an EUTM for the goods and services in Classes 16, 42 and 45. The examination proceedings were stayed until the final outcome on the registrability of the applicant’s parallel EUTM application for a green octagonal frame. When the Court of Justice (C-653/15) dismissed the appellant’s appeal regarding the latter, confirming that the parallel EUTM application lacked distinctive character, the Office gave the applicant the opportunity to submit observations on the judgment. The Office did not receive any observations. Irrespective of this fact, it refused the EUTM application referring to the ECJ judgment. The applicant appealed, claiming before the Boards of Appeal (BoA) that (i) it submitted observations that were not taken into account, (ii) it was never given the opportunity to submit observations regarding the claim that the EUTM application was not registrable in part of the EU and (iii) the EUTM application was distinctive. The BoA dismissed the appeal confirming non-distinctiveness of the mark. Taking into account the judgment regarding the green octagonal frame, the Office refused the EUTM application, and therefore it was up to the applicant to prove that the contested mark would be perceived as an indication of the origin. The applicant filed an action before the General Court (GC), relying on two pleas in law: (i) infringement of Article 7(1)(c) EUTMR and (ii) infringement of Article 94 EUTMR. **As regards the distinctive character.** The BoA correctly endorsed the analysis carried out in line with judgment T-209/14 (Green octagonal frame) (para. 59). The EUTM application is devoid of distinctive character across the EU. The sign is a regular, blue-coloured octagon. Compared to a simple octagon, an octagonal frame does not possess any perceptible difference that would be capable of attracting the attention of the relevant public to any greater extent. As a purely decorative element, such as a blue seal or label or a blue outline, the exact meaning of the seal or label is not obvious, consequently, the sign will not be perceived as a commercial identification (para. 57). In the absence of any additional text or images, or any other particular measures (continued advertising, etc.), the relevant public (both general and specialised) would not be able to assign the contested mark to a specific undertaking (para. 63). When an applicant challenges the Office’s assessment of non-distinctiveness, it is up to that applicant to provide specific and substantiated information to



show that it has either an intrinsic distinctive character or a distinctive character acquired by usage (para. 60). The applicant did not substantiate its argument that the mark was unusual (para. 62). The mark is in fact very simple and does not contain any element which could be perceived as an indicator of origin (para. 63).

**T-824/17; H2O+ (fig.); H2O Plus LLC v EUIPO**; Judgment of 27 November 2018; EU:T:2018:843; Language of the case: EN

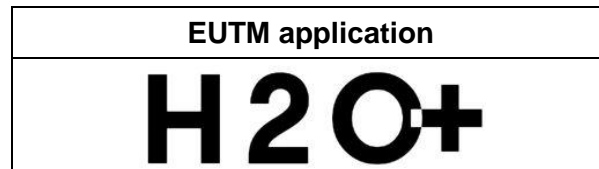

The applicant filed an application for protection of the figurative sign above for the goods in Classes 3 and 5. The Office notified the applicant of the provisional refusal of protection of the sign covered by the international registration on the basis of Article 7(1)(b) and (c) EUTMR and of Article 7(2) EUTMR for all the goods for which protection was sought. Following the applicant's observations, the Office refused protection. The applicant filed an appeal against the Office's decision. The Board of Appeal (BoA) dismissed the appeal holding that in relation to the goods concerned, namely cosmetic goods and medicated sunscreens, the sign at issue was devoid of distinctive character for the relevant public. The applicant filed an action with the General Court (GC), relying on two pleas in law: (i) infringement of Article 7(1)(b) EUTMR and (ii) infringement of Article 7(1)(c) EUTMR. The relevant public was composed of consumers of the goods for which protection was sought in the European Union, reasonably well informed, reasonably observant and circumspect, and whose level of attention is average (para. 19). This public would effortlessly perceive the sign at issue as consisting of the chemical formula for water (H<sub>2</sub>O) and the mathematical sign '+' (para. 21). The overall impression produced by the sign at issue will be dominated by the element 'h<sub>2</sub>o' (para. 23). It seems unlikely to be the case, that an average consumer may read the element 'h<sub>2</sub>o +' not as meaning 'water plus', but as a sign consisting of two separate and distinct elements, each without meaning, namely, first, 'h<sub>2</sub>' and, second, the Venus sign in a horizontal position (para. 28). Although hydration is not of 'key importance' for all the goods in question, goods like these that are intended to protect the skin have, directly or indirectly, a moisturising effect (para. 29). The sign '+' alludes to a positive or additional element, and thus, the sign is perceived as referring to a certain quality or characteristic of the goods in that they provide better or extra hydration (para. 30). The fact that some of the goods do not consist primarily of water cannot suffice to conclude that the public will not perceive the sign as an indication of such characteristic (para. 31). The sign at issue was devoid of distinctive character, because it refers simply and in essence, in the mind of the relevant public, to a positive or appealing quality and function of the goods at issue (para. 34). The mark applied for was caught by the ground for refusal laid down in Article 7(1)(b) EUTMR (para. 37). Since one absolute ground for refusal sufficed for the sign not to be registered, it was not necessary to consider whether the sign at issue should also be refused registration pursuant to Article 7(1)(c) EUTMR (para. 40).

♦ **T-214/17; FUNNY BANDS**; *Out of the blue KG v EUIPO*; Judgment of 29 November 2018; EU:T:2018:854; Language of the case: EN. The EUTM proprietors registered the word mark **FUNNY BANDS** as an EUTM for goods and services in Classes 14, 17 and 35. An invalidity application was filed pursuant to Article 59 EUTMR in conjunction with Article 7(1)(b) and (c) EUTMR. The Cancellation Division (CD) dismissed the invalidity application. The invalidity applicant filed an appeal. The Board of Appeal (BoA) dismissed



the appeal. It found that the mark had an obscure meaning as regards the goods and services concerned and was thus not descriptive nor lacking in distinctive character. The invalidity applicant filed an action with the General Court (GC), relying on three pleas in law: (i) infringement of Article 7(1)(b) EUTMR, (ii) infringement of Article 7(1)(c) EUTMR and (iii) infringement of the principles of equal treatment and the protection of legitimate expectations. At the hearing before the GC, the invalidity applicant withdrew part of its action and stated that it was challenging the CD decision only insofar as it confirmed the CD rejection of the invalidity application for part of the goods and services. **Lack of distinctive character.** Since the BoA concluded that the mark was not devoid of distinctive character based solely on the fact that it was not descriptive of the goods and services, and the GC has found that the analysis of descriptiveness is vitiated by an error of assessment, the contested decision must also be annulled on the ground for refusal set out in Article 7(1)(b) EUTMR (paras 53-54). **Partial annulment of the BoA decision.** The BoA decision must be annulled insofar as it rejected the invalidity applicant's action with respect to the part of the goods and services not concerned by the withdrawal at the hearing before the GC. It is not necessary to examine the applicant's third plea in law (para. 55).

**T-102/18; upgrade your personality; *Martin Knauß v EUIPO***; Judgment of 13 December 2018; EU:T:2018:932; Language of the case: DE. The applicant sought to register the word mark **upgrade your personality** as an EUTM for goods and services in Classes 9, 28 and 42. The Office refused to register the EUTM application pursuant to Article 7(1)(b) EUTMR for part of the goods, namely those in Classes 9 and 28, as it was devoid of distinctive character for those goods. The applicant filed an appeal. The Board of Appeal (BoA) dismissed the appeal. It found that the word mark had a purely laudatory and promotional purpose and was not able to fulfil the basic function of a trade mark, that of indicating the origin of the goods. The applicant filed an action with the General Court (GC), relying on one sole plea in law: infringement of Article 7(1)(b) EUTMR. **Relevant public.** The goods for which registration was refused belong to the field of software and video games and are primarily intended for the average consumer. Since the trade mark consists of basic English words and this language is commonly used in the field of computing, account should be taken of the English-speaking consumers in the European Union including those residing outside the United Kingdom or Ireland (para. 22). **Distinctiveness.** The slogan 'upgrade your personality' includes an invitation to the consumer to improve or develop his or her personality through the application's goods, implicitly accompanied by the promise that the goods will facilitate said improvement or development (para. 28). The term 'upgrade' is currently used in contexts that go far beyond the field of computing, and the application's goods belong to the computing sector, so the use of this term appears normal and the relevant public will not find it surprising (para. 29). It is irrelevant whether it is impossible to improve someone's personality in the technical sense (upgrade), since this is an advertising slogan in which the proximity to reality is not a pertinent assessment. Consumers are used to advertising messages that make tacit or explicit unrealistic promises (para. 30). Insofar as the applicant relies on the registration by the Office of word marks allegedly similar to the mark applied for, it should be recalled that the BoA's decisions are adopted in the exercise of circumscribed powers and are not a matter of discretion. Accordingly, the legality of those decisions must be assessed solely on the basis of the EUTMR as interpreted by the courts and not on the basis of previous decisions by the Office (para. 33). The action brought against the Office's decision concerned only the refusal to register the mark for certain goods. The fact that the Office did not raise objections concerning the other goods and services for which protection was sought was not part of the dispute before the BoA. Consequently, there was no reason for the BoA to comment on the reasons why the Office did not raise objections to certain goods or services, or on the question of why the goods and services the Office did not raise objections for differed from those for which the



registration was refused (para. 39). The applicant's sole plea in law, and therefore the action as a whole, must be dismissed (para. 40).

**T-94/18; fit+fun; Multifit Tiernahrungs GmbH v EUIPO**; Judgment of 13 December 2018; EU:T:2018:933; Language of the case: DE. The applicant sought to register the word mark **fit+fun** as an EUTM for goods in Classes 3, 5, 18, 19, 20, 21, 28 and 31. The Office refused to register the EUTM application pursuant to Article 7(1)(b) and (c) EUTMR. The applicant filed an appeal, which the Board of Appeal (BoA) dismissed. It found that the mark was devoid of distinctive character, as it comprised common advertising terms that, by their laudatory nature, encouraged consumers to purchase the goods in question. The overall impression produced by the mark was no different from that produced by the sum of its parts. The applicant filed an action with the General Court (GC), relying on a single plea in law: infringement of Article 7(1)(b) EUTMR. **Relevant public.** The relevant public is both the general public, especially pet owners, and experts, in particular specialist traders in the pet industry. As the contested trade mark is made up of two English words, the relevant public consists of English-speaking consumers in the EU. Depending on the type of goods concerned, the degree of attention is average to high (para. 19). All the contested goods are intended for animals and most of them promote animal welfare (para. 20). **Meaning of the mark and laudatory character.** The trade mark will be understood as 'fit and fun' or as 'suitable and fun' (para. 22). 'Fit+fun' does not contain any elements that are unexpected or surprising. Rather, it brings together simple and common terms that are particularly popular in the world of advertising; it also lacks originality. It certainly does not trigger a cognitive process or require interpretative effort, nor would the relevant public perceive a contradiction between the two terms (paras 25, 28). The mere fact that the word mark does not convey any information about the nature of the goods concerned or describe the characteristics of the goods is not sufficient to make that sign distinctive (paras 28, 52). Although a slogan can have a number of meanings, constitute a play on words or be perceived as imaginative, surprising and unexpected, the existence of such characteristics is not a necessary condition for establishing that an advertising slogan has distinctive character (para. 47). The ruling cited by the applicant (02/12/2008, T-67/07, Fun, EU:T:2008:542) is irrelevant since it essentially inferred that the sign 'FUN' had no distinctive character from the fact that it was descriptive, but no ruling was made regarding the distinctiveness of the sign per se (para. 45).

## 2. **Outcome: Distinctive (Article 7(1)(b) EUTMR)**

♦**T-60/17; TSA LOCK; Safe Skies LLC v EUIPO**; Judgment of 22 March 2018; EU:T:2018:164; Language of the case: EN. The applicant sought to register the word mark **TSA LOCK** as an EUTM for goods and services in Classes 6, 18 and 20. An application for invalidity was filed pursuant to Article 59 EUTMR in conjunction with Article 7(1)(b), (c), (d), (g) and (i) EUTMR. The Cancellation Division (CD) dismissed the application for invalidity. The Board of Appeal (BoA) dismissed the invalidity applicant's appeal. It found, inter alia, that the invalidity applicant had failed to establish that the sign was descriptive or devoid of any distinctive character. In that respect, it held that the relevant date for the purposes of assessing the case was that on which the application for registration of the contested EU trade mark was filed and that none of the evidence was sufficient to prove that, on the relevant date, the sign was perceived by the relevant public as descriptive or devoid of any distinctive character. The invalidity applicant filed an action before the General Court (GC) relying on a single plea in law: infringement of Article 59(1)(a) in conjunction with Article 7(1)(b), (c) and (g) EUTMR. **Distinctiveness.** Since the contested mark contains a word with an English meaning, the relevant public consists of the English-speaking



consumers in the European Union. The relevant goods are directed both to the public at large in these Member States and to business professionals, for example manufacturers and retailers in the field of travel luggage (para. 29). The BoA was correct to hold that the relevant date was that on which the application for registration was filed (para. 25). However, all the evidence is dated after the filing of the application for registration and/or contains material which does not relate to the situation at the date of the filing of the application for the contested mark (paras 26-27). Admittedly, the word mark ‘lock’, which is generally understood to mean a ‘locking mechanism’ or ‘padlock’, is not apt to distinguish such goods from those of other undertakings and therefore cannot confer on the contested mark a distinctive character (para. 34). Furthermore, there is no proof that the relevant public associates the abbreviation TSA with the ‘Transport Security Administration’. Since that abbreviation lacks a meaning that could be immediately perceptible by the relevant public, the contested mark could not be understood by that public as a reference to the Transportation Security Administration (para. 39). It is in no way apparent from an overall examination of the word mark **TSA LOCK** that the trade mark was perceived by the relevant public at the date of filing of the application for registration as being devoid of distinctive character (para. 49).

♦[T-207/17](#); **hp (fig.)**; *Senetic S.A. v EUIPO*; Judgment of 24 April 2018; EU:T:2018:396; Language of the case: EN



The intervener applied for an EU trade mark for the figurative mark above for goods and services in Classes 2, 7, 9, 16, 35 to 38 and 40 to 42. The applicant applied for a declaration of invalidity on the basis of Article 59(1)(a) EUTMR, read in conjunction with Article 7(1)(b) and (c) EUTMR, and Article 59(1)(b) EUTMR. The Cancellation Division (CD) dismissed the application in its entirety and the applicant appealed this decision. The Board of Appeal (BoA) dismissed the appeal as it cannot be generally stated that a mark lacks distinctiveness because of any of the following reasons: it consists of one or two letters; the letters ‘hp’ play a dominant role and are not descriptive or lacking in distinctiveness; the applicant did not prove that the contested mark was descriptive or lacking in distinctiveness at the time of registration. The applicant appealed to the General Court (GC) relying on three pleas in law: (i) infringement of Article 59(1)(a) EUTMR, read in conjunction with Article 7(1)(c) EUTMR; (ii) infringement of Article 59(1)(a) EUTMR, read in conjunction with Article 7(1)(b) EUTMR; and (iii) infringement of Article 59(1)(b) EUTMR. **On the second plea in law:** the contested mark is not descriptive of the goods and services it covers; the applicant’s general and unsupported argument seeking to call into question the BoA’s assessment, i.e. that the mark has a degree of distinctiveness allowing it to perform its function of indicating the commercial origins of the goods and services it covers, cannot be accepted; the BoA rightly found that the combination of the two letters, accompanied by figurative elements, is not commonly used or perceived simply as an indication lacking any distinctive character; the argument that the contested mark has no characteristic element,



or any memorable or eye-catching features capable of lending it a minimum degree of distinctiveness, should be rejected (para. 48). The contested mark has a minimum degree of distinctiveness and is capable of performing the essential function of a trade mark (para. 49).

♦[T-208/17](#); **HP**; *Senetic S.A. v EUIPO*; Judgment of 24 April 2018; EU:T:2018:216; Language of the case: EN. The intervener applied for an EUTM for the word mark **HP** for goods and services in Classes 2, 7, 9, 16, 35 to 38 and 40 to 42. The invalidity applicant filed an invalidity application on the basis of Article 59(1)(a) EUTMR read in conjunction with Article 7(1)(b) and (c) EUTMR. The Cancellation Division (CD) dismissed the invalidity application in its entirety and the applicant appealed this decision. The Board of Appeal (BoA) dismissed the appeal as it cannot be generally stated that a mark lacks distinctiveness because it consists of one or two letters. Further, the letters ‘hp’ play a dominant role and cannot be considered descriptive or lacking distinctiveness. The BoA found that the invalidity applicant had neither proved that the contested mark was descriptive, nor lacking distinctiveness at registration. The EUTM applicant filed an action relying on three pleas in law: (i) infringement of Article 59(1)(a) EUTMR read in conjunction with Article 7(1)(c) EUTMR; (ii) infringement of Article 59(1)(a) EUTMR, read in conjunction with Article 7(1)(b) EUTMR; and, (iii) infringement of Article 59(1)(b) EUTMR. **The second plea in law.** It is apparent that the contested mark is not descriptive of the goods and services. The BoA found that the combination of the two letters constituting the contested mark is not commonly used or perceived simply as an indication lacking any distinctive character (para. 46). The contested mark must be regarded as having a minimum degree of distinctiveness and capable of performing the essential function of a trade mark (para. 47).

♦♦[T-675/16](#), [T-676/16](#), [T-860/16](#); **mycard2go**; *Wirecard AG v EUIPO*; Judgment of 15 May 2018; EU:T:2018:267; Language of the case: DE

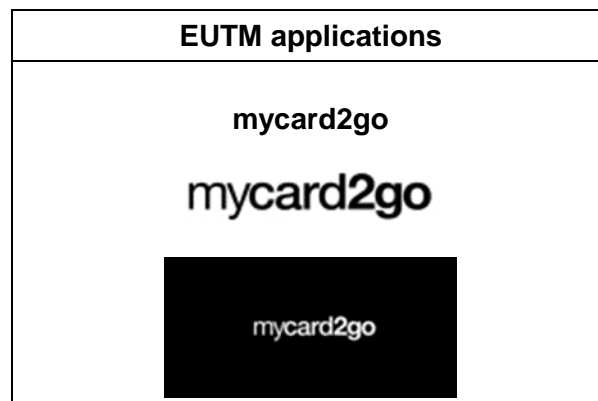

The applicant sought to register the word mark **mycard2go**, and the figurative marks above as EUTMs for goods and services in, inter alia, Classes 9 and 36. The Office refused the applications pursuant to Article 7(1)(b) and (c) EUTMR, as these were found to be, as a whole, descriptive. The applicant appealed and the Board of Appeal (BoA) dismissed the appeal, finding that the marks were descriptive and non-distinctive. The applicant appealed to the General Court (GC), relying on two pleas in law: (i) infringement of Article 7(1)(b) EUTMR and (ii) infringement of Article 7(1)(c) EUTMR. **Relevant public.** As the contested mark is composed of English words, the assessment must take into account the English-speaking public in the EU (paras 22 and 25). The goods and services target both the general public and also specialist consumers, such as businesses, with a relatively high level of attention. The services are of a financial nature falling within Class 36 and have a



certain economic importance to the consumer because they concern their economic and financial assets (para. 26). **Meaning of the mark.** ‘my’, ‘card’ and ‘go’ are basic English words. The number ‘2’ is often used in advertising as a synonym for ‘to’ (para. 34). Therefore, the sign will be understood immediately, without further considerations, as ‘my card to go’. This means that it is ideal for taking it away to pay for various goods and services. Furthermore, and contrary to what the applicant claims, it cannot be regarded as original or contradictory (paras 34-36). There is a sufficiently direct and specific link between the sign and the goods or services concerned from the point of view of the targeted public (para. 37). Actions were dismissed in cases T-676/16 and T-860/16. However, in T-675/16, the BoA’s decision lacked reasoning regarding the assessment of the link between the mark and the goods and services concerned. This is despite the other parallel decisions being contained in such reasoning (paras 44-45).

♦[T-413/17](#); **3D (fig.)**; *Karl Storz GmbH & Co. KG v EUIPO*; Judgment of 19 June 2018; EU:T:2018:356; Language of the case: EN

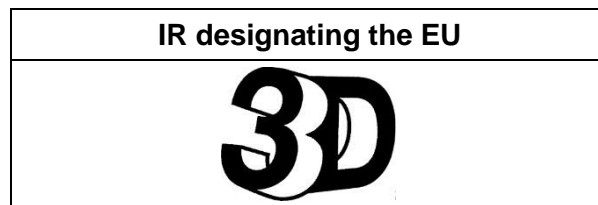

The applicant filed for an extension of the international registration (IR) for the figurative sign above for the goods in Classes 9, 10 and 16. The Office refused protection of the IR for these goods on the grounds of Article 7(1)(b) and (c) EUTMR. The applicant appealed the Office’s decision. The Board of Appeal (BoA) dismissed the applicant’s appeal. The applicant appealed to the General Court (GC) relying on two pleas in law: (i) infringement of Article 7(1)(c) EUTMR read in conjunction with Article 94(1) EUTMR and (ii) infringement of Article 7(1)(b) EUTMR. **Distinctiveness.** The grounds that allowed the BoA to find that the sign was devoid of distinctive character for those goods referred to as the eighth group are misconceived (para. 91). Indeed, the BoA has not explained the reasons why the sign at issue is devoid of distinctive character, other than those relating to descriptive character (para. 92). Even if the figurative elements of the sign at issue are not striking and do not render the verbal element ‘3D’ indiscernible, but rather strengthen it, that verbal element is not descriptive for the goods in group eight, and is therefore distinctive. Therefore, the sign at issue does have the minimum distinctive character for those goods not to be rejected under Article 7(1)(b) EUTMR (para. 93).

♦[C-488/16 P](#); **NEUSCHWANSTEIN**; *Bundesverband Souvenir — Geschenke — Ehrenpreise v EUIPO*; Judgment of 6 September 2018; EU:T:2018:673; Language of the case: DE. The EUTM proprietor registered the word mark **NEUSCHWANSTEIN** as an EUTM for goods and services in Classes 3, 8, 14 to 16, 18, 21, 25, 28, 30, 32 to 36, 38 and 44. An application for invalidity was filed pursuant to Article 59(1)(a) EUTMR in conjunction with Article 7(1)(b) and (c) EUTMR. The Cancellation Division (CD) dismissed the application for invalidity. This was because firstly, the contested mark did not consist of indications which might serve to indicate the geographical origin or other characteristics of the goods and services concerned. Secondly, it was distinctive for those goods and services, and thirdly, the invalidity applicant did not prove that the EUTM proprietor had acted in bad faith. The Board of Appeal (BoA) confirmed the CD’s decision and dismissed the appeal. The invalidity applicant appealed to the General Court (GC), relying on three pleas in law: (i) infringement of Article 7(1)(b) EUTMR (ii) infringement of Article 7(1)(c)





EUTMR, (iii) infringement of Article 59(1)(b) EUTMR. The GC rejected the three pleas of the invalidity applicant and dismissed the action in its entirety. The invalidity applicant appealed to the Court of Justice of the European Union (CJ). **Distinctiveness.** ‘Neuschwanstein’ means ‘new swan stone’. This word element constituting the contested mark, which is identical to the name of the castle, is a fanciful name which has no descriptive relationship with the goods and services marketed or offered and, consequently, the mere affixing of the mark on the items sold and the services offered enables those goods and services to be distinguished from other everyday consumer goods and services sold or provided in other commercial or tourist areas (para. 65). Furthermore, the mark enables the relevant public, because of the nature of its name, not only to refer to a visit to the castle, but also to distinguish the commercial origin of the relevant goods and services, so that it will conclude that all the designated goods and services were manufactured, marketed or supplied under the control of the Freistaat Bayern, which is the owner of the mark and the castle(para. 66).

♦[T-313/17](#); **FORM EINER FLASCHE (3D)**; *Wajos GmbH v EUIPO*; Judgment of 3 October 2018; EU:T:2018:638; Language of the case: DE

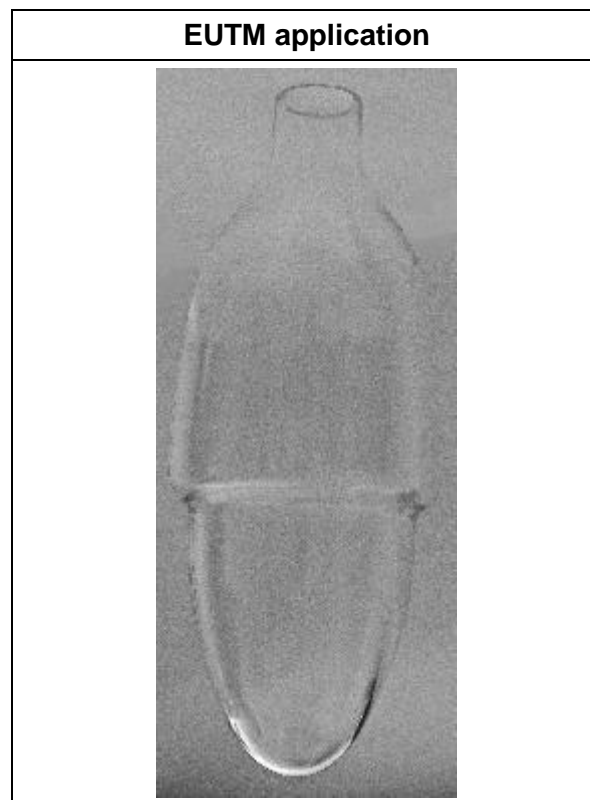

The applicant sought to register the three-dimensional mark above as an EUTM for goods in Classes 29, 30, 32 and 33. The Office refused to register the EUTM application pursuant to Article 7(1)(b) EUTMR and the applicant filed an appeal. The Board of Appeal (BoA) dismissed the appeal as it found that the mark was devoid of any distinctive character. The applicant filed an action with the General Court (GC), relying on a single plea in law: infringement of Article 7(1)(b) EUTMR. **Relevant public.** The goods concerned target the general public and customers with an increased level of attention. The wording of the list of goods includes very everyday foodstuffs (paras 17-18). Their eventual high price does not mean that the public will exhibit a particularly high degree of attention (para. 20).



**Significant departure from the norm used on the market.** The three-dimensional mark applied for is a transparent amphora-like container. The upper part is tapered into the mouth of a bottle with a glass lid. The lower part is narrower than the upper part and tapers to a rounded end. The upper part is separated from the lower, narrower part by a slight ridge, which not only constitutes a technical and functional feature, but also adds aesthetic value to the contested mark. Consumers are not accustomed to such an accentuated curved form in the middle of a bottle. The form departs significantly from classical amphoras, in particular as amphoras are not normally made of glass. The combination of elements comprising the contested mark is unique and not trivial, easily memorised by the relevant public (paras 34-35). Therefore, it acquires a particular appearance which, taking into account the overall aesthetic result, is capable of holding the attention of the public concerned and enabling that public, made aware of the shape of the packaging of the goods, to distinguish the goods covered from those with a different commercial origin (para. 36). Therefore, taken as a whole, it presents the required minimum distinctiveness for registrability (para. 39).

♦[T-93/16](#); **VANGUARD**; *Rheinmetall Waffe Munition GmbH v EUIPO*; Judgment of 10 October 2018; EU:T:2018:671; Language of the case: DE. The IR holder designated the EU for the word mark **VANGUARD** for *projectiles, namely grenades or firecrackers with blast-flash loads and also flashbang (stun) loads for irritation and/or disorientation purposes* in Class 13 and *advertising; distribution of advertising material* in Class 35. The Office refused to protect the mark pursuant to Article 7(1)(b) and (c) EUTMR. The IR holder filed an appeal, which the Board of Appeal (BoA) dismissed. It found that the relevant professional public would understand the term ‘vanguard’, when affixed to a weapon, as a descriptive message within the meaning of Article 7(1)(b) EUTMR, to the effect that the weapon was intended for use by the part of the armed forces on the front line, or by soldiers, police officers, etc., who occupy the leading position. Furthermore, the term ‘vanguard’ also refers to a group that is a leader in its field, and is thus laudatory and lacks distinctive character. The IR holder appealed to the General Court (GC), relying on two pleas in law: (i) infringement of Article 7(1)(b) EUTMR and (ii) infringement of Article 7(1)(c) EUTMR. **Lack of distinctive character.** After a very brief analysis, based solely on the general laudatory concept conveyed by the term ‘vanguard’, the BoA found that, regardless of its use in the fields in question, the sign **VANGUARD** was manifestly incapable of having distinctive character. It made this finding without verifying whether, for the relevant public and, in particular due to the very specific nature of the goods concerned, it was capable of designating the commercial origin of those goods (para. 62). The first plea in law thus prevails. Since the second plea is also well founded, the action must be granted in its entirety and the contested decision set aside.

[T-743/17](#); **CARACTÈRE**; *Bischoff GmbH v EUIPO*; Judgment of 12 December 2018; EU:T:2018:911; Language of the case: FR. The word mark **CARACTÈRE** was registered for goods and services in Classes 9, 14, 18, 24 and 35. An application for a declaration of invalidity was filed against the contested mark for all the abovementioned goods and services on the basis of Article 59(1)(a) EUTMR read in conjunction with Article 7(1)(b) and (c) EUTMR. The Cancellation Division (CD) granted the application for a declaration of invalidity for all of the goods in Class 9, with the exception of *mechanisms for prepaid devices* and *fire extinguishers*. Regarding the goods and services in the other classes, the CD rejected the application. The EUTM proprietor appealed, filing a declaration under Article 33(8) EUTMR for the goods in Classes 9, 14, 18 and 25, which was accepted by the Office. The invalidity applicant indicated that its application for a declaration of invalidity also concerned the goods for which protection had been extended. The Board of Appeal (BoA) rejected the appeal finding that the contested trade mark was sufficiently distinctive



to fulfil the function of a trade mark for the goods in question. The applicant filed an action with the General Court (GC), relying on two pleas in law: (i) infringement of Article 7(1)(c) EUTMR and (ii) infringement of Article 7(1)(b) EUTMR. (i) The BoA identified the French-speaking consumer of everyday consumer goods and services as the relevant public. This finding was confirmed (para. 28). The invalidity applicant argued that the contested mark pointed to the originality of certain goods. In the context of the definitions provided by the invalidity applicant, the element whose originality is underlined is systematically presented as having '*du caractère*' or as being '*de caractère*' (para. 30). However, the contested mark is composed of the term '*caractère*' and not of the expressions '*du caractère*' or '*de caractère*' (para. 31). The term '*caractère*' is a common term that can be used to refer to any characteristic or attribute specific to something (para. 32). In principle, the term '*caractère*' is followed by an adjective that may have a meliorative, depreciative or neutral meaning and may relate to all types of goods and services (para. 33). It is a common term without any particular meaning or connotation in relation to the goods and services covered. In other words, the term '*caractère*' is neutral and it is not sufficient to identify the goods or services to which it refers nor is it a characteristic or other attribute specific to those goods and services (para. 34). The mere fact that the term '*caractère*', associated with the preposition '*de*', may evoke the originality of the product or service to which it relates, is not sufficient to conclude that this would also be the case for the sign '*caractère*'. Indeed, even if the expression '*de caractère*' could point to the originality of a product, the term '*caractère*' is neutral and does not convey any positive qualities (paras 36-37). The BoA rightly considered that the invalidity applicant had not established the descriptive character of the contested trade mark within the meaning of Article 7(1)(c) EUTMR (para. 42). (ii) The contested trade mark is composed of the sole term '*caractère*', which is neutral and devoid of any positive connotation. There was no indication that the contested mark was perceived as a synonym of the expression '*de caractère*' (para. 53). The BoA rightly rejected the invalidity applicant's arguments based on the lack of distinctive character of the contested trade mark (para. 54).

### 3. **Outcome: Descriptive (Article 7(1)(c) EUTMR)**

**T-804/16; Dual Edge; LG Electronics, Inc. v EUIPO**; Judgment of 18 January 2018; EU:T:2018:8; Language of the case: EN. The applicant sought to register the word mark **Dual Edge** for goods in Class 9 (*smart phones; portable communications apparatus; monitors for computers; monitors for commercial purposes; audio components; apparatus for recording, transmission or reproduction of sound and images; application software; software for mobile phones; television receivers (TV sets); wearable smart phones; cases for mobile phones; stands for mobile phones; stylus for smart phones; portable mobile phone chargers; headphones; earphones; wireless headphones*). The EUIPO rejected the application for registration in part on the basis of Article 7(1)(b) and (c) and Article 7(2) EUTMR for the following goods: *smart phones; portable communications apparatus; monitors for computers; monitors for commercial purposes; apparatus for recording, transmission or reproduction of sound and images; television receivers (TV sets); wearable smart phones; cases for mobile phones; stands for mobile phones; stylus for smart phones*. The applicant filed a notice of appeal which was dismissed by the Board of Appeal (BoA) because the mark was found to be descriptive and consequently non-distinctive. The applicant raised two pleas in law: (i) infringement of Article 7(1)(b) EUTMR and (ii) infringement of Article 7(1)(c) EUTMR. **Descriptiveness.** The application's goods are intended for average English-speaking consumers, that are reasonably well informed, observant and circumspect (para. 23). The mark consists of the combination of two English words, DUAL which means 'relating to two, double' and EDGE which is 'the border, brim or



margin of a surface, object' according to the *Collins English Dictionary* (para. 27). The BoA did not expressly attribute a meaning to the expression 'dual edge', it analysed the descriptiveness of the expression and noted that no analysis was required in order to ascertain the possible meaning of that expression since it was merely a combination of two words (para. 28). The expression 'dual edge' will be immediately perceived by the relevant public as meaning that the goods are mobile phones and display apparatus with dual displays incorporated along the rims of the telephones or apparatus or goods used in connection with those devices and this is confirmed by examples of actual use on the market of expressions similar to the mark applied for, used for similar or identical goods (para. 31). A direct link would be made by the relevant public between the mark and the characteristics of the goods (para. 34). According to the Office, DUAL EDGE was used at the time of the application of registration to designate an innovative characteristic of screens and of mobile phone screens (para. 36). So there is a link between the mark applied for and the goods covered as it refers directly and specifically to a characteristic of some of the goods covered (namely, *mobile phones, portable communications apparatus, apparatus for recording, transmission or reproduction of sound and images, monitors for computers, monitors for commercial purposes and television receivers*) (para. 38). The expression DUAL EDGE will likely be recognised by the relevant public as a description of one of their characteristics, namely the fact that they have an integrated screen on two sides of the device (para. 39). Moreover, the examples of EU trade marks referred to in the application are irrelevant since they contain only one of the two words, DUAL or EDGE, together with another word element (para. 44). **Distinctiveness.** Since one ground of refusal is sufficient there is no need to examine this plea in law (para. 47).

**T-869/16; SWISSGEAR; Wenger SA v EUIPO;** Judgment of 23 January 2018; EU:T:2018:23; Language of the case: EN. The applicant sought to register the word mark **SWISSGEAR** for Classes 9, 12, 14, 16, 18, 20, 22 and 25. The intervener filed an application for a declaration that the contested mark was invalid for all the goods covered by that mark. The Cancellation Division (CD) rejected the application except for the goods in Class 14 (*watches of Swiss origin*). The intervener filed a notice of appeal seeking the annulment of CD's decision insofar as it had rejected the application for a declaration of invalidity. The applicant also brought an appeal against the decision insofar as it had upheld the application for a declaration of invalidity. The Board of Appeal (BoA) upheld the intervener's appeal and dismissed that of the applicant. The BoA focused its analysis on the general public in the Member States where English is an official language, who were considered to be well informed and reasonably observant and circumspect consumers for all the goods in question, except for the *vehicles and apparatus for locomotion by land, air or water* in Class 12, where consumers would display a higher level of attention. In accordance with Article 7(1)(c) EUTMR, the BoA found that the word 'gear' was descriptive with regard to all of the goods in question and that the word 'swiss' constituted an indication of geographical origin and of quality in light of the reputation of goods or services that come from Switzerland, and an evocation of that country's nature and tourist attractions and of the tourism-related activities that take place there. It was established that there was a link between the geographical indication and all of the goods in question. Moreover, in respect of Article 7(1)(b) EUTMR the BoA found that the lack of distinctive character of the sign **SWISSGEAR** arose out of its semantic content, the information that the sign conveyed as regards the geographical characteristic of the goods in question and the overlap between the respective scopes of the Article mentioned before. The applicant raised two pleas in law: (i) infringement of Article 7(1)(c) EUTMR and (ii) infringement of Article 7(1)(b) EUTMR. **Whether annexes 8, 9 and 10 are admissible.** Annex 9, which relates to the results of an internet image search carried out on the basis of the term 'swissgear', must be excluded as the results were not produced in the course of the administrative proceedings;



Annex 8, which relates to the results of an internet image search carried out on the basis of the term ‘gear’ should not be excluded, as the results were produced in the course of the proceedings; Annex 10, which consists of five extracts from the Office’s register of trade marks that relate to trade marks containing the term ‘swiss’, should not be excluded (paras 19-27). **On the first plea in law:** the contested mark consists of two English terms, namely ‘swiss’ and ‘gear’, both of which are, according to the contested decision, descriptive and the combination of which is itself regarded as descriptive (para. 38). At the time when registration of the contested mark was sought, the relevant public perceived the element ‘swiss’ in that mark as an indication relating to the origin of the goods in question (para. 43). In addition, the word ‘swiss’ was associated with notions of quality and robustness connected with the purpose of the goods in Classes 20 and 22 (para. 45). The element ‘swiss’ in the contested mark is descriptive with regard to all of the goods in question. The element ‘gear’ has a number of meanings, namely those of a toothed wheel that engages with another toothed wheel or with a rack in order to change the speed or direction of transmitted motion, personal equipment and accoutrements, belongings, equipment and supplies for a particular operation such as a sport, and up-to-date clothes and accessories, especially those bought by young people (para. 53). Moreover, all the categories of goods in question may be linked directly and specifically with one of the possible meanings of the word ‘gear’; namely, that of ‘equipment’ as regards the goods in question in Classes 9, 16 and 18, that of ‘gear’ as an ‘engine part’ or ‘cogwheel’ as regards the goods in Class 12, that of ‘accessory’ as regards the other goods in question in Class 12, and the goods in question in Classes 20 and 22, which correspond to accessories necessary for camping, and lastly that of ‘clothing’ as regards the goods at issue in Class 25 (para. 56). The fact that a word has a number of meanings does not make it vague. Moreover, the fact that the meaning of a word is broad does not have the effect of reducing its descriptiveness, but, on the contrary, of increasing it (paras 58-59). Therefore, the element ‘gear’ is descriptive (para. 60). The word mark **SWISSGEAR** is descriptive as each element is descriptive of characteristics of the goods in question (para. 62). **On the second plea in law:** as the mark applied for was descriptive and did not enable the consumer to determine the origin of the goods it was therefore devoid of any distinctive character (paras 73-77).

**T-866/16; billiger-mietwagen.de; SilverTours GmbH v EUIPO;** Judgment of 25 January 2018; EU:T:2018:32; Language of the case: DE. The applicant sought to register the word mark **billiger-mietwagen.de** as an EUTM for services in Classes 35, 38 and 39. The Office refused the registration of the EUTM application pursuant to Article 7(1)(b) and (c) EUTMR, as it was found to be devoid of distinctive character and descriptive. The applicant appealed and the Board of Appeal (BoA) dismissed the applicant’s appeal insofar as it found that the contested mark will be understood as a reference to an internet portal for motor vehicle hire with favourable conditions and therefore is descriptive. The applicant filed an action before the General Court (GC) relying on three plea(s) in law: (i) infringement of the first sentence of Article 95(1) EUTMR, (ii) infringement of Article 7(1)(c) EUTMR and (iii) infringement of Article 7(1)(b) EUTMR. **Relevant public.** The EUTM application is an expression composed of German words and, therefore the relevant public is the German-speaking public of the EU. The services partly target the general public (e.g. hire car customers) and partly target specialists. Furthermore, they primarily consist of services not used on a daily basis and, in some cases, ones which require considerable financial investments. As a result, the level of attention in relation to most of the services is increased (para. 37). **Meaning of the mark.** The word mark ‘billiger-mietwagen.de’ consists of three elements, ‘billiger’ [cheap], ‘mietwagen’ [hire car] and ‘.de’ (paras 16, 38). The combination of these is presented to the relevant public as the internet address of the domain: billiger-mietwagen.de. The component ‘.de’ is known as the German country code top-level



domain of a website and will therefore be immediately interpreted as related to the address of a German website or a website that is associated with Germany (paras 17, 38). The adjective 'billig', when preceded by the indefinite article 'ein' (an) or when not preceded by any article, has the form 'billiger'. Therefore, the expressions «ein billiger Mietwagen» or «billiger Mietwagen» are linguistically and grammatically correct in German (para. 23). **Direct link.** The relevant public will understand immediately and without further reflection that the sign describes the subject or purpose of the service provision, namely making a favourable offer for hiring a motor vehicle, as well as the nature and characteristics of the service and the way it is provided, namely that it takes place online via an internet portal (para. 42). **Distinctiveness.** Since one of the absolute grounds for refusal is met, there is no need to assess distinctiveness (para. 53).

**T-35/17; iGrill; Weber-Stephen Products LLC v EUIPO;** Judgment of 31 January 2018; EU:T:2018:46; Language of the case: EN. The international registration designating the European Union of the word mark **iGrill** was notified to the Office for registration for goods in Class 9. The Office refused to register the mark applied for pursuant to Article 7(1)(b) and (c) EUTMR, and the applicant appealed. The Board of Appeal (BoA) dismissed the appeal insofar as it found that the contested mark was descriptive: it stated that **iGrill** was a neologism composed of the element 'i' and the word 'Grill'. The letter 'i', as a prefix, referred to the word 'interactive', as well as to information technology, and the word 'grill' referred to a cooking device. Therefore, the relevant public will understand the term 'iGrill' as referring to an interactive grill or a grill which employs information technology. The applicant lodged an application for registration of the change of the proprietor of the international registration with WIPO and the new proprietor was Weber-Stephen Products LLC. The latter filed an action before the General Court (GC) relying on two pleas in law: (i) infringement of Article 7(1)(c) EUTMR and (ii) infringement of Article 7(1)(b) EUTMR. **Relevant public.** The relevant public is the English-speaking general and specialised public of the EU (para. 19). **Meaning of the mark.** The word 'grill' is a common word in English, which denotes a cooking device, whereas the letter 'i' can mean 'intelligent' or refer to information technology (para. 22). The contested mark will be seen as the mere juxtaposition of the two elements 'i' and 'grill' and not a neologism consisting of a single word which has no obvious meaning (para. 23). **Direct link and descriptiveness.** 'iGrill' may mean a grill having the characteristic of being intelligent and of making use of information technology. In addition, the goods have the characteristic of making grills intelligent by enabling them to make use of information technology in order to assist their users (para. 33). Therefore, as its meaning serves to designate the above characteristic, it is descriptive (para. 34). **The office's decision-making practice.** The descriptiveness of the contested mark is not counteracted by the fact that the Office interpreted the letter 'i' differently in previous decisions and allowed the registration of marks with the letter 'i' as a prefix, even though the goods and services of those marks are part of the information technology sector (para. 38). **Distinctiveness.** There is no need to examine distinctiveness, as there is already one ground that justifies refusal (para. 43).



**T-205/17; SECURE DATA SPACE (fig.); SSP Europe GmbH v EUIPO;** Judgment of 15 March 2018; EU:T:2018:150; Language of the case: DE



The EUTM applicant sought to register the figurative sign above for services in Classes 38 (*providing internet access for others; email services; data exchange services*) and 42 (*providing of memory space on the internet; providing of online storage; computer security services for secure internet access; computer system design; providing of an internet platform for exchanging data*). The Office refused to register the mark and the applicant filed a notice of appeal against the Office’s decision. The Board of Appeal (BoA) dismissed the appeal because it considered that the services covered were aimed at both the general public and the professional public, and noted that the level of attention varied from medium to high. It also considered that the word elements of the mark applied for, being ‘secure data space’, would describe the purpose of the services concerned. It added that the figurative element of the mark applied for would only reinforce the descriptive character of its word elements and concluded that the mark applied for was descriptive and devoid of distinctive character. The EUTM applicant filed an action before the General Court (GC) relying on two pleas in law: (i) infringement of Article 7(1)(c) EUTMR and (ii) infringement of Article 7(1)(b) EUTMR. **Descriptiveness:** the relevant public was the general public and a professional public, both English-speaking, with a level of attention that varied from medium to high (para. 15). The expression describes the intended purpose of the services offered, namely computer, internet, email and data exchange services, so it is descriptive of the services provided (para. 16). The combination of the three words ‘space’, ‘data’ and ‘secure’ can be understood as ‘secure data space’ (para. 27). So the word mark was descriptive of the services in question (para. 28). The sign indicates that the services provide a secure, virtual data space in which the consumer can store, save or retrieve data in a secure manner. The figurative element only further reinforces the descriptive character of the words, as the cloud and the two arrows pointing in opposite directions are typical symbols for data exchange and cloud computing. There is nothing unusual in the expression or the figurative elements. The connection between the services and the meaning of the sign is direct; no further reflection is needed to perceive this meaning (paras 33-36). **Distinctiveness.** Since one ground of refusal is sufficient, there is no need to go into this plea in law (paras 38-40).

♦**T-272/17; Dating Bracelet (fig.); Webgarden Szolgáltató és Kereskedelmi Kft v EUIPO;** Judgment of 20 March 2018; EU:T:2018:158; Language of the case: HU

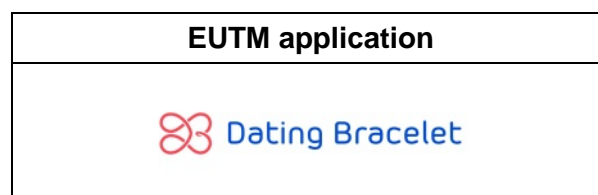

The applicant sought to register the figurative mark above as an EUTM for goods and



services in Classes 9, 41, 42 and 45. The Office refused the registration of the EUTM application pursuant to Article 7(1)(b) and (c) EUTMR. The EUTM applicant appealed and the Board of Appeal (BoA) dismissed the appeal. It found that the mark was descriptive and non-distinctive. The EUTM applicant filed an action before the General Court (GC) relying on three pleas in law: (i) infringement of Article 4 EUTMR, (ii) infringement of Article 7(1)(b) and (c) EUTMR and (iii) infringement of the principles of equal treatment and legal certainty. **Relevant public.** Since the word elements of the trade mark form an English expression, the relevant public is the English-speaking public of the EU (Ireland, Malta and the United Kingdom) (para. 31). Irrespective of the fact that some of the goods and services are directed at a specialised public, there is nothing to indicate that the specialised public would have a different perception of the mark than the general public (para. 36). **Meaning of the mark.** The composition 'Dating Bracelet' refers to a 'bracelet for dating' or a 'bracelet used for arranging dates' (para. 39). In particular, it has been proved that it designates in trade an existing electronic device worn around the wrist that runs software purported to assist in finding a partner (paras 43-45). **Descriptiveness.** For goods in Class 9, 'Dating Bracelet' indicates that it is a connected device worn around the wrist that contains IT and electronic components that through emitting and receiving electronic signals facilitates dating (para. 48). For services in Class 41, it indicates that the services in night clubs, discotheques and online forums target consumers wearing the dating bracelet (para. 49). For services in Class 42, it indicates that the services are closely connected to the operation of the IT components of the device, through which it enables its wearer to arrange dates or update information stored in the bracelets (para. 50). For services in Class 45, it indicates online social networking services and personal introduction services through use of the dating bracelet (para. 51). The figurative element depicting two intertwined hearts merely reinforces the meaning of the word elements (para. 57).

**T-354/17; ONCOTYPE DX GENOMIC PROSTATE SCORE; *Genomic Health, Inc. v EUIPO***; Judgment of 23 April 2018; EU:T:2018:212; Language of the case: EN. The EUTM applicant sought to register the word mark **ONCOTYPE DX GENOMIC PROSTATE SCORE** for services in Class 44, namely for *medical testing for diagnostic and treatment purposes in the field of cancer, and providing medical information to medical professionals in the form of reports in the field of cancer*. The Office objected to the application because it was descriptive and had no distinctive character according to Article 7(1)(c) and (b) EUTMR read in conjunction with Article 7(2) EUTMR. The applicant submitted its observations but the Office maintained the objections. The applicant appealed, and the Board of Appeal (BoA) dismissed the appeal in its entirety, finding that the word mark applied for was descriptive. The EUTM applicant appealed to the General Court (GC) relying on three pleas in law: (i) a breach of the general principles of equal treatment, good administration and legal certainty, (ii) infringement of Articles 7(1)(c) EUTMR and 7(2) EUTMR and (iii) infringement of Article 7(1)(b) EUTMR and 7(2) EUTMR. **Second plea in law.** The BoA examined the overall impression that the public concerned will have of the mark, after assessing the various constituent elements. The BoA found that the part of the relevant public comprising medical professionals would be capable of easily perceiving that the mark refers to services which can detect, diagnose and measure the genetic possibility of a prostate tumour. There is a direct link between the mark and the services, as it will immediately inform the relevant public of the nature and intended purpose of those services (para. 32). The BoA committed no error in finding that the neologism 'oncotype' was descriptive, since it considered it to be a word resulting from a combination of the prefix 'onco', which designates a tumour, and the word 'type', designating a group of things which have a particular common characteristic. The juxtaposition of which can be perceived, in the context of cancer-related services intended for professionals, as referring to a type of tumour (para. 33). The BoA did not rely exclusively on the definitions of the words which





make up the mark. In fact, the BoA's final analysis was based on the relevant public's perception of that mark (para. 35). An analysis, based on the definitions in the Collins English Dictionary and an online medical dictionary, and the perception of the mark as a whole by the relevant public, resulted in the BoA concluding that it was descriptive on the basis of Article 7(1)(c) EUTMR (para. 37). The word mark designates certain specific characteristics of the services, allowing the public concerned, or part of it, to perceive that it relates to services that detect, diagnose and measure the genetic possibility of a prostate tumour (para. 38). It follows that the BoA did not commit any error in finding that the mark could not be registered in accordance with Article 7(1)(c) EUTMR (para. 39). **Third plea in law.** Since one ground of refusal is sufficient there is no need to consider this plea in law (para. 43). **First plea in law.** The BoA held, on the basis of a thorough examination considering the perception of the relevant public, that the applicant's EUTM application was caught by the absolute grounds for refusal set out in Article 7(1) EUTMR (para. 50). On 15 March 2016, the same day as the application for the mark in question the appellant also filed for the EUTM **ONCOTYPE DX BREAST RECURRENCE SCORE** for services in Class 44. This trade mark was subsequently registered. However, this is not a situation in which the Office refused to register the mark **ONCOTYPE DX GENOMIC PROSTATE SCORE**, in the full knowledge that registration of a mark claiming to be similar was allowed. Rather, it is a situation in which, in subsequently registering the mark **ONCOTYPE DX BREAST RECURRENCE SCORE**, the Office did not consider that the similar EUTM application **ONCOTYPE DX GENOMIC PROSTATE SCORE** had been rejected (para. 52).

♦[T-213/17](#); **ROMANTIK**; *Romantik Hotels and Restaurants AG v EUIPO*; Judgment of 25 April 2018; EU:T:2018:25; Language of the case: DE. The EUTM proprietor was granted the registration of the word mark **ROMANTIK** as an EUTM for services in Classes 39 and 43. An application for invalidity was filed pursuant to Article 7(1)(a) to (d) and (g) EUTMR in conjunction with Article 59(1)(b) EUTMR. The Cancellation Division (CD) partly upheld the application for invalidity. The Board of Appeal (BoA) dismissed the EUTM proprietor's appeal. It found that not only the German-speaking public, but also that in Ireland, the Netherlands, Sweden and the United Kingdom would perceive the word 'romantik' as a laudatory and a descriptive message in relation to the services. It also found that the EUTM proprietor had not proved that the word had acquired distinctiveness through the use made of it. The proprietor appealed to the General Court (GC) relying on two plea(s) in law: (i) the mark is endowed with the minimum distinctive character required, and (ii) the mark has acquired distinctive character through the use made of it in the marketplace. **Descriptiveness.** The GC emphasised the fact that though 'romantik' is a noun and not an adjective in German, this is not sufficient to conclude that it lacks descriptive character in relation to the services at issue since incorrect grammatical structures can be descriptive (para. 35). The mark will be perceived as an adjective in languages other than German (para. 36).



♦[T-220/17](#); **100% PFALZ (fig.)**; *Pfalzmarkt für Obst und Gemüse eG v EUIPO*; Judgment of 26 April 2018; EU:T:2018:229; Language of the case: DE

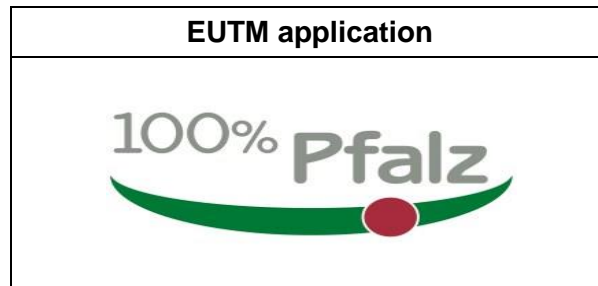

The applicant sought to register the figurative mark above as an EUTM for goods and services in Classes 31 (*fresh fruits and vegetables*) and 35 (*retail and wholesale services of fruits and vegetables*). The Office refused the registration of the mark according to Article 7(1)(b) and (c) EUTMR. An appeal was filed against the Office's decision and the Board of Appeal (BoA) upheld the appeal, declaring that the application was descriptive and non-distinctive. The applicant appealed to the General Court (GC), relying on three pleas in law: (i) infringement of Article 7(1)(c) EUTMR, (ii) infringement of Article 7(1)(b) EUTMR and (iii) Article 94 EUTMR. **Descriptiveness.** The applicant did not contest that the word elements will be understood as a description of the goods and services' geographical origin (para. 27). The figurative elements do not render the mark non-descriptive. The green figurative element is a simple and elongated shape situated below the word elements. It has a decorative character, emphasising and highlighting these letters. The red figurative element is integrated in the green figurative element and is decorative (para. 30). The BoA found that the figurative elements, regarding their form and position, do not divert the relevant public from the descriptive message conveyed by the word elements (para. 31). This result is not affected by whether the figurative element is distinctive or not or that it has been accepted as an EUTM (para. 32). **Distinctiveness.** As the sign will be refused due to its descriptive character (Article 7(1)(c) EUTMR) there is no need to examine this plea (para. 36).

[T-428/17](#); **ALPINEWELTEN Die Bergführer (fig.)**; *Alpine Welten Bergführer GmbH & Co. KG v EUIPO*; Judgment of 2 May 2018; EU:T:2018:240; Language of the case: DE



The applicant sought to register the figurative mark above as an EUTM for goods and services in Classes 16, 25, 39 and 41. The Office refused the registration for all the goods and services for which protection was sought, with the exception of the goods in Class 25. Pursuant to Article 7(1)(b) and (c) EUTMR, the mark was found to be descriptive and



devoid of any distinctive character. The Board of Appeal (BoA) partly upheld the applicant's appeal insofar as the application for *bookbinding material; adhesives for stationery or household purposes; artists' materials; brushes; printers' types; printing blocks; pens [stationery]; cases for stationery; paper articles and stationery* in Class 16 had been refused. It found, first, that the relevant public, consisting of German-speaking average and specialised consumers, would directly understand the terms 'ALPINEWELTEN' and 'Die Bergführer' as the description of an offer of alpine goods and services or of guided tours in the mountains, while the graphic elements simply served the purpose of underlining those verbal messages; and second, that the relevant public would perceive the mark as a promotional statement describing a basic characteristic of the goods and the services and not as an indication of their commercial origin. The applicant appealed to the General Court (GC), relying on two pleas in law: (i) infringement of Article 7(1)(b) EUTMR and, (ii) infringement of Article 7(1)(c) EUTMR. **Descriptiveness.** The BoA correctly identified the relevant public (paras 31-32). The mark applied for is a complex mark consisting of two verbal elements in German plus two figurative elements. The terms **ALPINEWELTEN** ('Alpine worlds') and **Die Bergführer** ('the mountain guides') are made up of basic German words and will therefore be directly understood by the relevant consumers without further reflection (paras 35-36). There are also two figurative parts: a green rectangle where the term **Die Bergführer** is contained, and a triangle on the upper part of the mark. The colour green evokes nature and the triangle, in relation to the verbal elements, will be readily perceived as a mountain. The figurative elements therefore respectively serve to frame and to underline the verbal messages. Therefore, it was concluded that the dominant parts of the complex mark are its verbal elements (paras 38-39). The relevant consumers will immediately see in the mark nothing but the description of an offer of goods and services in the alpine sector including guided tours in the mountains (para. 37). **The goods and services.** With regard to some of the goods in Class 16, namely those belonging to the category of printed matter, the relevant public will immediately understand that those goods are related to the Alps or guided tours in the mountains or that they relate to the organisation of such tours. As regards the advertising and promotional material, also in Class 16, consumers will understand that it is used by organisations to promote their services in their respective fields and, here, in relation to the Alps (para. 41). With respect to the services in Class 39, the relevant consumer will immediately understand that they are services provided in the alpine or mountain management sector, since part of the services in that class concern mountain guides and the remaining services are specific to excursions, trips and guided visits in the mountains (para. 42). Likewise, with regard to the services of Class 41, the mark applied for informs the relevant public that they relate to leisure activities, education, training, entertainment, sporting and cultural activities in the Alps and that guided mountain tours are involved (para. 43). The mark applied for thus describes the kind, destination and purpose of the goods and services. Therefore, the relevant public, when encountering the mark applied for in relation to these goods and services, will perceive the mark directly and without further reflection as providing descriptive information about them, rather than indicating their origin (para. 44). **Distinctive character.** Since the mark cannot be registered because one of the absolute grounds for refusal applies, namely descriptiveness, there is no need to examine the second plea in law concerning lack of distinctive character (paras 66-67).

♦[T-419/17](#); **VSL#3**; *Mendes SA v EUIPO*; Judgment of 18 May 2018; EU:T:2018:282; Language of the case: IT. The EUTM proprietor obtained registration of the word mark **VSL#3** as an EUTM for goods in Class 5. An application for revocation was filed pursuant to Article 58(1)(b) and (c) EUTMR. The Cancellation Division (CD) dismissed the application for revocation. The Board of Appeal (BoA) dismissed the revocation applicant's appeal. It found that the revocation applicant had neither provided sufficient evidence to



demonstrate that the sign had become the common name in trade of the goods for which it was registered, nor did it prove that the sign was liable to mislead the public concerning the nature or quality of the goods. The revocation applicant filed an action before the General Court (GC) relying on two pleas in law: infringement of Article 58(1)(b) and (c) EUTMR. **Relevant public.** The relevant circles for probiotic preparation for treating gastrointestinal disorders marketed under the contested mark include, in addition to pharmacists and doctors, the end consumers, given that the product does not require a medical prescription. The scientific community is not part of the relevant circles, playing no role in the communication process between the vendor and the purchaser (para. 40). **Descriptive element.** It was not proved that ‘VSL’ should be understood as being the acronym of ‘Very Safe Lactobacilli’ by the relevant circles, nor that the contested mark has become the common name in trade for the product. Therefore, the contested mark does not convey a clear message concerning the product or its characteristics (para. 61).

♦[T-314/17](#); **MEZZA**; *Nosio SpA v EUIPO*; Judgment of 31 May 2018; EU:T:2018:315; Language of the case: IT. The applicant sought to register the word mark **MEZZA** as an EUTM for *alcoholic beverages, in particular wines and sparkling wines* in Class 33. The Office refused to register the mark on the grounds of Article 7(1)(b) EUTMR and Article 7(1)(c) EUTMR. Before the Board of Appeal (BoA) the applicant requested to restrict the list of goods to *alcoholic beverages, in particular wines and sparkling wines, contained in bottles and/or containers with a capacity greater than or less than 37.5 cl*. The BoA dismissed the applicant’s appeal. Firstly, it found that the restriction of the list of goods was inadmissible; secondly, that the mark was devoid of distinctive character and that it was descriptive for the goods in question. The applicant appealed to the General Court (GC), relying on four pleas in law: (i) infringement of Article 49(1) EUTMR, (ii) infringement of Article 94 EUTMR, (iii) infringement of Article 7(1)(b) EUTMR and (iv) infringement of Article 7(1)(c) EUTMR. **Statement of reasons.** Since all the goods are alcoholic beverages and consumers consider the bottles as mere packaging in which the goods are contained, there is a sufficiently direct and concrete link between the goods to allow the applicability on common grounds of the contested decision (para. 22). **Descriptive element.** Even assuming that there is currently no commercial 37.5 cl bottle format for certain specific types of alcoholic beverages, such as liqueurs, spirits or bitters, these goods could be marketed in bottles of this size in the future, which is sufficient for a refusal of registration of the mark for being descriptive (para. 55).

[C-32/17 P](#); **PARKWAY (BILDMARKE)**; *Apcoa Parking Holdings GmbH v EUIPO*; Judgment of 6 June 2018; EU:T:2018:396; Language of the case: DE



The applicant sought to register two marks, the word mark **PARKWAY** and the figurative



mark above, as EUTMs for the services in Classes 35, 36, 39, 42 and 45. The Office refused the applications pursuant to Article 7(1)(b) and (c) EUTMR and Article 7(2) EUTMR, finding that they are descriptive and devoid of distinctive character. The applicant appealed against the Office's decision and requested a limitation of the marks' services. The Board of Appeal (BoA) dismissed the appeal, finding that the mark was descriptive and non-distinctive. The BoA considered that these signs could designate the characteristics of the services concerned and that the figurative mark's graphic configuration did not confer distinctive character on the sign. Therefore, the BoA confirmed the Office's decisions based on Article 7(1)(b) and (c) EUTMR. The applicant appealed to the General Court (GC), relying on four pleas in law: (i) procedural defect, (ii) infringement of Article 7(1)(c) EUTMR, (iii) distortion of the facts, and (iv) infringement of the unitary character of an EUTM. **First plea in law.** The GC considered that it was sufficiently informed by the submitted documents to decide the appeal and reject it as manifestly lacking any foundation in law (para. 23). **Second plea in law.** The GC held that while the term was added to the stations' proper names, it was not fanciful. Rather, this confirmed the descriptive use of the latter regarding the stations offer for parking (para. 35). The GC, in line with the Office and the BoA, cited examples of the term's use, namely 'East Midlands Parkway', 'Bristol Parkway', 'Southampton Parkway', 'Warwick Parkway', 'Liverpool Parkway', and 'Stratford-upon-Avon Parkway'. This confirms that, particularly in the United Kingdom, the term refers to station parking (para. 36). The GC held that neither the annex nor the other annexed documents covered the figurative mark's origin or the meaning of its logo. As the applicant's arguments did not identify the annex that they referred to, the GC could not exercise its review powers (para. 39). Then the GC assessed the figurative mark, namely by the way the colours in 'park' and 'way' were written, and the representation of the two arrows using the same colours. Lastly, the GC followed the BoA's finding that the figurative sign was limited to the verbal element 'parkway' through a simple graphic representation (para. 41). **Third plea in law.** The GC found that, according to the definitions of the Oxford Dictionary and the Oxford English Dictionary, 'parkway' means a railway station with ample parking space (para. 50). The GC found that it could not be criticised for misrepresenting the definition of 'parkway' as it is precisely the same definition used by the applicant (para. 51). **Fourth plea in law.** According to well-established case-law, the EU's trade mark system is an autonomous system that is independent of any national system. Therefore, the registration of an EUTM does not replace national registration in one or more Member States. The EU's trade mark regime coexists with existing systems in all Member States (para. 59).

[T-375/17](#); **BLUE**; *Kludia Patricia Fenyves v EUIPO*; Judgment of 12 June 2018; EU:T:2018:340; Language of the case: EN



The EUTM applicant sought to register the figurative sign above for goods and services in Classes 32 (*soft drinks; non-alcoholic beverages*), 35 (*advertising*) and 41 (*entertainment services, organising events for entertainment purposes, organisation of shows, music concerts*). The Office rejected the application on the basis of Article 7(1)(b) and (c) EUTMR, read in conjunction with Article 7(2) EUTMR, for the goods in Class 32. The applicant



appealed the decision and limited the list of goods in Class 32 to *soft drinks and non-alcoholic beverages, with the exception of energy drinks and isotonic sports drinks*. The Board of Appeal (BoA) dismissed the appeal, finding that the mark was descriptive and non-distinctive. The EUTM applicant appealed to the General Court (GC), relying on two pleas in law: (i) infringement of Article 7(1)(c) EUTMR, read in conjunction with Article 7(2) EUTMR, and (ii) infringement of Article 7(1)(b) EUTMR. **Relevant public.** As the mark is an English word, the relevant public is the general public in the English-speaking territories of the European Union. The level of attention of the relevant public is that of the average consumer, reasonably well informed, observant and circumspect (paras 18 and 20). **Descriptiveness.** The word ‘blue’ will naturally be understood by the English-speaking public of the European Union, immediately and without further thought, as referring to the colour blue (para. 30). There are many examples of blue-coloured drinks, and consequently that colour may reasonably be perceived as a significant characteristic of the goods in question, that is likely to be an important factor in consumer choice (para. 32). The word ‘blue’ is descriptive as a reference to the colour blue refers to the visual aspect of the goods in Class 32 of the mark (para. 33). The figurative elements of the mark — the typeface, colours and the diagonal position — do not make the mark particularly complex or offset or modify the descriptive character of the word in relation to the goods. The mark’s graphic representation is not sufficient to distract the relevant public from the descriptive message conveyed by the word (paras 35 to 37). Consequently, the contested mark is descriptive for soft drinks and alcohol-free beverages (para. 43). **Distinctiveness.** The sign was found descriptive within the meaning of Article 7(1)(c) EUTMR. Since that ground alone justifies the refusal of the contested mark, there is no need to examine the alleged breach of Article 7(1)(b) EUTMR (para. 46).

♦[T-78/17](#); **JUMBO**; *Jumbo Africa, S.L. v EUIPO*; Judgment of 26 June 2018; EU:T:2018:383; Language of the case: ES. The EUTM proprietor registered the word mark **JUMBO** as an EUTM for goods in Classes 29 and 30. An application for invalidity was filed pursuant to Article 59(1)(a) EUTMR in conjunction with Article 7(1)(b) and (c) EUTMR. The Cancellation Division (CD) upheld the invalidity application insofar as it found that the term ‘jumbo’ was descriptive of the goods covered, at least for the English-speaking public of the EU, and that insufficient proof had been adduced regarding the distinctiveness acquired by use. The EUTM proprietor appealed. The Board of Appeal (BoA) dismissed the appeal. It found that the expression ‘jumbo’ was a direct and obvious reference to the quantity and nature of the relevant foodstuffs, and there was nothing about the mark to suggest that it was unusual or might have its own meaning. Furthermore, the EUTM proprietor had neither claimed nor provided evidence that the trade mark applied for had acquired distinctiveness or had even been used in a substantial part of the EU where English was understood. The EUTM proprietor appealed to the General Court (GC), relying on two pleas in law: (i) infringement of Article 7(1)(b) EUTMR in conjunction with Article 59(1)(a) EUTMR and (ii) infringement of Article 7(3) EUTMR in conjunction with Article 59(2) EUTMR. **Relevant public.** Since the word ‘jumbo’ is a common word, in particular in English, the relevant public is the English-speaking public within the EU, which contains, at the very least, consumers from Ireland, Cyprus, Malta and the United Kingdom (para. 31). The relevant public is not solely EU consumers of African origin, since nothing in the wording of the EUTM application suggests that the goods are intended for African immigrants in Europe. The general terms used by the EUTM proprietor suggest that the goods are intended for the usual, average consumer of the food products concerned (paras 32-33). Therefore, the goods covered are directed at the general public with an average level of attention, deemed to be reasonably well informed, observant and circumspect (para. 30). **Meaning of the mark and descriptiveness.** The English word ‘jumbo’ is used informally to mean ‘very large’. Since these goods are foodstuffs which can be sold in different quantities, the



expression ‘jumbo’ is very likely to be understood as a reference to the size of the product, which is larger than standard. Therefore, it is a direct and obvious reference to the size or quantity of the relevant foodstuffs (para. 35).

[T-402/17](#) and [T-403/17](#) (joined cases); **Vienna House**; *Vienna International Hotelmanagement AG v EUIPO*; Judgment of 3 July 2018; EU:T:2018:401; Language of the case: DE



The applicant sought to register the figurative mark above and the word mark **VIENNA HOUSE** as EUTMs for services in Classes 39, 41 and 43. The Office refused the registration of the EUTM application pursuant to Article 7(1)(b) EUTMR and Article 7(1)(c) EUTMR regarding all services in Class 43 and certain services in Class 39. The Board of Appeal (BoA) dismissed both of the applicant’s appeals, since it found that the marks were descriptive and devoid of distinctiveness. The applicant filed two actions before the General Court (GC) relying on two pleas in law: (i) infringement of Article 7(1)(c) EUTMR and (ii) infringement of Article 7(1)(b) EUTMR. **Relevant public.** The relevant public is the English-speaking average consumer of the EU (para. 13). **Meaning of the mark.** The targeted average consumer will perceive the word combination **VIENNA HOUSE**, as a grammatically correct combination meaning a Viennese house. A reference can be made to a typical Viennese style in the hotel and catering industry, embodied, for example, by Viennese coffee houses. It appears unlikely that, when faced with an accommodation establishment designated **VIENNA HOUSE**, a consumer will assume that the establishment in question had no specific atmosphere whatsoever and/or an ambience completely unrelated to Vienna (paras 29-30). **Descriptiveness.** The mark **VIENNA HOUSE** describes the following: (a) that what is involved is a hotel, restaurant or coffee house designed in the typical Viennese style, which may also be located anywhere in the world, but which is distinguished by certain objective characteristics that cause consumers to specifically search out that hotel or café owing to its particular atmosphere (*arranging temporary accommodation or arranging accommodation in hotels, boarding houses and holiday homes; hotels*); (b) that what is involved is services related to a trip to such a hotel, restaurant or coffee house , or services providing appropriate information required in preparation for such a trip (*providing of travel information*); (c) that permanent facilities are also to be found on camping sites, for example, with catering and in the form of a ‘house’, and that not just tents and caravans are to be taken into account, with the result that the mark **VIENNA HOUSE** also applies to the services *arranging temporary accommodation or arranging accommodation in camping sites* (para. 31). Moreover, the graphic elements of the figurative mark are limited to the design of the letters in red standard script in the shape of an arch raised in the middle. These are extremely simple effects that do not offer a distinctive character and are not enough to rule out descriptiveness (para. 32). Therefore, the contested marks are descriptive (para. 48). Since the absolute ground of descriptiveness is met, there is no need to assess lack of distinctiveness (para. 52).

[T-180/17](#); **EM**; *EM Research Organization, Inc. v EUIPO*; Judgment of 25 September 2018; EU:T:2018:591; Language of the case: EN. The IR holder of the word mark **EM** for goods in Classes 1 and 31 designated the EU. An invalidity application was filed pursuant to



Article 59(1)(a) EUTMR in conjunction with Article 7(1)(b) to (d) EUTMR. The Cancellation Division (CD) upheld the invalidity application. The IR holder appealed. The Board of Appeal (BoA) dismissed the appeal finding that at the date on which the EU was designated, the contested mark was capable of being understood by the relevant public as a descriptive indication for the goods at issue or that there existed, at that date, definite and specific grounds for it to be reasonable to assume that such an association would be established in the future. In particular, the relevant English- and German-speaking public would understand the contested mark as an abbreviation for ‘effective microorganisms’ or ‘effektive mikroorganismem’, respectively, therefore as a descriptive indication of the goods at issue. The mark was furthermore devoid of any distinctive character. The proprietor filed an action before the General Court (GC), relying on two pleas in law: (i) infringement of Articles 182 EUTMR and Article 64 EUTMR read in conjunction with Article 7(1)(c) EUTMR and (ii) infringement of Article 182 EUTMR, Article 71(1) EUTMR and Article 64(5) EUTMR read in conjunction with Article 7(1)(b) EUTMR. **Relevant public.** Having regard to their nature and intended use, the *plant growth regulating and plant growth stimulating and enhancing preparations; soil conditioners; organic fertilizers; fertilizers and compost* in Class 1, which are essentially chemical products for agricultural and horticultural use, and the *agricultural and horticultural products not included in other classes, and foodstuffs for animals, including additives for foodstuffs for animals* in Class 31, which are essentially goods for agricultural and horticultural use and foodstuffs for animals, target members of the general public with an interest in gardening or who own pets or other animals and professionals (paras 40-44). **Descriptiveness.** From the evidence produced by the invalidity applicants, it is apparent that the abbreviation EM was already used to designate the expression ‘effective microorganisms’ (para. 55) and that the use of effective microorganisms was already widespread in the relevant fields on the date upon which the EU was designated (para. 58). In order to determine the descriptive character of the contested mark, the BoA did not rely solely on the statements produced by the invalidity applicants but considered them to corroborate the information from all the documents submitted (para. 62). Even though a large part of the evidence produced by the invalidity applicants is dated after the relevant date or is undated, it is nevertheless possible to gauge the relevant public’s perception of the abbreviation EM and the expression ‘effective microorganisms’ prior to the date at which the EU was designated. Furthermore, as a large part of the evidence is dated prior to the relevant dates, this in itself suffices to establish the descriptive character of the contested mark (paras 74-75). The applicant has not submitted any document to disprove the information on the meaning of M taken from internet sites such as Wikipedia and Acronym Finder — the reliability of which cannot be called into question by the mere fact that users have the possibility of adding new entries (paras 77-78). **Distinctiveness.** Since it is sufficient that one of the absolute grounds for refusal applies for the sign at issue not to be registrable, the examination under Article 7(1)(b) EUTMR is futile (paras 90-91).

**T-825/17; LIGHTBOUNCE; Carbon System Verwaltungs GmbH v EUIPO;** Judgment of 27 September 2018; EU:T:2018:615; Language of the case: DE. The applicant sought to register the word mark **LIGHTBOUNCE** as an EUTM for goods and services in Classes 11, 35 and 41. The Office refused to register the EUTM application pursuant to Article 7(1)(b) and (c) EUTMR, as it was descriptive and devoid of distinctive character. The applicant appealed. The Board of Appeal (BoA) dismissed the appeal and endorsed the Office’s findings. The applicant filed an action before the General Court (GC), relying on two pleas in law: (i) infringement of Article 7(1)(c) EUTMR and (ii) infringement of Article 7(1)(b) EUTMR. **(i) Relevant public.** The goods and services are specialised ones mainly intended for professionals in the field of photography whose degree of attention is high. Since the contested mark **LIGHTBOUNCE** consists of English words, the relevant public consists of





English-speaking consumers within the EU (para. 31). **Meaning of the sign.** The combination of the two words ‘light’ and ‘bounce’ will be understood to mean ‘light reflection’. The word components of the contested mark are joined together in a grammatically correct and syntactically normal manner, without presenting any perceptible difference from the construction of an expression intended to convey the same message (para. 33). **Direct link between the meaning of the mark and the characteristics of the goods.** The goods in Class 11 can all be used for photographic purposes and are employed to reflect light (para. 36). Regarding the services in Classes 35 and 41, the consumer will understand the expression as an indication that the services relate to providing technical support in connection with the reflection of light for photographic purposes or have light reflection in photography as their object (para. 38). Therefore, the trade mark conveys obvious and direct information about the nature and characteristics of the goods and services, with no mental effort required on the part of relevant consumers. Therefore, the applicant’s argument that three stages of effort are needed to attribute a meaning to the sign can only be refuted (para. 39). **Scope of proceedings.** Even if the Office erred in not taking into account the supplementary observations of the applicant — submitted out of time — regarding the USPTO’s decision on the registration of the contested trade mark in the United States (US), the Office is not bound by a decision given in a third country regarding registrability as a national mark. Registrations made in third countries are, therefore, only one factor which may be taken into consideration, without being given decisive weight, even when such a decision is adopted in a country belonging to the linguistic area in which the word mark originates (paras 43-44). (ii) It is sufficient that one of the absolute grounds for refusal listed applies for a sign not to be registrable as an EU trade mark (para. 48). Furthermore, a word mark which is descriptive of characteristics of the goods and services is, by any account, necessarily devoid of any distinctive character in relation to those same goods or services (para. 49).

[T-736/17](#); **FLEXCUT**; *Lincoln Global, Inc. v EUIPO*; Judgment of 4 October 2018; EU:T:2018:646; Language of the case: EN. The applicant sought to register the word mark **FLEXCUT** as an EUTM for goods in Classes 7 and 9. The Office refused to register the EUTM application pursuant to Article 7(1)(b) and (c) and Article 7(2) EUTMR, as it was descriptive and devoid of distinctive character. The applicant filed an appeal. The Board of Appeal (BoA) dismissed the appeal as it found that the mark applied for was descriptive and devoid of any distinctive character. The applicant filed an action with the General Court (GC), relying on two pleas in law: (i) infringement of Article 7(1)(c) EUTMR and (ii) infringement of Article 7(1)(b) EUTMR. The application’s goods refer to machinery and highly specialised tools which target a specialist professional public. The relevant consumer was deemed to be reasonably well informed and reasonably observant and circumspect (para. 21). The BoA found that since the mark applied for consisted of elements in English, the existence of absolute grounds for refusal had to be examined with regard to English-speaking consumers within the European Union and at least consumers in Ireland, Malta and the United Kingdom (para. 22). The mark applied for consists of two elements, namely ‘flex’, an abbreviation of the term ‘flexible’, and ‘cut’, an English word. The target public is able to understand the meaning of the words ‘flex’ and ‘cut’ (paras 27, 29). The combination of the words ‘flex’ and ‘cut’ follows the rule of English usage by which the adjective precedes the noun (para. 30). The term ‘flexcut’ has a clear and unambiguous meaning in the field to which the trade mark application relates, namely ‘flexible cut’. The sign in question will be understood as containing direct information on the quality or characteristic of the goods concerned (para. 32). The simple combination of the words ‘flex’ and ‘cut’ is itself also descriptive of the quality and the characteristics of those goods and is merely a simple description of the functions of the goods in question (para. 34). Since the word ‘flexcut’ will enable the public to understand immediately that that term refers to a quality or



characteristic of those goods, namely to enable a 'flexible cut', the BoA did not err in holding that the ground of refusal under Article 7(1)(c) EUTMR was applicable (para. 39). The sign is descriptive of the goods and services concerned for the purposes of Article 7(1)(c) EUTMR because that provision pursues an aim in the public interest, which requires that such signs or indications may be freely used by all (para. 42). The BoA carried out a full and specific examination of the mark applied for before refusing to register it (para. 50). On the applicant's argument that it registered the trade mark FLEXCUT in the United States for identical goods, without any objection being raised in that regard, the EU trade mark regime is an autonomous system with its own set of objectives and rules peculiar to it; it is self-sufficient and applies independently of any national system (para. 51). Given all of the above, the first plea must be rejected (para. 52). Since it is sufficient that one of the absolute grounds for refusal applies for the signs to be ineligible for registration as an EU trade mark, there is no need to rule on the second plea (paras 53-54).

**T-644/17; Sustainable; DNV GL AS, v EUIPO;** Judgment of 16 October 2018; EU:T:2018:684; Language of the case: EN. The applicant sought to register the word mark **Sustainable** as an EUTM for goods and services in Classes 9, 35 and 42. The Office refused to register the EUTM application pursuant to Article 7(1)(b) and (c) EUTMR for all the services in Class 35 and the services in Class 42 except *development of computer software application solutions*. The applicant filed an appeal. The Board of Appeal (BoA) dismissed the appeal finding that, since the services for which registration had been refused were, in essence, sustainable services aimed at reducing negative effects on the environment, the mark applied for was descriptive of the services at issue in Classes 35 and 42 and, as such, was necessarily devoid of distinctive character. The applicant filed an action before the General Court (GC), relying on two pleas in law: (i) infringement of Article 7(1)(c) EUTMR and (ii) infringement of Article 7(1)(b) EUTMR. **Descriptiveness.** The relevant public is made up of the English-speaking general public and professionals (undisputed) (paras 19-20). The sign **Sustainable**, notwithstanding its misspelling, will be understood by the relevant public as meaning the same as the English adjective of which the sign in question essentially consists, namely 'sustainable'. The simple addition of a graphic element at the end of the word, whether it is perceived as a number, a letter of the alphabet, or as a lexical mistake, is not going to affect the perception of the consumer (paras 27-28). The services of *providing consumer product information; providing consumer product information relating to food or drink products; providing information and advice to consumers regarding the selection of products and items to be purchased; providing advice relating to the analysis of consumer buying habits*, in Class 35, may, in the mind of the public concerned, aim to encourage a responsible use of the goods regarding the natural environment in which that public lives. The same is true of the services involving providing advice on the analysis of consumer buying habits, also aimed at promoting, as a whole, conduct that favours sustainable development and that is environmentally conscious (para. 32). Next, the service of *compilation of environmental information into computer databases*, in Class 35 and the services *scientific analysis of consumer habits; research in the field of environmental conservation; technical consultancy in the field of environmental science; technical consultancy, namely providing technological information about environmentally conscious and green innovations; development of computer software application solutions; testing of services for the certification of quality and environmental standards; design and development of software for evaluation and calculation of environment data; compilation of environmental information; compilation of information relating to environmental conditions* in Class 42, expressly concern the environment and, precisely because of that intended purpose, they can only be seen in the context of providing advice and promoting public awareness on environmental and ecological issues, and thus have a direct connection with the concept of sustainability (para. 33). Finally,



regarding the services surrounding the creation of sustainable strategies and operations aimed at reducing environmental impact, the term ‘sustainable’ suggests, in a clear and unequivocal way, the common purpose of the services in question, which contribute, in a general manner, to preventing long-term ecological damage (para. 34). In sum, the mark Sustainable1 displays, from the point of view of the relevant public, a sufficiently direct and specific connection with the services for which protection was sought. **Distinctive character.** Since it has been held that the mark applied for was descriptive of the services in question, it is not necessary to rule on the second plea in law, alleging infringement of Article 7(1)(b) EUTMR.

**T-822/17; iGrill**; *Weber-Stephen Products LLC v EUIPO*; Judgment of 17 October 2018; EU:T:2018:693; Language of the case: EN. The applicant sought to register the word mark **iGrill** as an EUTM for goods in, inter alia, Classes 9 and 21. The Office refused to register the EUTM application pursuant to Article 7(1)(b) and (c) EUTMR, as it was descriptive and devoid of distinctive character. The applicant filed an appeal. The Board of Appeal (BoA) dismissed the appeal as it found that the contested mark was descriptive of the goods covered, insofar as the letter ‘i’, as a prefix, referred to the words ‘interactive’ and ‘intelligent’, or to information technology, and the word ‘grill’ referred to a cooking device, with the result that the relevant public would understand the term ‘iGrill’ as referring to an interactive, intelligent grill or a grill which makes use of information technology. The applicant filed an action before the General Court (GC), relying on two pleas in law: (i) infringement of Article 7(1)(b) EUTMR and (ii) infringement of Article 7(1)(c) EUTMR. **Relevant public.** The relevant public is the English-speaking public in the EU, comprising both the general public and a specialised public (para. 22). **Meaning of the mark.** The word ‘grill’ is a common word in English, referring to a cooking device, and will be understood as such. It is a well-known fact that the letter ‘i’ can mean ‘intelligent’ or refer to information technology (para. 25). The contested mark will be seen as the mere juxtaposition of the two elements ‘i’ and ‘grill’ of which it is composed and not a neologism consisting of a single word which has no obvious meaning (para. 26). The mere fact that the possible meaning of the letter ‘i’ is not referred to in the dictionaries mentioned by the applicant does not lead to the conclusion that the relevant public will not be able to perceive that meaning (para. 30). **Descriptiveness.** The computer hardware in Class 9 may be required to operate a device, including a grill, which makes use of information technology, without there being any need to determine whether or not that hardware must make it possible for grills to be used remotely. Similarly, grill covers and household, kitchen and barbecue utensils and containers in Class 21 may be used with a grill. In that regard, the applicant neither demonstrates, nor even claims, that the fact that a grill may make use of information technology is such as to make the use of grill covers and household, kitchen and barbecue utensils and containers unnecessary (para. 39). The fact that the contested mark describes a characteristic which does not exist, as technology currently stands, does not preclude it from being perceived as descriptive by the relevant public (para. 41). Moreover, it was sufficient to find that, in one of its possible meanings, the contested mark designated a characteristic of the goods covered, regardless of whether or not such products are currently available on the market (para. 42). **On previous decision-making practice of the Office.** The fact that the Office interpreted the letter ‘i’ differently in previous decisions and allowed the registration of marks with the letter ‘i’ as a prefix, even though the goods and services of those marks are part of the information technology sector, does not lead to the conclusion that the BoA infringed Article 7(1)(c) EUTMR (para. 47). The registration of a sign as a mark depends on specific criteria, which are applicable in the factual circumstances of the particular case (para. 45).

♦ **T-758/17; PERFECT BAR**; *Perfect Bar LLC v EUIPO*; Judgment of 8 November 2018;



EU:T:2018:762; Language of the case: EN. The applicant sought to register the word mark **PERFECT BAR** as an EUTM for *nutritional energy bars for use as a meal substitute; nutritional supplement meal replacement bars for boosting energy; nutritional supplement energy bars; protein supplements; dietary and nutritional supplements; nutritional supplements in the form of bars and bites; nutritional supplements in the form of food bars for use as a meal substitute; nutritional and dietary supplements formed and packaged as bars* in Class 5. The Office refused to register the EUTM application pursuant to Article 7(1)(c) and (b) EUTMR, as it was descriptive and devoid of distinctive character. The applicant filed an appeal. The Board of Appeal (BoA) dismissed the appeal. It found that the mark applied for was descriptive of the nature and quality of the goods in question, given that the English-speaking part of the general public would understand the word elements of the mark applied for as referring to a bar of food having all essential elements and being excellent in all respects. Insofar as the mark was descriptive of the nature and quality of the goods in question, it was devoid of distinctive character for those goods. The applicant appealed to the General Court (GC), relying on two pleas in law: (i) infringement of Article 7(1)(c) EUTMR and (ii) infringement of Article 7(1)(b) EUTMR. **Descriptiveness.** The combination of the word elements of the mark refers to goods presented in the form of a bar that is excellent in all respects. This is one of the possible meanings of ‘perfect bar’, and one that does not require any additional cognitive effort to perceive (paras 24-27). Therefore, as regards the goods presented in the form of a bar, the BoA validly concluded that the mark applied for is descriptive (para. 39). However, the BoA had not established to the requisite legal standard the descriptive character of the mark in relation to *protein supplements* and *dietary and nutritional supplements* because it has not been established whether these specifications include goods presented in the form of a bar (paras 51-53). The applicant cannot validly rely on the fact that the Office has registered similar marks in order to seek annulment of the BoA decision for the goods in the form of a bar, as the Office had established the descriptive character of the mark for such goods based on the EUTMR (paras 56-60). The applicant cannot rely either on the fact that an identical mark was registered in the United States, as an EU mark must be assessed by reference only to the relevant EU rules and, consequently, the EU Courts are not bound by a decision in a third country (paras 61-63). **Distinctive character.** Insofar as the mark applied for is descriptive for the goods in the form of a bar, it also lacks distinctive character (para. 72). However, since it has not been established whether the mark is descriptive for *protein supplements* and *dietary and nutritional supplements*, the conclusion that it automatically lacks distinctiveness for these goods is invalid (para. 74). Consequently, it is necessary to annul the contested decision insofar as these goods are concerned (para. 76).

♦ [T-759/17](#); **PERFECT BAR (fig.)**; *Perfect Bar LLC v EUIPO*; Judgment of 8 November 2018; EU:T:2018:760; Language of the case: EN.



The applicant sought to register the figurative mark above as an EUTM for *nutritional energy bars for use as a meal substitute; nutritional supplement meal replacement bars for boosting energy; nutritional supplement energy bars; protein supplements; dietary and nutritional supplements; nutritional supplements in the form of bars and bites; nutritional supplements in the form of food bars for use as a meal substitute; nutritional and dietary*



*supplements formed and packaged as bars* in Class 5. The Office refused to register the EUTM application pursuant to Article 7(1)(c) and (b) EUTMR, as it was descriptive and devoid of distinctive character. The applicant filed an appeal. The Board of Appeal (BoA) dismissed the appeal. It found that the mark applied for was descriptive of the nature and quality of the goods in question. This was because first, the English-speaking part of the general public would understand the word elements of the mark applied for as referring to a bar of food having all essential elements and being excellent in all respects and, second, the figurative elements of the mark applied for, which are decorative, were not sufficient to divert the relevant public's attention from the descriptive message of the word elements. Insofar as the mark was descriptive of the nature and quality of the goods in question, it was devoid of distinctive character for those goods. The applicant appealed to the General Court (GC), relying on two pleas in law: (i) infringement of Article 7(1)(c) EUTMR and (ii) infringement of Article 7(1)(b) EUTMR. **Descriptiveness.** The combination of the word elements of the mark refers to goods presented in the form of a bar that is excellent in all respects. This is one of the possible meanings of 'perfect bar', and one that does not require any additional cognitive effort to perceive (paras 24-27). The figurative elements, namely the position of the word elements perpendicular to each other, the different sizes and fonts, the rectangular frames and the contrast of black and white, correspond to standard graphic elements that will be perceived by the relevant public as simple decorative elements. Moreover, it cannot be ruled out that these will emphasise the message of the word 'bar' by reinforcing the expected form of a bar (para. 32). Therefore, for the goods presented in the form of a bar, the BoA validly concluded that the mark applied for is descriptive (para. 42). However, the BoA had not established to the requisite legal standard the descriptive character of the mark in relation to *protein supplements* and *dietary and nutritional supplements* because it has not been established whether these specifications include goods in the form of a bar (paras 54-56). The applicant cannot validly rely on the fact that the Office has registered similar marks in order to seek annulment of the BoA decision for goods in the form of a bar, as the Office had established the descriptive character of the mark for such goods on the basis of the EUTMR (paras 59-62). Furthermore, the applicant cannot rely on the fact that an identical mark was registered in the United States, as an EU mark must be assessed by reference only to the relevant EU rules and, consequently, the EU Courts are not bound by a decision in a third country (paras 64-66).

**T-140/18; LITECRAFT;** *LMP Lichttechnik Vertriebs GmbH v EUIPO*; Judgment of 15 November 2018; EU:T:2018:789; Language of the case. DE. The applicant sought to register the word mark **LITECRAFT** for goods in Classes 9 and 11. The Office refused the application for registration on the basis of Article 7(1)(b) and (c) EUTMR and Article 7(2) EUTMR. The applicant filed an appeal against the Office's decision. The Board of Appeal (BoA) dismissed the appeal as it considered that the sign was descriptive. The applicant filed an action with the General Court (GC), relying on two pleas in law: (i) infringement of Article 7(1)(c) EUTMR and (ii) infringement of Article 7(1)(b) EUTMR. **Infringement of Article 7(1)(c) EUTMR.** The BoA considered that the relevant public was composed of both consumers with a more or less high degree of attention and a specialised public with a high degree of attention. Since the sign contained English words, it was necessary to take into account the understanding of the relevant English-speaking public (para. 16). The BoA correctly considered that the sign meant in English 'talent for light' or 'ability regarding light'. The fact that the term does not exist as such in the English language does not affect this assessment. The relevant English-speaking public will perceive the mark applied for as the juxtaposition of the terms 'lite' and 'craft' and may confer on it the meaning of 'talent for light' or 'ability regarding light' (para. 18). The BoA rightly considered that the products concerned could be divided into three categories, namely lighting fixtures, lighting control



fixtures and instruments and electrical and electronic accessories for lighting fixtures. For the first two categories the term ‘litecraft’ would be perceived by the relevant English-speaking public as an indication describing their type, destination and quality. For the third category the products had a close complementary connection with lighting. Consequently, the contested decision correctly considered that, from the point of view of the relevant public, there was a sufficiently direct and concrete connection between that term and the goods in question and thus the sign at issue is descriptive within the meaning of Article 7(1)(c) EUTMR (para. 20). **Infringement of Article 7(1)(b) EUTMR.** Consequently, the present plea is inoperative. The BoA rightly considered that the sign applied for lacked distinctive character within the meaning of Article 7(1)(b) EUTMR.

**T-790/17** and **T-791/17**; **ST ANDREWS**; *St. Andrews Links Ltd v EUIPO*; Judgment of 20 November 2018; EU:T:2018:811; Language of the case. EN. The applicant sought to register the word mark **ST ANDREWS** as an EUTM for goods and services in Classes 25, 28, 35 and 41. The Office refused to register the EUTM application pursuant to Article 7(1)(b) and (c) and Article 7(3) EUTMR, as it was descriptive of certain positive characteristics of the goods and services covered. Furthermore, the evidence adduced by the applicant was found insufficient to prove acquired distinctiveness through the use of the contested mark. The applicant filed an appeal and the Board of Appeal (BoA) partially dismissed the appeal. It found that a link could be established between several of the contested mark’s services in Class 41 and the expression ‘St Andrews’. Those services were all directly related to the sport of golf, in other words, to the particular field for which the town of St Andrews (United Kingdom) is very well known. Consequently, the use of that expression in connection with those services would be perceived by the relevant public as a descriptive indication of the geographical origin of those services. The applicant appealed to the General Court (GC), relying on a single plea in law. Infringement of Article 7(1)(c) EUTMR. **Relevant public.** The relevant public is composed both of average consumers and golf professionals and amateurs in the EU (para. 28). **Meaning of the mark.** The mark consists of a sole expression which refers to a place well known for the sport of golf and for which the services are, inter alia, *arranging and conducting competitions, club services (entertainment or education)*, etc., and will therefore indicate, at the very least to golf professionals and amateurs, that those services relate to golf (para. 56). **Link between the mark and the services.** (i) The services could all directly relate to the sport of golf, and in particular to the organisation and planning of golf events, competitions, etc., that is, to the particular field for which the town of St Andrews is well known (para. 35). (ii) The contested mark’s services do not possess any particular quality that could lead the relevant public to disassociate the geographical indication from the geographical origin of those services (para. 36). (iii) The services could, to a certain extent and for part of the relevant public, be linked to some specific competitions that are played on the applicant’s courses (para. 37). (iv) There is a link between the expression ‘St Andrews’, in the mind of the relevant public, at the very least insofar as golf professionals and amateurs are concerned, and the contested mark’s services in Class 41 (para. 38). (v) The expression ‘St Andrews’ is likely to designate the geographical origin of those services. Therefore, there is a link between the expression ‘St Andrews’, in the mind of the relevant public, at the very least insofar as golf professionals and amateurs are concerned, and the services covered in Class 41, and the expression ‘St Andrews’ is likely, in that public’s mind, to designate the geographical origin of those services (para. 38).

♦ **T-82/17**; **Exxtra Deep**; *PepsiCo, Inc. v EUIPO*; Judgment of 21 November 2018; EU:T:2018:814; Language of the case: EN. The EUTM proprietor registered the word mark **Exxtra Deep** as an EUTM for goods in Classes 29, 30 and 31. An invalidity application was filed pursuant to Article 59(1)(a) EUTMR in conjunction with Article 7(1)(b) and (c) EUTMR.



The Cancellation Division (CD) partially granted the invalidity application. It noted that some goods, in particular, *dried fruits and vegetables*, were not sold cut into ridges in the same way as crisps and therefore concluded that registration of the contested mark had to be maintained for *preserved, dried, and cooked fruits and vegetables* in Class 29. The invalidity applicant appealed, but the Board of Appeal (BoA) dismissed the appeal and confirmed that the contested mark was neither descriptive nor devoid of distinctive character for *preserved, dried, and cooked fruits and vegetables* in Class 29. According to the BoA, the relevant public could, at most, view the contested mark as an allusion to a particular cut of vegetables or fruits, but not as a description of the characteristics of those goods. The invalidity applicant appealed to the General Court (GC), relying on two pleas in law: (i) infringement of Articles 7(1)(b) and (c) EUTMR, and (ii) infringement of Article 33(2), (4) and (5) EUTMR. Snack products, in particular crisps, are made from potatoes, which are vegetables, as demonstrated by the definition in the Oxford English Dictionary produced before the Office (para. 54). However, crisps can be made from vegetables other than potatoes, or from fruit (para. 55). Crisps made from vegetables or fruit could be regarded as dried or cooked vegetables or fruits, and they can be fried, dried or cooked (para. 56). Fruit and vegetables in Class 29 are *preserved, dried and cooked*. Crisps, or more broadly, *extruded and pelletised or otherwise manufactured or processed vegetable and potato products for snacks*, are produced from preserved, dried or cooked vegetables and fruits (para. 57). Therefore, *extruded and pelletised or otherwise manufactured or processed vegetable and potato products for snacks* in Class 29 are covered by the *preserved, dried and cooked fruit and vegetables* category in the same class (para. 58). There is a certain inconsistency in the Office's recent decision-making practice in regard to *preserved, dried, and cooked fruits and vegetables* (para. 62). In order to assess its descriptive character for *preserved, dried or cooked fruits and vegetables* in the same class, the BoA should have taken into account the finding that the contested mark had descriptive character for *extruded and pelletised or otherwise manufactured or processed vegetable and potato products for snacks* in Class 29 (para. 64). Consequently, the contested decision must be annulled insofar as it did not refuse the contested mark for *preserved, dried and cooked fruits and vegetables* in Class 29 (para. 66).

**T-9/18; STRAIGHTFORWARD BANKING; Addiko Bank AG v EUIPO**; Judgment of 22 November 2018; EU:T:2018:827; Language of the case: EN. The applicant sought to register the word mark **STRAIGHTFORWARD BANKING** as an EUTM for, inter alia, *financial affairs; monetary affairs* in Class 36. The Office refused to register the EUTM application for these services pursuant to Article 7(1)(b), (c) and Article 7(2) EUTMR. The applicant filed an appeal. The Board of Appeal (BoA) dismissed the appeal finding that the mark designates objectively the kind and quality of the services and that it would be understood as a promotional message and not as an indication of their commercial origin. The applicant filed an action before the General Court (GC), relying on two pleas in law: (i) infringement of Article 7(1)(c) EUTMR and (ii) infringement of Article 7(1)(b) EUTMR. **Descriptiveness.** It is undisputed that the relevant public is the English-speaking public in the EU composed, inter alia, of the general public (para. 19). Since the mark would be understood as making reference to the simplicity of the services provided by the applicant, which is a desirable feature, it constitutes a promotional formula referring to the quality of the services and therefore has a descriptive character within the meaning of Article 7(1)(c) EUTMR (paras 20-22). The fact that the relevant public could perceive the expression 'straightforward banking' as meaning that the applicant will seek to provide services relating to financial and monetary affairs in an understandable way, even though they are complex, does not confer on that expression an unusual character capable of indicating the commercial origin of the services (para. 24). Furthermore, the fact, if proved, that the expression 'straightforward banking' has never been used before in a way that is



descriptive of the services and that the word ‘straightforward’ may have several meanings, is not in itself sufficient to conclude that the mark applied for is devoid of any descriptive character, since that mark may, in at least one of its possible meanings, designate a characteristic of the services within the meaning of Article 7(1)(c) EUTMR (para. 25). The fact that the Office has held in previous decisions that, in the banking sector, the relevant public perceives marks with a descriptive character as an indication of the commercial origin of the services in question, does not lead to the conclusion that the BoA infringed Article 7(1)(c) EUTMR, as the Office is not bound by its previous decision-making practice but must rather undertake an examination of the factual circumstances of each specific case (paras 30-31). **Distinctive character.** Since the sign applied for has a descriptive character within the meaning of Article 7(1)(c) EUTMR, there is no need to consider the merits of the plea alleging infringement of Article 7(1)(b) EUTMR, as it is sufficient that one of the absolute grounds for refusal applies for the sign at issue not to be registrable as an EU trade mark (paras 37-38). The action must therefore be dismissed in its entirety.

♦[T-214/17](#); **FUNNY BANDS**; *Out of the blue KG v EUIPO*; Judgment of 29 November 2018; EU:T:2018:854; Language of the case: EN. The EUTM proprietors registered the word mark **FUNNY BANDS** as an EUTM for goods and services in Classes 14, 17 and 35. An invalidity application was filed pursuant to Article 59 EUTMR in conjunction with Article 7(1)(b) and (c) EUTMR. The Cancellation Division (CD) dismissed the invalidity application. The invalidity applicant filed an appeal. The Board of Appeal (BoA) dismissed the appeal. It found that the mark had an obscure meaning as regards the goods and services concerned and was thus not descriptive nor lacking in distinctive character. The invalidity applicant filed an action with the General Court (GC), relying on three pleas in law: (i) infringement of Article 7(1)(b) EUTMR, (ii) infringement of Article 7(1)(c) EUTMR and (iii) infringement of the principles of equal treatment and the protection of legitimate expectations. At the hearing before the GC, the invalidity applicant withdrew part of its action and stated that it was challenging the CD decision only insofar as it confirmed the CD rejection of the invalidity application for part of the goods and services. **Descriptiveness.** The combination of the words ‘funny’ and ‘bands’, separated by a space, which is consistent with English grammar rules, will be understood by a significant part of the relevant public as referring to ‘bands’ which are ‘funny’, that is to say flat, thin strips or loops of material, used as fasteners, for reinforcement, or as decoration, which are humorous, strange or curious (paras 34, 37). Although the question whether something is ‘funny’ is the result of a subjective assessment, the combination of this term and the term ‘bands’ conveys to the consumer a specific message as regards the characteristic of those ‘bands’; it immediately informs the relevant public, without further reflection, of the fact that the ‘bands’ are of a particular design, for instance using unusual colours, awkward shapes or humorous motifs and, in consequence, seek to provoke laughter or create a strange or curious appearance. Therefore, the term ‘funny’ describes the nature and purpose of the ‘bands’ (para. 49). The BoA was therefore incorrect to take the view that the term ‘funny’ cannot serve to designate a characteristic of goods designated by the term ‘band’ (para. 50). **Partial annulment of the BoA decision.** The BoA decision must be annulled insofar as it rejected the invalidity applicant’s action with respect to the part of the goods and services not concerned by the withdrawal at the hearing before the GC. It is not necessary to examine the applicant’s third plea in law (para. 55).

[C-629/17](#); **Portugal Ramos Vinhos (adegaborba)**; *J. Portugal Ramos Vinhos SA v Ageda Cooperativa de Borba CRL*; Preliminary ruling of 6 December 2018; EU:C:2018:988; Language of the case: EN. The applicant brought an application for cancellation of the registration by Ageda Cooperativa de Borba of several national trade marks, one of which consisted of the word mark **adegaborba.pt**, which designated wine products. This action





was dismissed, at the first instance, by the Tribunal da Propriedade Intelectual (Intellectual Property Court, Portugal) and, on appeal, by the Tribunal da Relação de Lisboa (Lisbon Court of Appeal, Portugal). Both courts held that the word mark **adegaborba.pt**, when adopted by a producer from the Borba (Portugal) region, did not fall within the scope of Article 223(1)(c) of the Portuguese Industrial Property Code. More specifically, the Tribunal da Relação de Lisboa (Lisbon Court of Appeal) held that the term ‘adega’ was a distinctive term in the wine sector, designating wines coming from producers in the cooperative Adegas Cooperativas de Borba. The applicant appealed against the decision of the Tribunal da Relação de Lisboa (Lisbon Court of Appeal) to the referring court, the Supremo Tribunal de Justiça (Supreme Court, Portugal). That court explains that the dispute before it concerns only the word mark **adegaborba.pt**, whose distinctive character must be determined. The referring court states that this trade mark was used by a legal person, the Adegas Cooperativas de Borba, whose name includes the term ‘adega’. The referring court notes that Article 223(1)(c) of the Portuguese Industrial Property Code refers to indications designating the ‘means of production’ of goods, while Article 3(1)(c) Directive 2008/95/EC does not explicitly refer to ‘means of production’ but mentions ‘other characteristics’ of the goods which can be regarded as descriptive of them. The referring court wonders whether the term ‘adega’ (‘cellar’), when used in the field of wine making, should be considered as a purely descriptive term, in that it refers to a means of production of these goods, or if it refers to a mere characteristic of those goods, in addition to those set out in Directive 2008/95/EC. The referring court asks, in essence, whether Article 3(1)(c) Directive 2008/95/EC must be interpreted as meaning that the registration of a trade mark, composed of a word mark designating wine products and including a geographical name, must be refused where that sign contains, in particular, a term which is commonly used to designate facilities or sites in which those products are produced and is also one of the word elements making up the business name of the legal person seeking to register that trade mark (para. 15). **Findings of the Court of Justice of the European Union (CJEU).** The relevant term ‘adega’, has two meanings in Portuguese: (i) underground premises in which wine in particular is kept, and (ii) premises or facilities in which wine products, such as wine itself, are produced (para. 21). Where a term refers to the place of production of a product, such as wine, or to a facility in which it is produced, it is, in principle, an indication which may serve to designate a property of those goods, easily recognisable (para. 22). The relevant public, as a general rule, will perceive the term ‘adega’ to be a reference to a facility in which wine is produced and stored, and, therefore, as a reference to properties of those goods (para. 23). Therefore, a term designating such a facility constitutes a characteristic of those goods and it must therefore be regarded as descriptive of the goods which it designates (para. 24). Where a sign serving to designate goods associates two word elements, namely a descriptive term and a geographical name, such as ‘Borba’ in this case, relating to the geographical origin of those goods, which is also descriptive of them, the sign must be considered to be of a descriptive character and, as such, devoid of any distinctive character (para. 25). The fact that a term used to designate a place of production of goods, or a facility in which the goods are produced, is part of various word elements of the corporate name of a legal person is irrelevant for the purposes of examining the descriptive character of that term (para. 27). Article 3(1)(c) Directive 2008/95/EC must be interpreted as meaning that a trade mark consisting of a word mark designating wine products and including a geographical name, must be refused registration, where that sign contains, in particular, a term which is commonly used to designate facilities or sites in which such products are produced and is also one of the word elements of the business name of the legal person seeking to register that trade mark (para. 28).

**T-98/18; MULTIFIT; Multifit Tiernahrungs GmbH v EUIPO;** Judgment of 13 December 2018; EU:T:2018:936; Language of the case: DE. The applicant sought to register the word



mark **MULTIFIT** as an EUTM for goods in Classes 5, 28 and 31. The Office refused to register the EUTM application pursuant to Article 7(1)(b) and (c) and Article 7(2) EUTMR. The applicant filed an appeal, which was dismissed by the Board of Appeal (BoA). The applicant filed an action with the General Court (GC), relying on a single plea in law: infringement of Article 7(1)(b) EUTMR. The BoA considered that the application's goods were intended for both the general public, in particular animal owners, and specialists, in particular pet shop staff owners. The relevant public consisted of English-speaking consumers in the European Union, since the trade mark applied for was composed of English terms. The degree of attentiveness was taken to be that of a consumer with experience in the sector in question, reasonably well informed and reasonably observant and circumspect. The applicant did not dispute these findings (para. 19). The application's goods are intended to promote animal welfare (para. 20). The trade mark is composed of two common English terms, namely 'multi' and 'fit'. The term 'multi' is a verbal element that means 'many' and is used as a prefix in a large number of English words. The term 'fit' has several meanings such as 'suitable, correct' or 'in good physical condition' (para. 21). The BoA rightly considered that the trade mark applied for, as a whole, will be easily understood by the relevant public as meaning 'suitable in many respects' or 'in good physical shape in many respects' (para. 23). As rightly considered by the BoA, the trade mark applied for is of a laudatory nature, since it emphasises positive aspects of the goods concerned and can be considered as an indication of quality or an incentive to purchase said goods (para. 25). The trade mark applied for is an ordinary advertising message that is not likely to trigger a cognitive process in the public concerned (para. 28). The BoA was right when it considered that the trade mark applied for was devoid of distinctive character (para. 32). The BoA considered that the absolute grounds for refusal related to a lack of distinctiveness and descriptiveness, and that each had a separate scope of application and were neither interdependent nor mutually exclusive (para. 35). The BoA decision cited by the applicant was taken on the basis of Article 7(1)(c) EUTMR and not on the basis of Article 7(1)(b) EUTMR (para. 45). It should be recalled that proof of genuine use of the mark applied for is not a relevant factor in the application of Article 7(1)(b) EUTMR (para. 47). The applicant did not invoke Article 7(3) EUTMR or argue that the trade mark applied for had acquired distinctive character through use (para. 49). The action must therefore be dismissed (para. 51).

♦ [T-830/16](#); **PLOMBIR**; *Monolith Frost GmbH v EUIPO*; Judgment of 13 December 2018; EU:T:2018:941; Language of the case: DE. Pursuant to Article 59(1)(a) EUTMR and Article 7(1)(c) EUTMR an application for declaration of partial invalidity was filed against the word mark **PLOMBIR** as far as it was registered for goods in Classes 29 (*compotes, eggs, milk and milk products*) and 30 (*coffee, cocoa, ices*). The Cancellation Division (CD) granted the application for a declaration of invalidity for *milk and milk products* in Class 29 and *ices* in Class 30 since it held **PLOMBIR** as being descriptive. The intervener (cancellation applicant) filed an appeal. The Board of Appeal (BoA) annulled CD's decision. It found that the applicant had not shown that the Russian word is understood in the European Union, and in particular not in Germany. The applicant filed an action before the General Court (GC), relying on three pleas in law: (i) infringement of Article 7(1)(c) EUTMR, (ii) infringement of the principle of *ex officio* examination of the facts provided for in Article 95(1) EUTMR and (iii) infringement of the obligation to state reasons provided for in Article 94 EUTMR. The BoA infringed Article 95(1) EUTMR in that it could not exclude nationals of the Baltic States from the definition of the relevant public on the sole ground of an absence of concrete evidence as to the understanding of Russian in those countries, without first deciding whether it was known that Russian was frequently understood by that population (para. 35). The BoA committed an error of assessment in determining the relevant public and a breach of Article 7(2) EUTMR, since the relevant public in relation to



which the absolute ground for refusal had to be assessed was a Russian-speaking public, including the general public of the European Union who understand or speak Russian, and reside in Germany and the Baltic States (para. 60). In particular it was held sufficient that only 3 per cent of Germans understand Russian. Insofar as the term ‘plombir’ constitutes the faithful transliteration of the term ‘Пломбир’ into letters of the Latin alphabet known by the relevant Russian-speaking consumer of the European Union, its descriptive meaning is likely to be immediately and directly understood by that consumer (para. 75). As a result, there is no need to consider the third plea (para. 77).

**T-7/18; Business and technology working as one; *Inforsacom Logicalis GmbH v EUIPO***; Judgment of 14 December 2018; EU:T:2018:974; Language of the case: DE. The applicant sought to register the word mark **Business and technology working as one** as an EUTM for goods and services in Classes 9, 16, 35, 37, 38, 39, 41 and 42. The Office refused to register the EUTM application pursuant to Article 7(1)(a) and (b) EUTMR, and Article 7(2) EUTMR. The applicant appealed and the Board of Appeal (BoA) dismissed the appeal, as it found that the mark was descriptive and devoid of distinctive character. The applicant filed an action before the General Court (GC), relying on a single plea in law: infringement of Article 7(1)(b) and (c) in conjunction with Article 7(2) EUTMR. **Relevant public.** As the mark is made up of an English statement (two English components), the relevant public consists of English-speaking consumers or ones that at least have sufficient knowledge of English, namely knowledge of essential specialist English vocabulary. The level of attention is high, as specialist computer programs and computer services, training and related consultancy and practices are relatively expensive consumer goods and services (para. 7) **Meaning of the mark.** The slogan states that business aspects and technological solutions are closely linked to one another (para. 7). **Descriptiveness.** Regarding the goods in Class 9, it is already apparent from the description that, for instance, a single piece of software combines various aspects, namely the finance functions, as well as the production and sales functions of a business. This corresponds precisely to the meaning of the trade mark, namely that technological and business aspects are combined in one solution. Hardware is likewise particularly suitable for such a purpose (para. 24). Without any particular reflection, the public will associate the technological aspects with the functioning of commercial aspects (para. 25). Regarding the goods in Class 16, *printed matter* may also be used for normal business operations together with technologies/technological innovations. Likewise, *photographs* may be used for explanatory purposes in manuals which may be specialised in the subject of bringing together technology and business management. Furthermore, use of *stationery* and *office requisites* with modern technology may ensure the smooth running of everyday business life (para. 26). All the services at issue can be used in a technically- and business-oriented manner. In this context, *business* and *technology* work together as one, that is to say the services use the technology in such a way that the economic objectives are achieved without obstacles (para. 29). Therefore, there is a clear and direct connection between the mark at issue and the goods and services (para. 32). Since the mark is descriptive, there is no need to assess if the relevant public would perceive the contested mark as a slogan (para. 35). It is sufficient that one of the absolute grounds for refusal applies in order for the sign not to be registrable as an EUTM; therefore, there is no need to assess distinctiveness (para. 40).



♦[T-801/17](#); **ORIGINAL excellent dermatest 3-star-guarantee.de (fig.)**; *Dermatest Gesellschaft für allergologische Forschung u. Vertrieb von Körperpflegemitteln mbH v EUIPO*; Judgment of 14 December 2018; EU:T:2018:970; Language of the case: DE

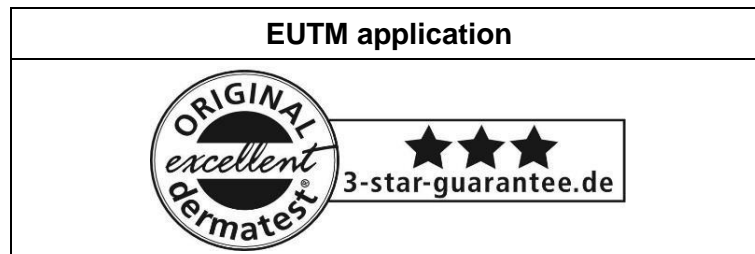

The applicant sought to register the figurative mark above as an EUTM for *services of a medical and bacteriological laboratory; medical research; production of expertise in the field of allergology (scientific services); all the aforementioned services exclusively for companies in the cosmetics sector, in particular for companies developing and/or manufacturing and/or distributing cosmetics* in Class 42. The Office refused to register the EUTM application pursuant to Article 7(1)(b) and (c) EUTMR. The applicant appealed. The Board of Appeal (BoA) dismissed the appeal finding that the mark was descriptive and non-distinctive and that the evidence provided by the applicant did not prove the acquisition of distinctive character through the use of the mark applied for. The applicant filed an action before the General Court (GC), relying on three pleas in law: (i) infringement of Article 7(1)(b) EUTMR, (ii) infringement of Article 7(1)(c) EUTMR and (iii) infringement of Article 7(3) EUTMR. **Relevant public.** Since the verbal elements of the mark applied for are English words and bearing in mind the services, the existence of an absolute ground for refusal must be assessed in relation to the English-speaking public specialised in the cosmetics sector of the European Union (EU) (paras 25, 30). **Descriptiveness.** The word elements of the mark would be understood to mean ‘original skin test, excellent, three-star guarantee’ and the relevant specialist public would perceive the suffix ‘.de’ as part of the address of a German website indicating that the services in question were available on the internet (para. 39). Having regard to the nature of the services and the immediate meaning of the word elements, the mark as a whole is descriptive of those services (para. 41). Because of their banality and extreme graphic simplicity, the figurative elements of the sign would not divert the attention of the relevant public from the descriptive message conveyed by the word elements, and that public would perceive the mark, taken as a whole, as a description of the purpose of the services and not as indicating their origin (paras 45-46). The term ‘dermatest’ preceded by the term ‘original’ and followed by the symbol ‘®’ cannot constitute an indication of the origin of the services, as the element ‘original’ designates a characteristic of the service concerned and the symbol ‘®’, as is clear from case-law, does not have any characteristic enabling the relevant public to distinguish the services for which protection was sought from those with another commercial origin (paras 49-50). The specialised public, whose linguistic knowledge encompasses both everyday and specialised language will understand, at first sight, the word elements of the mark applied for and, in particular, the word element ‘dermatest’ as a description of the services meaning ‘skin test’ and not as a reference to the applicant (paras 52-55). The applicant cannot decisively rely on the fact that it owns an earlier word mark ‘dermatest®’ and a figurative mark corresponding to the mark applied for but whose word elements are in German, since the principles of equal treatment and good administration must be reconciled with respect for legality (paras 56-58). **Lack of distinctive character.** Since the mark is descriptive, this is sufficient to conclude that it is also devoid of distinctive character bearing in mind the overlap between the absolute grounds for refusal provided for in Article 7(1)(c) and (b)



EUTMR (paras 63-65).

♦[T-802/17](#); **ORIGINAL excellent dermatest 5-star-guarantee.de CLINICALLY TESTED** (fig.); *Dermatest Gesellschaft für allergologische Forschung u. Vertrieb von Körperpflegemitteln mbH v EUIPO*; Judgment of 14 December 2018; EU:T:2018:971; Language of the case: DE



The applicant sought to register the figurative mark above as an EUTM for *services of a medical and bacteriological laboratory; medical research; production of expertise in the field of allergology (scientific services); all the aforementioned services exclusively for companies in the cosmetics sector, in particular for companies developing and/or manufacturing and/or distributing cosmetics* in Class 42. The Office refused to register the EUTM application pursuant to Article 7(1)(b) and (c) EUTMR. The applicant appealed. The Board of Appeal (BoA) dismissed the appeal finding that the mark was descriptive and non-distinctive and that the evidence provided by the applicant did not prove the acquisition of distinctive character through the use of the mark applied for. The applicant filed an action before the General Court (GC), relying on three pleas in law: (i) infringement of Article 7(1)(b) EUTMR, (ii) infringement of Article 7(1)(c) EUTMR and (iii) infringement of Article 7(3) EUTMR. **Relevant public.** Since the verbal elements of the mark applied for are English words and bearing in mind the services, the existence of an absolute ground for refusal must be assessed in relation to the English-speaking public specialised in the cosmetics sector of the European Union (EU) (paras 25, 30). **Descriptiveness.** The word elements of the mark would be understood to mean ‘original skin test, excellent, five-star guarantee, clinically tested’ and the relevant specialist public would perceive the suffix ‘.de’ as part of the address of a German website indicating that the services in question were available on the internet (para. 39). Having regard to the nature of the services and the immediate meaning of the word elements, the mark as a whole is descriptive of those services (para. 41). Because of their banality and extreme graphic simplicity, the figurative elements of the sign would not divert the attention of the relevant public from the descriptive message conveyed by the word elements, and that public would perceive the mark, taken as a whole, as a description of the purpose of the services and not as indicating their origin (paras 45-46). The term ‘dermatest’ preceded by the term ‘original’ and followed by the symbol ‘®’ cannot constitute an indication of the origin of the services, as the element ‘original’ designates a characteristic of the service concerned and the symbol ‘®’, as is clear from case-law, does not have any characteristic enabling the relevant public to distinguish the services for which protection was sought from those with another commercial origin (para. 50). The specialised public, whose linguistic knowledge encompasses both everyday and specialised language will understand, at first sight, the word elements of the mark applied for and, in particular, the word element ‘dermatest’ as a description of the services meaning ‘skin test’ and not as a reference to the applicant (paras 52-55). The applicant cannot decisively rely on the fact that it owns an earlier word mark ‘dermatest®’ and a figurative mark corresponding to the mark applied for but whose word elements are in German, since the principles of equal treatment and good administration must be reconciled with respect for legality (paras 56-58). **Lack of distinctive character.** Since the



mark is descriptive, this is sufficient to conclude that it is also devoid of distinctive character bearing in mind the overlap between the absolute grounds for refusal provided for in Article 7(1)(c) and (b) EUTMR (paras 63-65).

♦[T-803/17](#); **ORIGINAL excellent dermatest (fig.)**; *Dermatest Gesellschaft für allergologische Forschung u. Vertrieb von Körperpflegemitteln mbH v EUIPO*; Judgment of 14 December 2018; EU:T:2018:973; Language of the case: DE



The applicant sought to register the figurative mark above as an EUTM for *services of a medical and bacteriological laboratory; medical research; production of expertise in the field of allergology (scientific services); all the aforementioned services exclusively for companies in the cosmetics sector, in particular for companies developing and/or manufacturing and/or distributing cosmetics* in Class 42. The Office refused to register the EUTM application pursuant to Article 7(1)(b) and (c) EUTMR. The applicant appealed. The Board of Appeal (BoA) dismissed the appeal finding that the mark was descriptive and non-distinctive and that the evidence provided by the applicant did not prove the acquisition of distinctive character through the use of the mark applied for. The applicant filed an action before the General Court (GC), relying on three pleas in law: (i) infringement of Article 7(1)(b) EUTMR, (ii) infringement of Article 7(1)(c) EUTMR and (iii) infringement of Article 7(3) EUTMR. **Relevant public.** Since the verbal elements of the mark applied for are English words and bearing in mind the services, the existence of an absolute ground for refusal must be assessed in relation to the English-speaking public specialised in the cosmetics sector of the European Union (EU) (paras 25, 30). **Descriptiveness.** The word elements of the mark would be understood to mean ‘original skin test, excellent’ (para. 40). Having regard to the nature of the services and the immediate meaning of the word elements, the mark as a whole is descriptive of those services (para. 42). Because of their banality and extreme graphic simplicity, the figurative elements of the sign would not divert the attention of the relevant public from the descriptive message conveyed by the word elements, and that public would perceive the mark, taken as a whole, as a description of the purpose of the services and not as indicating their origin (paras 46-47). The term ‘dermatest’ preceded by the term ‘original’ and followed by the symbol ‘®’ cannot constitute an indication of the origin of the services, as the element ‘original’ designates a characteristic of the service concerned and the symbol ‘®’, as is clear from case-law, does not have any characteristic enabling the relevant public to distinguish the services for which protection was sought from those with another commercial origin (paras 50-51). The specialised public, whose linguistic knowledge encompasses both everyday and specialised language will understand, at first sight, the word elements of the mark applied for and, in particular, the word element ‘dermatest’ as a description of the services meaning ‘skin test’ and not as a reference to the applicant (paras 53-56). The applicant cannot decisively rely on the fact that it owns an earlier word mark ‘dermatest®’ and a figurative mark corresponding to the mark applied for but whose word elements are in German, since the principles of equal treatment and good administration must be reconciled with respect for legality (paras 57-59). **Lack of distinctive character.** Since the mark is descriptive, this



is sufficient to conclude that it is also devoid of distinctive character bearing in mind the overlap between the absolute grounds for refusal provided for in Article 7(1)(c) and (b) EUTMR (paras 64-66).

#### 4. Outcome: Not descriptive (Article 7(1)(c) EUTMR)

♦ [T-765/16](#); **EL TOFIO El sabor de CANARIAS (fig.)**; *Grupo Ganaderos de Fuerteventura, S.L. v EUIPO*; Judgment of 25 January 2018; EU:T:2018:31; Language of the case: ES



The applicant sought to register the figurative mark above for a list of goods in Class 29, inter alia, *milk, cheese and milk products; edible fats*. The Office refused to register the mark as an EUTM in its entirety on the grounds of Article 7(1)(c) EUTMR. ‘TOFIO’, a bowl linked to the ‘majorera’ culture used to collect goat’s milk, would immediately inform consumers that these ‘milk products’ originated from goats from the Canary Islands. The sign was also refused on the grounds that it infringed Article 7(1)(j) and (k) EUTMR. The applicant appealed the Office’s decision and requested a limitation of the relevant goods to *cheese*. The Board of Appeal (BoA) dismissed the applicant’s appeal because it found that the mark was descriptive — it is considered a well-known fact that Fuerteventura has a native race of goats (cabra majorera) used to elaborate Queso Majorero (PDO). ‘Tofio’ appears in the database of the Academia Canaria de la Lengua, as well as on social networks and in the Gran Enciclopedia Virtual Islas Canarias (GEVIC) database in the sense indicated in the Office’s decision. Therefore, the sign would be seen as descriptive of the kind of cheese protected. Registration in Spain is not binding and there is no need to evaluate as to Article 7(1)(j) EUTMR because refusal under one ground is sufficient.

**Descriptiveness.** Signs covered by Article 7(1)(c) EUTMR are only those that designate an easily recognisable characteristic for the relevant section of the public of the goods or services in respect of which registration is sought (para. 38). The relevant public is the Spanish-speaking part of the general public located in the European Union (para. 40). As regards ‘EL TOFIO’, the dominant part of the EUTM application, the fact that it does not appear in a dictionary — as it is a simple term and does not constitute any verbal combination or an abbreviation — must be seen as a clue and an indication that the average consumer does not know this term (para. 44). The internet sites quoted in the contested decision on which the BoA based its decision are glossaries of terms specially linked to the culture of the Canary Islands. From these elements it cannot be deduced that ‘Tofio’, originating from Lanzarote and Fuerteventura, has a ‘clear’ meaning for the average Spanish consumer of the relevant goods (para. 45). This is equally applicable to the other citations to internet sites that appear in the contested decision. The fact that a particular term is no longer in use can have an impact on the relevance of the knowledge of the public (para. 46). Even if some consumers might associate ‘Tofio’ with a traditional bowl forming part of the culture of some of the Canary Islands, the BoA has not produced any element that would enable the breadth of the knowledge of the function of the bowl on the part of the



relevant public to be determined and, as a consequence, of its possible relationship with the goods in question (para. 47). Therefore, ‘Tofio’ does not provide a sufficiently clear and direct meaning for Spanish-speaking consumers to see it as descriptive. In order to apply Article 7(1)(c) EUTMR, it is sufficient that the grounds of refusal exist only with regard to a non-negligible part of the public. However, the evidence submitted does not enable such a conclusion to be reached in this case (para. 48). In the absence of a descriptive character in one of the elements, even if the other were to be descriptive, this absolute ground does not apply (para. 49).

♦ [T-665/16](#); €\$ (fig.); *Cinkciarz.pl sp. z o.o. v EUIPO*; Judgment of 8 March 2018; EU:T:2018:125; Language of the case: PL

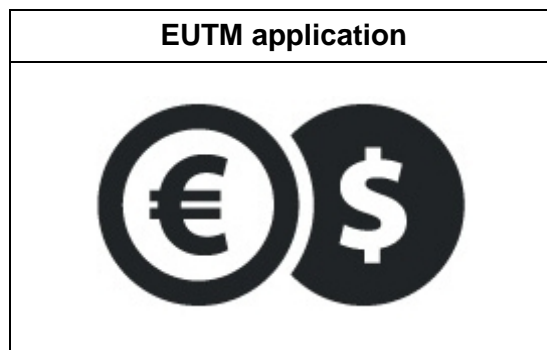

The EUTM applicant sought to register the figurative mark above for goods and services in Classes 9, 36 and 41. The Office informed the applicant that the registration of the EUTM application went against Article 7(1)(b) and (c) EUTMR. The applicant submitted observations and the Office refused the registration of the EUTM application pursuant to Article 7(1)(b) and (c) EUTMR for the abovementioned goods and services. The EUTM applicant appealed and the Board of Appeal (BoA) dismissed the appeal. It found that the mark was descriptive and non-distinctive. The EUTM applicant filed an action before the General Court (GC) relying on three pleas in law: (i) infringement of Article 7(1)(c) EUTMR, (ii) infringement of Article 7(1)(b) EUTMR and (iii) infringement of Article 7(1)(b) and (c) EUTMR. The contested mark refers to more than 80 goods and services in three different classes in different areas such as software, recording, transmission or reproduction apparatus of sound or images, foreign exchange operations, services of real estate agents, debt collection agencies, constitution of investment funds, credit and debit card issuance, insurance, real estate management or publications of texts other than advertising texts (para. 24). The BoA was wrong in finding that all the goods and services had a link with foreign exchange operations. For example the goods in Class 9, such as data carriers (magnetic and optical) or recording, transmission or reproduction apparatus of sound or images, cannot be characterised as possessing a link with foreign exchange operations. The same applies to the services in Class 36 (para. 26). This is confirmed by the fact that the BoA held that the goods and services covered included ‘in particular software, financial services (especially in connection with foreign exchange operations) and publications’. By using the wording ‘in particular’ and ‘especially’, the BoA implicitly acknowledged that not all the goods and services in question were related to foreign exchange operations (para. 28). As the BoA did not provide any additional statement of reasons for the goods and services that are not characterised by a link with foreign exchange operations, the court held that the BoA had been deficient in providing a statement of reasons (para. 29). The reasoning was limited to the assertion that the combination of the two currency symbols would be perceived as informing the relevant public that the goods and services covered are linked to





foreign exchange operations. Regarding the assessment of the distinctive character of the contested mark, the BoA similarly held that it is difficult to find a more typical designation of an exchange foreign office than the use of the symbol of a popular and / or local currency and that similar symbols were commonly used to illustrate the idea of foreign exchange operations (para. 33). This statement of reasons was not sufficient in relation to the abovementioned goods and services that are not related to foreign exchange operations. Moreover, there are other goods and services covered, for which a link with foreign exchange operations is not obvious (credit and debit card issuance, debit and credit card services, debit and credit card management) (para. 34). The contested decision did not state clearly why the BoA had considered that the mark enabled the relevant public to perceive immediately and without further reflection a description of all the goods and services. This applies in particular to mortgage banking, financial valuation concerning insurance, banking and real estate, and establishing investment funds. For those goods and services, the contested decision did not set out the circumstances to justify the application of Article 7(1)(c) EUTMR. The statement of reasons did not therefore allow the reasoning of the BoA to be followed and, therefore, had to be regarded as insufficient (para. 35). The Office also limited itself to considering that all the goods and services in question were related to foreign exchange operations. However, the Office's decision did not contain any additional statement of reasons regarding the descriptive character of goods and services and as to why all of these were related to foreign exchange operations. Furthermore, it did not provide a better understanding of the reasons why the contested mark must be regarded as consisting of descriptive elements in relation to each of the goods and services covered (para. 38). The BoA decision did not contain any statement of reasons in relation to the goods and services that are not related to foreign exchange operations and which are also covered by the contested mark. The statement of reasons did not explain why the BoA found that all the goods and services were related to foreign exchange operations or why it considered that the sign of the contested mark was descriptive for each of those goods and services. Finally, those deficiencies were not offset by the statement of reasons in the Office's decision. Consequently, the GC found that it was not in a position to review the lawfulness of the contested decision regarding the substance (para. 40). The BoA's finding that the contested mark was devoid of distinctive character pursuant to Article 7(1)(b) EUTMR is based on the descriptive character of the symbols '€' and '\$'. So, the absolute grounds for refusal provided for in Article 7(1)(b) EUTMR has the same lack of statement of reasons as the absolute grounds for refusal referred to in Article 7(1)(c) EUTMR (para. 41). The contested decision must be annulled in its entirety, since one ground is sufficient there is no need to examine the other pleas raised by the applicant (para. 42).

♦[T-60/17](#); **TSA LOCK**; *Safe Skies LLC v EUIPO*; Judgment of 22 March 2018; EU:T:2018:164; Language of the case: EN. The applicant sought to register the word mark **TSA LOCK** as an EUTM for goods and services in Classes 6, 18 and 20. An application for invalidity was filed pursuant to Article 59 EUTMR in conjunction with Article 7(1)(b), (c), (d), (g) and (i) EUTMR. The Cancellation Division (CD) dismissed the application for invalidity. The Board of Appeal (BoA) dismissed the invalidity applicant's appeal. It found, inter alia, that the invalidity applicant had failed to establish that the sign was descriptive or devoid of any distinctive character. In that respect, it held that the relevant date for the purposes of assessing the case was that on which the application for registration of the contested EU trade mark was filed and that none of the evidence was sufficient to prove that, on the relevant date, the sign was perceived by the relevant public as descriptive or devoid of any distinctive character. The invalidity applicant filed an action before the General Court (GC) relying on a single plea in law: infringement of Article 59(1)(a) in conjunction with Article 7(1)(b), (c) and (g) EUTMR. **Descriptiveness**. Although the word 'lock' can be



regarded as descriptive of some goods and services for which this trade mark is registered, it has not been demonstrated that the general public or the relevant specialist public would understand ‘TSA’ as an abbreviation for Transportation Security Administration or as a reference to that American agency (paras 49-50). The use by the applicant on its own website of the expressions ‘tsa luggage locks’ and ‘tsa patented locks’ would only demonstrate its descriptiveness if the public understood the abbreviation TSA, which was not proved to be true (para. 51). Moreover, the adduced discussion threads did not conclusively identify where the contributors are from. Furthermore, only one of those discussion threads pre-dates the relevant date and is written by an author identified as being located in the European Union. The use of the expression ‘tsa lock’ in that item of evidence is not sufficient to make a generalisation as to the understanding of that expression by a significant part of the relevant public (para. 52). The decisions from other trade mark offices cannot be taken into account, in part because of their dates but also because they give no indication as to the relevant public of the European Union (para. 53). The BoA also referred explicitly to all evidence provided (para. 55).

♦[T-207/17](#); **hp (fig.)**; *Senetic S.A. v EUIPO*; Judgment of 24 April 2018; EU:T:2018:396; Language of the case: EN



The intervener applied for an EU trade mark for the figurative mark above for goods and services in Classes 2, 7, 9, 16, 35 to 38 and 40 to 42. The applicant applied for a declaration of invalidity on the basis of Article 59(1)(a) EUTMR, read in conjunction with Article 7(1)(b) and (c) EUTMR, and Article 59(1)(b) EUTMR. The Cancellation Division (CD) dismissed the application in its entirety and the applicant appealed this decision. The Board of Appeal (BoA) dismissed the appeal as it cannot be generally stated that a mark lacks distinctiveness because of any of the following reasons: it consists of one or two letters; the letters ‘hp’ play a dominant role and are not descriptive or lacking in distinctiveness; the applicant did not prove that the contested mark was descriptive or lacking in distinctiveness at the time of registration. The applicant appealed to the General Court (GC) relying on three pleas in law: (i) infringement of Article 59(1)(a) EUTMR, read in conjunction with Article 7(1)(c) EUTMR; (ii) infringement of Article 59(1)(a) EUTMR, read in conjunction with Article 7(1)(b) EUTMR; and (iii) infringement of Article 59(1)(b) EUTMR. **On the first plea in law.** The BoA rightly found that it cannot be generally asserted that a trade mark lacks distinctiveness or is descriptive simply because it consists of one or two letters, without examining the specific relationship between the sign and the goods and services in question (para. 29). The BoA rightly held that (i) some evidence was manifestly irrelevant since it concerned combinations of letters other than those in the contested mark; and (ii) the article *Hedging: The Hidden Face of Credit Hedge Fund Performance*, which says that in the field of financial services the pair of letters ‘hp’ corresponds to ‘hedge process’, ‘hedge programme’ or ‘hedge portfolio’, did not suffice by itself to establish the descriptive character of the contested mark (para. 31). The figurative element, comprising the font and



white letters in a grey circle, only adds to those non-descriptive verbal elements and therefore cannot influence the finding that the contested mark is not descriptive (para. 33).

♦[T-208/17](#); **HP**; *Senetic S.A. v EUIPO*; Judgment of 24 April 2018; EU:T:2018:216; Language of the case: EN. The intervener applied for an EUTM for the word mark **HP** for goods and services in Classes 2, 7, 9, 16, 35 to 38 and 40 to 42. The invalidity applicant filed an invalidity application on the basis of Article 59(1)(a) EUTMR read in conjunction with Article 7(1)(b) and (c) EUTMR. The Cancellation Division (CD) dismissed the invalidity application in its entirety and the applicant appealed this decision. The Board of Appeal (BoA) dismissed the appeal as it cannot be generally stated that a mark lacks distinctiveness because it consists of one or two letters. Further, the letters ‘hp’ play a dominant role and cannot be considered descriptive or lacking distinctiveness. The BoA found that the invalidity applicant had neither proved that the contested mark was descriptive, nor lacking distinctiveness at registration. The EUTM applicant filed an action relying on three pleas in law: (i) infringement of Article 59(1)(a) EUTMR read in conjunction with Article 7(1)(c) EUTMR; (ii) infringement of Article 59(1)(a) EUTMR, read in conjunction with Article 7(1)(b) EUTMR; and, (iii) infringement of Article 59(1)(b) EUTMR. **The first plea in law.** The BoA found that it cannot be generally stated that a trade mark lacks distinctiveness or is descriptive simply because it consists of one or two letters (para. 28). The BoA held that: (i) some evidence was manifestly irrelevant since it concerned combinations of letters other than those in the contested trade mark; and (ii) the article *Hedging: The Hidden Face of Credit Hedge Fund Performance*, according to which the pair of upper-case letters ‘HP’ corresponds in the field of financial services to ‘hedge process’, ‘hedge programme’ or ‘hedge portfolio’, did not suffice by itself to establish the contested mark’s descriptive character (para. 30). The applicant failed to establish a sufficiently direct and specific relationship between the contested mark and the goods and services of that mark. The BoA did not err in finding that, taking account of the very general nature of the arguments and the insufficiency of the evidence produced by the applicant, the CD’s decision could not be annulled (para. 32).

♦[T-187/17](#); **Mega Liner**; *Bernard Krone Holding SE & Co. KG v EUIPO*; Judgment of 4 May 2018; EU:T:2018:254; Language of the case: DE. The applicant sought to register the word mark **Mega Liner** for the goods and services in Classes 12 and 35. The Office refused registration of the trade mark applied for pursuant to Article 7(1)(b) and (c) EUTMR for all the goods and services abovementioned. The applicant appealed against the decision and the Board of Appeal (BoA) partially annulled the Office’s decision for some of the services in Class 35 and dismissed the appeal for the goods in Class 12 and some of the services in Class 35 as it found that the mark applied for was descriptive for those goods and services. The EUTM applicant appealed to the General Court (GC) relying on two pleas in law: (i) infringement of Article 7(1)(c) EUTMR and (ii) infringement of Article 7(1)(b) EUTMR. As the BoA considered that the relevant public was ‘the English-speaking public of the Union’ and examined the meaning of the term ‘liner’ in German, it vitiated the contested decision with a contradiction of reasons (para. 34). None of the sources mentioned in the contested decision were able to establish that the verbal sign in question could designate, in English, the other goods and services in question (para. 37). The BoA did not sufficiently examine the meaning of the term ‘liner’ in English, as claimed by the applicant, and therefore did not assess the perception of the disputed sign by the relevant public as it itself defined it (para. 38). Regarding the term ‘gigaliner’, which would also be understood by the English-speaking public, this statement is not supported by any evidence and the only source mentioned in the contested decision in this respect is an article in German (para. 40). The statement that the relevant public is people whose mother tongue is not English but who have a good command of English, is not supported by any evidence and does not establish



in any way that persons who are fluent in English would understand sources in German (para. 41).

♦♦[T-188/17](#); **Coil Liner**; *Bernard Krone Holding SE & Co. KG v EUIPO*; Judgment of 4 May 2018; EU:T:2018:253; Language of the case: DE. The applicant sought to register the word mark **Coil Liner** for the goods and services in Classes 12 and 35. The Office refused registration of the trade mark applied for pursuant to Article 7(1)(b) and (c) EUTMR for all the goods and services abovementioned. The applicant appealed against the decision and the Board of Appeal (BoA) partially annulled the Office’s decision for the goods in Class 35 and dismissed the appeal for the goods in Class 12 as it found that the mark applied for was descriptive for those goods. The EUTM applicant appealed to the General Court (GC) relying on two pleas in law: (i) infringement of Article 7(1)(c) EUTMR and (ii) infringement of Article 7(1)(b) EUTMR. As the BoA considered that the relevant public was ‘the English-speaking public of the Union’ and examined the meaning of the term ‘liner’ in German, it vitiated the contested decision with a contradiction of reasons (para. 34). None of the sources mentioned in the contested decision allowed to establish that the verbal sign in question could designate, in English, the other goods and services in question (para. 37). The BoA did not sufficiently examine the meaning of the term ‘liner’ in English, as claimed by the applicant, and therefore did not assess the perception of the disputed sign by the relevant public as it itself defined it (para. 38). Regarding the term ‘gigaliner’, which would also be understood by the English-speaking public, this statement is not supported by any evidence and the only source mentioned in the contested decision in this respect is an article in German (para. 40). The statement that the relevant public is people whose mother tongue is not English but who have a good command of English, is not supported by any evidence and does not establish in any way that persons who are fluent in English would understand sources in German (para. 41).

♦♦[T-675/16](#), [T-676/16](#), [T-860/16](#); **mycard2go**; *Wirecard AG v EUIPO*; Judgment of 15 May 2018; EU:T:2018:267; Language of the case: DE

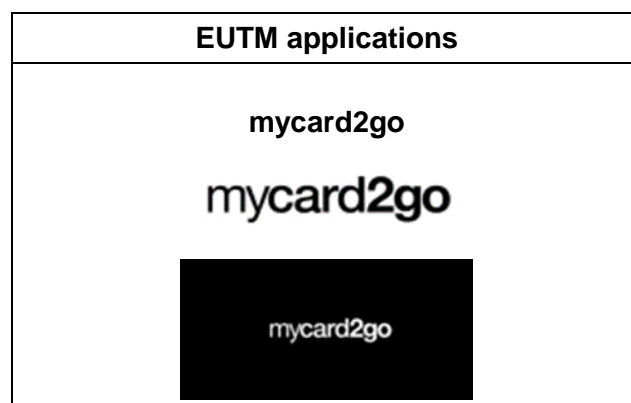

The applicant sought to register the word mark **mycard2go** and the figurative marks shown above as EUTMs for goods and services in, inter alia, Classes 9 and 36. The Office refused the applications pursuant to Article 7(1)(b) and (c) EUTMR, as these were found to be, as a whole, descriptive. The applicant appealed and the Board of Appeal (BoA) dismissed the appeal, finding that the marks were descriptive and non-distinctive. The applicant appealed to the General Court (GC), relying on two pleas in law: (i) infringement of Article 7(1)(b) EUTMR and (ii) infringement of Article 7(1)(c) EUTMR. (i) **Relevant public**. As the contested mark is composed of English words, the assessment must take into account the English-speaking public in the EU (paras 22 and 25). The goods and services target both



the general public and also specialist consumers, such as businesses, with a relatively high level of attention. The services are of a financial nature falling within Class 36 and have a certain economic importance to the consumer because they concern their economic and financial assets (para. 26). **Meaning of the mark.** ‘my’, ‘card’ and ‘go’ are basic English words. The number ‘2’ is often used in advertising as a synonym for ‘to’ (para. 34). Therefore, the sign will be understood immediately, without further considerations, as ‘my card to go’. This means that it is ideal for taking it away to pay for various goods and services. Furthermore, and contrary to what the applicant claims, it cannot be regarded as original or contradictory (paras 34-36). There is a sufficiently direct and specific link between the sign and the goods or services concerned from the point of view of the targeted public (para. 37). Actions were dismissed in cases T-676/16 and T-860/16. However, in T-675/16, the BoA’s decision lacked reasoning regarding the assessment of the link between the mark and the goods and services concerned. This is despite the other parallel decisions being contained in such reasoning (paras 44-45).

♦[T-413/17](#); **3D (fig.)**; *Karl Storz GmbH & Co. KG v EUIPO*; Judgment of 19 June 2018; EU:T:2018:356; Language of the case: EN



The applicant filed for an extension of the international registration (IR) for the figurative sign above for the goods in Classes 9, 10 and 16. The Office refused protection of the IR for these goods on the grounds of Article 7(1)(b) and (c) EUTMR. The applicant appealed the Office’s decision. The Board of Appeal (BoA) dismissed the applicant’s appeal. The applicant appealed to the General Court (GC) relying on two pleas in law: (i) infringement of Article 7(1)(c) EUTMR read in conjunction with Article 94(1) EUTMR and (ii) infringement of Article 7(1)(b) EUTMR. **Descriptiveness.** Even if the expression ‘3D’ is stylised in the sign at issue, it nevertheless remains clearly recognisable. The figurative elements of the sign strengthen the idea of three-dimensionality associated with the expression ‘3D’ and therefore draws the public’s attention towards that idea. Therefore, those elements are entirely incapable of conferring on the sign at issue a meaning different from that established by the BoA, namely that the sign is descriptive with regard to the relevant goods (para. 29). It is highly unlikely that a part of the public would fail to recognise the expression ‘3D’ in the sign at issue (para. 30). The BoA categorised the goods into eight groups and provided general reasoning for each of them (paras 40 and 49). The BoA was entitled to rely on general reasoning with regard to the descriptive nature of the goods falling under groups 1 to 7 (paras 50-73). For the goods in group 8, namely ‘stationery’, the BoA did not sufficiently develop its reasoning to explain how the sign at issue is descriptive (paras 74-75). The first plea in law was rejected, with the exception of the second ground for complaint insofar as it refers to the goods in the eighth group.

♦[C-488/16 P](#); **NEUSCHWANSTEIN**; *Bundesverband Souvenir — Geschenke — Ehrenpreise v EUIPO*; Judgment of 6 September 2018; EU:T:2018:673; Language of the case: DE. The EUTM proprietor registered the word mark **NEUSCHWANSTEIN** as an EUTM for goods and services in Classes 3, 8, 14 to 16, 18, 21, 25, 28, 30, 32 to 36, 38 and 44. An application for invalidity was filed pursuant to Article 59(1)(a) EUTMR in conjunction with Article 7(1)(b) and (c) EUTMR. The Cancellation Division (CD) dismissed the



application for invalidity. This was because firstly, the contested mark did not consist of indications which might serve to indicate the geographical origin or other characteristics of the goods and services concerned. Secondly, it was distinctive for those goods and services, and thirdly, the invalidity applicant did not prove that the EUTM proprietor had acted in bad faith. The Board of Appeal (BoA) confirmed the CD's decision and dismissed the appeal. The invalidity applicant appealed to the General Court (GC), relying on three pleas in law: (i) infringement of Article 7(1)(b) EUTMR (ii) infringement of Article 7(1)(c) EUTMR, (iii) infringement of Article 59(1)(b) EUTMR. The GC rejected the three pleas of the invalidity applicant and dismissed the action in its entirety. The invalidity applicant appealed to the Court of Justice of the European Union (CJ). **Descriptiveness.** The mere fact that the goods and services are offered in a particular place cannot constitute a descriptive indication of the geographical origin of those goods and services, insofar as the place where those goods and services are sold is not capable, as such, of designating characteristics, qualities or distinctive features connected with their geographical origin, such as a craft, a tradition or a climate which are characteristic of a particular place. Neuschwanstein Castle is not famous for the souvenir items it sells or the services it offers, but rather for its unusual architecture (paras 50-51). In the mind of the relevant public, the place where the goods and services are being offered and to which the name 'Neuschwanstein' relates is not, as such, a description of a quality or an essential characteristic of the contested mark's goods and services (para. 53).

♦ [T-93/16](#); **VANGUARD**; *Rheinmetall Waffe Munition GmbH v EUIPO*; Judgment of 10 October 2018; EU:T:2018:671; Language of the case: DE, The IR holder designated the EU for the word mark **VANGUARD** for *projectiles, namely grenades or firecrackers with blast-flash loads and also flashbang (stun) loads for irritation and/or disorientation purposes* in Class 13 and *advertising; distribution of advertising material* in Class 35. The Office refused to protect the mark pursuant to Article 7(1)(b) and (c) EUTMR. The IR holder filed an appeal, which the Board of Appeal (BoA) dismissed. It found that the relevant professional public would understand the term 'vanguard', when affixed to a weapon, as a descriptive message within the meaning of Article 7(1)(b) EUTMR, to the effect that the weapon was intended for use by the part of the armed forces on the front line, or by soldiers, police officers, etc. who occupy the leading position. Furthermore, the term 'vanguard' also refers to a group that is a leader in its field, and is thus laudatory and lacks distinctive character. The IR holder appealed to the General Court (GC), relying on two pleas in law: (i) infringement of Article 7(1)(b) EUTMR and (ii) infringement of Article 7(1)(c) EUTMR. **Descriptiveness.** 'Vanguard' is an English term that designates, first, 'the leading division or the leading units of an army; the foremost part of an advancing army or naval force; the troops at the head of an army' and, second, 'the leading position in a movement or field, or the persons occupying such a position; a group of people leading the way in new developments or ideas; the forefront of an action or movement'. The relevant public for which the descriptive character of the sign must be assessed is the specialised English-speaking professional public of Ireland, Malta and the United Kingdom (paras 26-28). Regarding the first meaning of the term 'vanguard', the Office did not provide any element to support its conclusion that the term referred not only to the (naval, land or air) armed forces but also to police and special forces (para. 34). Furthermore, the BoA equated the goods at issue to weapons without quoting any specialised sources. Furthermore, it did not address the argument put forward by the IR holder that leading units of the armed forces use only weapons in the proper sense of the term, i.e. devices intended to cause injury and damage, and not mere grenades or projectiles that are only for irritation or disorientation and do not inflict injury. To sum up, the BoA did not establish the accuracy of the findings on the basis of which it had concluded that the mark applied for was descriptive (paras 38-40). With the second meaning assumed by the BoA ('the leading position in a movement or



field, or the persons occupying such a position’), the term ‘vanguard’ is, at most, a laudatory term intended to evoke a characteristic that the IR holder might wish to attribute to its own goods and services, without, however, informing the professional public of the objective and specific characteristics of the goods offered. It will be a marketing argument with an evocative rather than a descriptive function (para. 46). The BoA therefore did not sufficiently establish that the mark was descriptive of the goods in Class 13 and the services in Class 35 (para. 51).

♦ [T-120/17](#); **FLUO**. (fig.); *M & T Emporia Ilektrikon-Ilektronikon Eidon AE v EUIPO*; Judgment of 11 October 2018; EU:T:2018:672; Language of the case: EN



The applicant sought to register the figurative mark above as an EUTM for goods in, inter alia, Class 9. The Office refused to register the EUTM application pursuant to Article 7(1)(b) and (c) EUTMR, as it was descriptive and devoid of distinctive character. The applicant filed an appeal. The Board of Appeal (BoA) partially dismissed the appeal and the applicant filed an action with the General Court (GC), relying on two pleas in law: (i) infringement of Article 7(1)(c) EUTMR and (ii) infringement of Article 7(1)(b) EUTMR. **Relevant public.** As the contested mark contained the French word ‘fluo’, the relevant public was the French-speaking public of the EU (para. 27). **Meaning of the mark.** The figurative elements of the contested mark serve clearly and immediately to identify the word ‘fluo’. The font used is a standard, easily legible and unmemorable typeface. In addition, the full stop after the word ‘fluo’ does not alter the meaning of that word (para. 34). The relevant consumer will understand the word ‘fluo’, an abbreviation of the word ‘fluorescent’, as an expression meaning ‘luminous, vivid in colour’ (para. 35). **Link between the mark and the goods.** The BoA did not establish a sufficiently direct and specific relationship between the word ‘fluo’ and the goods (para. 36). The mere fact that screens emit light and colour images is not sufficient to conclude that fluorescent colours are an essential characteristic of the goods. In addition, the colour images on the screens of the goods at issue are not usually fluorescent in the course of the normal operation of those goods (para. 38). The word ‘fluo’ relates, only under certain conditions, to a part of the goods, namely their screens. The fact that a screen may possibly emit fluorescent colours cannot realistically be considered an intrinsic and permanent characteristic of the goods or a part thereof, namely the screens (para. 40). **Lack of descriptiveness.** The word ‘fluo’ does not directly and immediately inform the consumer of one of the characteristics of the goods (para. 41). The BoA did not show that the relevant public would perceive the contested mark, immediately and without further thought, as a description of the goods or one of their characteristics (para. 42). Since the BoA relied solely on the first plea in law in order to refuse registration, there is no need to examine the second plea in law (para. 45).

♦ [T-122/17](#); **DEVIN**; *Devin AD v EUIPO*; Judgment of 25 October 2018; EU:T:2018:719; Language of the case: EN. The EUTM proprietor registered the word mark **DEVIN** as an EUTM for goods in Class 32. An invalidity application was filed pursuant to Article 59(1)(a) EUTMR in conjunction with Article 7(1)(c), (f) and (g) EUTMR. The Cancellation Division (CD) partially upheld the invalidity application regarding Article 7(1)(c) EUTMR. The EUTM proprietor appealed. The Board of Appeal (BoA) dismissed the appeal, insofar as it found



that for a significant part of the relevant Bulgarian public, and the public in the neighbouring countries, the contested mark was descriptive of the geographical origin of the goods covered. The EUTM proprietor filed an action before the General Court (GC), relying on two pleas in law: (i) infringement of Article 59(1)(a) EUTMR in conjunction with Article 7(1)(c) EUTMR and (ii) subsidiarily, infringement of Article 7(3) EUTMR. **Perception of the word ‘devin’ by the average EU consumer.** The BoA erred in focusing on the minimal fraction of those who plan to visit Bulgaria, and above all, the very small fraction of those who visit Devin or do research about it (para. 46). Moreover, the mere fact that the town of Devin has a detectable presence on the internet cannot suffice to establish that it would be known by a significant part of the relevant public of Greece and Romania (para. 39). The evidence adduced shows that the town of Devin does not represent a major attraction for foreign tourists, particularly Greek and Romanian, and, a fortiori, is not known to the average consumer abroad (para. 54). Indeed, from the survey evidence adduced, it can also be concluded that approximately 97 % of the Greek population does not recognise the word ‘devin’ as a ‘town’, ‘place’ or ‘region of Bulgaria’ (para. 58). Therefore, the BoA did not establish that the word ‘devin’ is known as the designation of a geographical origin by the average consumer in Greece and Romania (para. 61). Additionally, it does not appear from the file that the word ‘devin’ is recognised as the designation of a geographical origin by the average consumer in the Member States of the EU other than Bulgaria, in which, admittedly, it has been recognised as having a reputation by the national patent office (paras 35, 67). **The availability of the geographical name Devin.** Devin is a well-defined place, known to the average consumer only in Bulgaria and largely unknown to the average consumer in the rest of the EU, the reputation of which is limited to its waters (para. 82). The name of the town of Devin remains available to third parties not only for descriptive use, such as the promotion of tourism in that town, but also as a distinctive sign in cases of ‘due cause’ and where there is no LOC (para. 89). The general interest in preserving the availability of a geographical name such as that of the spa town of Devin can therefore be protected by allowing descriptive uses of such names and by means of safeguards limiting the exclusive right of the proprietor of the contested mark (para. 90). **Scope of proceedings.** Since the issue of whether distinctive character had been acquired by the use of the contested trade mark in Bulgaria was not clearly examined by the BoA, it is not for the GC to examine it, for the first time, in its review of the legality of the contested decision (para. 98).

##### **5. Customary signs and indications (Article 7(1)(d) EUTMR)**

[No entry]





**C. Article 7(1)(e), 59(1)(a) EUTMR — Shapes or other characteristics with an essentially technical function, substantial value or resulting from the nature of the goods**

**T-44/16; DEVICE OF A SQUARE (fig.);** *Novartis AG v EUIPO*; Judgment of 31 January 2018; EU:T:2018:48; Language of the case: EN

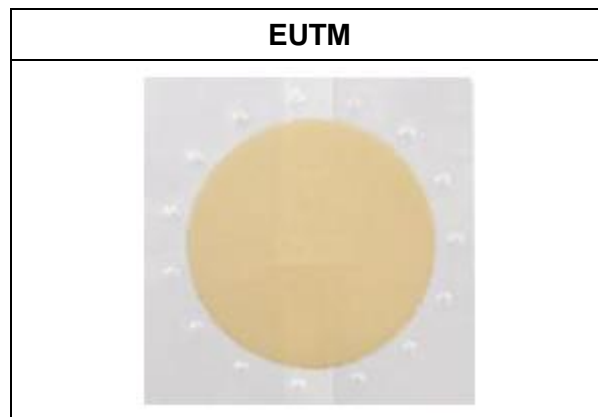

The EUTM proprietor was granted registration of the figurative mark above as an EUTM for goods in Class 5. An application for invalidity was filed pursuant to Article 59(1)(a) EUTMR in conjunction with Article 7(1)(a), (b) and (e) EUTMR. The Cancellation Division (CD) upheld the application for invalidity. Upon the EUTM proprietor's appeal, the Board of Appeal (BoA) dismissed the appeal. It found that the contested mark had to be declared invalid on the ground that it was composed of a sign consisting exclusively of the shape of the product necessary to obtain a technical result. The EUTM proprietor filed an action before the General Court (GC) relying on a single plea in law: infringement of Article 7(1)(e)(ii) EUTMR. Registration as a trade mark of a purely functional product shape is likely to allow the proprietor of that trade mark to prevent other undertakings not only from using the same shape, but also from using similar shapes (para. 40). The function of the specific product may be examined in order to establish the link between what is visible and what could be a technical solution (para. 93). The technical functions identified are technically causal of, and sufficient to obtain, the intended technical result, which is the administration of a medicinal product through a transdermal patch for the treatment of Alzheimer's disease (para. 38): (i) The square shape of the liner serves to package and store the patches, which are packaged in packets, which are in turn stored in rectangular cardboard boxes. The ease of removal is only an additional functionality of the square shape of the patch (paras 37 and 63). (ii) The arrangement of knobs serves to protect the patch prior to use: the circular configuration of the knobs merely follows the round, functional shape of the patch and cannot represent a major non-functional element (paras 37 and 89). The same technical function can be obtained with a different arrangement of the knobs: the condition of necessity does not mean that the shape at issue must be the only one capable of obtaining the technical result (para. 87). (iii) The white stripe represents the overlapping protective plastic layer, which facilitates the application of the patch (para. 37). The functionality of the plastic layer was correctly identified through examination of the function of the product, as well as by the fact that transdermal patches used in the medical field frequently have an overlapping plastic layer on the back with the same function (para. 69). (iv) The circular shape of the patch ensures that it affixes to the skin: application recommendations indicate that the user should avoid it coming loose, and the fact that there are numerous examples of rectangular patches available on the market



that have rounded edges also suggests that a circular shape is less likely to come loose (paras 37 and 78). (v) The beige colour of the circular area of the patch cannot be regarded as an essential characteristic: it is commonly used for transdermal patches and this colour on a product that affixes to the skin is not remarkable. The presence of one or more minor arbitrary elements in a sign does not alter the conclusion that the sign consists exclusively of the shape of goods that is necessary to obtain a technical result (paras 100, 102 and 104). Given that all the essential characteristics of the sign serve a technical result, there is no need for an overall assessment of the sign (para. 52). Even if a sign consisting exclusively of the shape of the product necessary to obtain a technical result has become distinctive through use, it cannot be registered as a mark (para. 57).

**C-163/16; Louboutin and Christian Louboutin; *Christian Louboutin, Christian Louboutin SAS v Van Haren Schoenen BV***; Preliminary ruling of 12 June 2018; EU:C:2018:423; Language of the case: NL. The request for a preliminary ruling was made in the course of infringement proceedings between Christian Louboutin and Christian Louboutin SAS against Van Haren Schoenen BV, concerning the sale by Van Haren of shoes that allegedly infringed the trade mark owned by Mr Louboutin. Mr Louboutin, a designer and producer of shoes, obtained the trade mark registration below from the Benelux Office for Intellectual Property in 2010 for (after amendment) *high-heeled shoes (other than orthopaedic shoes)* in Class 25. In the application for registration, the mark at issue was described as follows: ‘The mark consists of the colour red (Pantone 18-1663TP) applied to the sole of a shoe as shown (the contour of the shoe is not part of the trade mark but is intended to show the positioning of the mark)’.



During 2012, Van Haren, who operate shoe retail outlets in the Netherlands, sold women’s high-heeled shoes with red soles. Christian Louboutin initiated proceedings before the Rechtbank Den Haag (District Court, The Hague, Netherlands) (the referring court), claiming that Van Haren had infringed the mark at issue. The referring court delivered a default judgment partially upholding Christian Louboutin’s claims. Van Haren challenged that judgment claiming that the mark at issue was invalid on the basis of Article 2.1(2) of the Benelux Convention. Van Haren maintains that the mark at issue is a two-dimensional figurative mark that consists of a red coloured surface (para. 13). In that respect, the referring court considered that, having regard to the graphic representation and the description of the mark, the colour red is inextricably linked to the sole of a shoe and, therefore, the mark cannot be regarded merely as a two-dimensional figurative mark (para. 14). Furthermore, in autumn 2012, the referring court noted that a significant proportion of consumers of women’s high-heeled shoes in the Benelux States was able to identify Christian Louboutin shoes as goods originating from that producer, therefore, at that time, the mark at issue was perceived as a trade mark in relation to the goods. Moreover, in the view of the referring court, the red sole gave substantial value to the shoes marketed by



Christian Louboutin since this colour forms part of the appearance of these shoes and plays an important role in a consumer's decision to purchase them (paras 15-16). In this last respect, Article 3(1)(e)(iii) of Directive 2008/95/EC excludes from registration — 'signs which consist exclusively of the shape which gives substantial value to the goods'. Due to all the above, the referring court was uncertain about the validity of the registered Benelux mark and decided to stay the proceedings and to refer the following question to the Court of Justice (CJ) for a preliminary ruling: 'Is the notion of "shape", within the meaning of Article 3(1)(e)(iii) of [Directive 2008/95] (respectively referred to in the German-, English- and French-language versions of [that directive] as "Form", "shape" and "forme"), limited to the three-dimensional properties of the goods, such as their contours, measurements and volume (expressed three-dimensionally), or does it include other (non-three-dimensional) properties of the goods, such as their colour?' The referring court asks, in essence, whether Article 3(1)(e)(iii) of Directive 2008/95/EC must be interpreted as meaning that a sign consisting of a colour applied to the sole of a high-heeled shoe, such as that at issue in the main proceedings, consists exclusively of a 'shape', within the meaning of that provision (para. 19). **Legal notion of 'shape'**. In the absence of any definition of this concept in Directive 2008/95/EC, the settled case-law of the CJ, in conjunction with the usual meaning of the concept in everyday language and in context, should establish the meaning and scope of the term. In the context of trade mark law, a colour per se, without an outline, cannot constitute a 'shape', which is understood as 'a set of lines or contours that outline a given product' (paras 20-22). **Can a colour applied to a specific part of a product result in the sign at issue consisting of a shape within the meaning of the aforementioned provision of the directive?** Although the shape of the product, or of a part of the product, does play a role in creating an outline for the colour, it cannot, however, be held that a sign consists of that shape in the case where the registration of the mark did not seek to protect that shape but sought solely to protect the application of a colour to a specific part of that product (para. 24). The mark at issue does not relate to a specific shape of sole for high-heeled shoes since the description of that mark explicitly states that the contour of the shoe does not form part of the mark and is intended purely to show the positioning of the red colour covered by the registration (para. 25). In any event, a sign, such as that at issue, cannot be regarded as consisting 'exclusively' of a shape since the main element of that sign is a specific colour designated by an internationally recognised identification code (para. 26). In light of the foregoing considerations, the answer to the question referred is that Article 3(1)(e)(iii) of Directive 2008/95/EC must be interpreted as meaning that a sign consisting of a colour applied to the sole of a high-heeled shoe does not consist exclusively of a 'shape', within the meaning of that provision.



♦ [T-447/16](#); **DEVICE OF PIRELLI TYRE TREAD (fig.)**; *Pirelli Tyre SpA v EUIPO*; Judgment of 24 October 2018; EU:T:2018:709; Language of the case: EN

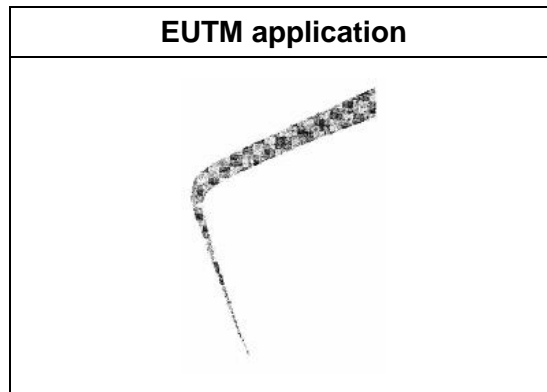

The EUTM proprietor registered the figurative mark above as an EUTM for, inter alia, *tyres, solid, semi-pneumatic and pneumatic tyres for vehicle wheels of all kinds* in Class 12. An invalidity application was filed pursuant to Article 59(1)(a) EUTMR in conjunction with Article 7(1)(e)(ii) EUTMR. The Cancellation Division (CD) upheld the invalidity application for the goods mentioned. It found that the contested sign consisted exclusively of the shape of the goods concerned necessary to obtain a technical result within the meaning of Article 7(1)(e)(ii) EUTMR. The proprietor filed an appeal. The Board of Appeal (BoA) rejected the appeal for the goods mentioned above. It found that the sign represented a tyre tread and, therefore, perhaps the most crucial part of the contested goods, at least from a technical perspective. The proprietor filed an action with the General Court (GC), relying on three pleas in law: i) having based the contested decision on a version of Article 7(1)(e)(ii) EUTMR that was not applicable *ratione temporis*, (ii) procedural irregularities and infringement of the obligation to state reasons, and (iii) infringement of Article 7(1)(e)(ii) EUTMR. **First plea. Applicable version of Article 7(1)(e)(ii)**. Although the BoA wrongly cited the wording of Article 7(1)(e)(ii) of Regulation (EC) No 207/2009 as amended by Regulation (EU) No 2015/2424, whereas the version in force at the time of the EUTM application in 2001 was that of Regulation (EC) No 40/94, when the BoA set out in detail the interpretation of that provision, it mentioned the case-law handed down under Article 7(1)(e)(ii) of Regulation (EC) No 40/94, which refers only to the ‘shape of goods’, several times. In addition, it is apparent from reading the contested decision that the BoA assessed the facts on the basis of the conditions laid down in Article 7(1)(e)(ii) of Regulation (EC) No 40/94, as interpreted by the relevant case-law. Therefore, the BoA did not apply the amendment made by Regulation (EU) No 2015/2424 (‘the shape, or another characteristic, of goods which is necessary to obtain a technical result’) but rather the provision applicable at the time, namely Article 7(1)(e)(ii) of Regulation (EC) No 40/94, which provides for the refusal of registration of ‘signs which consist exclusively of ... the shape of goods which is necessary to obtain a technical result’. The first plea in law must therefore be rejected (paras 24-28). **Third plea. Infringement of Article 7(1)(e)(ii) of Regulation (EC) No 40/94**. The figurative two-dimensional sign which, when abstractly analysed, resembles, for example, the shape of an inclined hockey stick or an inclined ‘L’, clearly does not represent the shape of a tyre, nor that of a tyre tread (paras 48-49). The BoA was permitted to take into account all information making it possible to identify what the shape at issue actually represents, but not to the point of defining the contested sign by including characteristics which the sign as represented does not possess and which it does not cover (paras 56-57). The fact that some of the EUTM proprietor’s tyre models contain a groove in the shape represented by the sign applied for on their tyre tread did not entitle the



BoA to go beyond the contested sign in order to qualify it as ‘a representation of a tyre tread’. In other words, the BoA, by adding elements which do not form part of the contested sign, took the view that the sign represented the shape of the goods in question for which it had been registered (para. 58). The case-law relating to signs which did not have the same characteristics as the contested sign, either because they were three-dimensional signs or because the relevant shapes were defined based on characteristics which were ‘specific’ to the sign at issue or ‘constituent’ of it, does not apply to the present case. This case-law does not authorise the Office to qualify the contested sign as a tyre or as ‘a representation of a tyre tread’ (paras 62-66). Since the assessment of what the contested sign actually represents is a step which allows, firstly, its essential characteristics to be identified, and secondly, any potential functionality of those essential characteristics to be gauged, the fact that the BoA included elements which do not form part of the shape actually represented by the contested sign in its assessment is capable of invalidating the conclusion that the conditions set out in Article 7(1)(e)(ii) of Regulation (EC) No 40/94 are met (para. 67). The contested sign represents a single groove of a tyre tread, which is not a product since it is not a separable element of a tyre. Consequently, the contested sign is not made up exclusively of the shape of the goods in question, nor of a shape which, on its own, represents, quantitatively and qualitatively, a significant part of those goods (paras 68-71). A single groove in the identical shape to that represented by the contested sign is not capable of producing the technical result accepted in the contested decision. The BoA was therefore wrong to take the view that the contested sign represented a tyre tread and therefore consisted of the ‘shape of the goods’ within the meaning of Article 7(1)(e)(ii) of Regulation (EC) No 40/94 (paras 72, 74). Since the first part of the third plea in law relied on by the proprietor must be upheld, there is no need to rule on the second part of the same plea alleging that the essential characteristics of the contested sign do not all have exclusive functionality, nor on the second plea in law (para. 75). The part of the contested BoA decision confirming the declaration of invalidity of the registered mark must therefore be annulled (para. 76).

#### **D. Article 7(1)(f), 59(1)(a) EUTMR — Trade marks contrary to public policy or accepted principles or morality**

**T-69/17; Fack Ju Göhte; Constantin Film Produktion GmbH v EUIPO;** Judgment of 24 January 2018; EU:T:2018:27; Language of the case: DE. The applicant sought to register the word mark **Fack Ju Göhte** as an EUTM for goods and services in Classes 3, 9, 14, 16, 18, 21, 25, 28, 30, 32, 33, 38 and 41. The Office refused the registration of the EUTM application pursuant to Article 7(1)(f) EUTMR, as it was found to be contrary to accepted principles of morality. The applicant appealed and the Board of Appeal (BoA) dismissed the appeal, as it found that the pronunciation of the component ‘Fack ju’ was identical to that of the expression ‘Fuck you’, and therefore meant the same thing. It also concluded that even if the relevant public were not to attribute any sexual connotation to the expression ‘Fuck you’, it was still an insult, and not only tasteless but also offensive and vulgar. Moreover, the fact that the respected German writer Goethe, as well as having his name misspelled, was being posthumously disparaged in such a derogatory and vulgar way might even add an additional layer to the breach of the accepted principles of morality. The applicant filed an action before the General Court (GC), relying on two pleas in law: (i) infringement of Article 7(1)(f) EUTMR and (ii) infringement of Article 7(1)(b) EUTMR. **Relevant public.** German-speaking consumers within the European Union, namely consumers in Germany and Austria (para. 17). The goods and services for which protection is sought primarily target general consumers, while some primarily target children and young people. However, signs caught by this ground of refusal may cause offence not only



to the relevant public but also to other people who encounter the sign by chance in everyday life without being interested in the goods and services specified (para. 15). Likewise, it is not possible to refer to the perception of the part of the relevant public that is easily offended or the perception of the part of that public that is impervious; rather the criteria of a reasonable person with an average sensitivity and tolerance threshold must be taken as a basis (para. 34). **Perception of the sign.** The trade mark application **Fack Ju Göhte** is the phonetic reproduction in German of the expression ‘Fuck you Göhte/Goethe’, the first part of which is easily understood by the general public and the second part of which corresponds to the renowned German writer (para. 17). Even if the first element were deemed not to have any sexual connotation, it still expresses anger, disappointment and contempt. Besides, directing the insult towards a specific person, Goethe in particular, increases rather than mitigates the vulgarity and obscenity of the sign (para. 18). Furthermore, it cannot be inferred from the broad public success of a film of the same name that the relevant public will immediately recognise the film title in the trade mark application and not be offended (para. 40). The contested mark as a whole is intrinsically vulgar and could offend the relevant public (para. 20). **Scope of the proceedings.** As the EUIPO guidelines also confirm, ‘public policy’ and ‘accepted principles of morality’ are two different concepts that often overlap. There is no need to assess separately whether the contested mark is contrary to public order, since it suffices that it was found to be contrary to the principles of morality (paras 23-24). Likewise, there is no need to assess the ground of Article 7(1)(b) EUTMR and the distinctiveness of the mark, as the conditions for at least one absolute ground of refusal have been met (para. 46).

**T-1/17; La Mafia SE SIENTA A LA MESA (fig.); La Mafia Franchises, SL v EUIPO;** Judgment of 15 March 2018; EU:T:2018:146; Language of the case: EN



The EUTM proprietor was granted the registration of the figurative mark above as an EUTM for goods and services in Classes 25, 35 and 43. An application for invalidity was filed pursuant to Article 7(1)(f) EUTMR. The Cancellation Division (CD) upheld the application for a declaration of invalidity and the proprietor appealed against the CD’s decision. The Board of Appeal (BoA) dismissed the appeal, as it confirmed that the contested mark was contrary to public policy. The proprietor filed an action before the General Court (GC) relying on a single plea in law: infringement of Article 59(1)(a) EUTMR, read in conjunction with Article 7(1)(f) EUTMR. The word element ‘la Mafia’, on account of its size and central position in the contested mark, is the dominant element in the contested mark (paras 31 to 32). ‘La Mafia’ refers to a criminal organisation which resorts to intimidation, physical violence and murder in carrying out its activities. Such activities breach the values on which the EU is founded (especially respect for human dignity and freedom). Therefore, ‘la Mafia’



would manifestly bring to mind, for the relevant public, the name of a criminal organisation responsible for particularly serious breaches of public policy (paras 34 to 38). Moreover, the fact that there are many books and films (like the *Godfather*) on the subject of the Mafia in no way alters the perception of the harm caused by that organisation (para. 43). The red rose could be perceived by a large part of the relevant public as the symbol for love or harmony, in contrast to the violence that characterises the Mafia's activities (para. 44). That contrast is accentuated by the sentence 'se sienta a la mesa' in the contested mark. That sentence means 'takes a seat at the table' in Spanish, and may be perceived by a large part of the public as referring to the idea of sharing a meal. Therefore, the association of the Mafia with the ideas of conviviality and relaxation may trivialise the illicit activities of that criminal organisation (paras 45 to 46). Consequently, the GC concludes that the contested mark refers to a criminal organisation, conveys a globally positive image of that organisation and trivialises the serious harm caused by that organisation to the fundamental values of the EU. It is therefore likely to shock or offend not only the victims of that criminal organisation and their families, but also any person who, on EU territory, encounters that mark and has average sensitivity and tolerance thresholds, and must therefore be declared invalid (para. 48).

#### **E. Article 7(1)(g), 59(1)(a) EUTMR — Deceptive trade marks**

♦[T-60/17](#); **TSA LOCK**; *Safe Skies LLC v EUIPO*; Judgment of 22 March 2018; EU:T:2018:164; Language of the case: EN. The applicant sought to register the word mark **TSA LOCK** as an EUTM for goods and services in Classes 6, 18 and 20. An application for invalidity was filed pursuant to Article 59 EUTMR in conjunction with Article 7(1)(b), (c), (d), (g) and (i) EUTMR. The Cancellation Division (CD) dismissed the application for invalidity. The Board of Appeal (BoA) dismissed the invalidity applicant's appeal. It found, inter alia, that the invalidity applicant had failed to establish that the sign was descriptive or devoid of any distinctive character. In that respect, it held that the relevant date for the purposes of assessing the case was that on which the application for registration of the contested EU trade mark was filed and that none of the evidence was sufficient to prove that, on the relevant date, the sign was perceived by the relevant public as descriptive or devoid of any distinctive character. The invalidity applicant filed an action before the General Court (GC) relying on a single plea in law: infringement of Article 59(1)(a) in conjunction with Article 7(1)(b), (c) and (g) EUTMR. **Deceptiveness**. It cannot be held that the public will be misled as to the origin of the goods bearing the contested mark, since the sign will have no association in the public consciousness with a particular origin. It has not been proved that 'tsa lock' will be understood in the relevant territory as a reference to the American Transportation Security Administration (para. 64).

♦[T-419/17](#); **VSL#3**; *Mendes SA v EUIPO*; Judgment of 18 May 2018; EU:T:2018:282; Language of the case: IT. The EUTM proprietor obtained registration of the word mark **VSL#3** as an EUTM for goods in Class 5. An application for revocation was filed pursuant to Article 58(1)(b) and (c) EUTMR. The Cancellation Division (CD) dismissed the application for revocation. The Board of Appeal (BoA) dismissed the revocation applicant's appeal. It found that the revocation applicant had neither provided sufficient evidence to demonstrate that the sign had become the common name in trade of the goods for which it was registered, nor did it prove that the sign was liable to mislead the public concerning the nature or quality of the goods. The revocation applicant filed an action before the General Court (GC) relying on two pleas in law: infringement of Article 58(1)(b) and (c) EUTMR. **Relevant public**. The relevant circles for probiotic preparation for treating gastrointestinal disorders marketed under the contested mark include, in addition to pharmacists and



doctors, the end consumers, given that the product does not require a medical prescription. The scientific community is not part of the relevant circles, playing no role in the communication process between the vendor and the purchaser (para. 40). **Deceptive element.** Given that the mark is not the common name in the trade for the product and that it contains no descriptive indication of that product or of its characteristics, it is not capable of giving rise to actual deceit or a sufficient risk that would deceive the consumer (para. 57).

♦[T-681/17](#); **KHADI / KHADI**; *Khadi and Village Industries Commission v EUIPO*; Judgment of 29 November 2018; EU:T:2018:858; Language of the case: EN. The EUTM proprietor registered the word mark **KHADI** as an EUTM for goods in Classes 3, 21 and 31. An invalidity application was filed pursuant to Article 59(1)(b) EUTMR, Article 59(1)(a) EUTMR in conjunction with Article 7(1)(g) and (i) EUTMR, Article 60(1)(a) EUTMR in conjunction with Article 8(1)(a) and (b) EUTMR, and Article 60(1)(c) EUTMR in conjunction with Article 8(4) EUTMR. The Cancellation Division (CD) dismissed the invalidity application. The invalidity applicant filed an appeal. The Board of Appeal (BoA) dismissed the appeal. It found that the applicant had not adduced proof of any of the grounds of invalidity relied on. The invalidity applicant filed an action with the General Court (GC), relying on five pleas in law: (i) infringement of Article 95(2) EUTMR, (ii) distortion of the evidence, (iii) infringement of Article 7(1)(g) and Article 59(1)(a) EUTMR, (iv) infringement of Article 7(1)(g) and Article 59(1)(a) EUTMR and (v) infringement of Article 59(1)(b) EUTMR. **Submission of items of evidence for the first time before the BoA.** Since the special rule contained in the third subparagraph of Rule 50(1) of Regulation 2868/95, which allows the BoA to take into account additional and supplementary facts and evidence in certain cases, refers only to opposition proceedings, the BoA erred in concluding that it applied to these invalidity proceedings based on both relative and absolute invalidity grounds. However, that error has no effect on the lawfulness of the contested decision, as the BoA examined the nature and the content of the evidence and concluded it was not relevant to the outcome of the case, before finding it to be inadmissible in the exercise of its discretion (paras 22-25). **Distortion of evidence.** The invalidity applicant has failed to provide proof of the distortion of evidence by the BoA (paras 33-36). **Deceptiveness.** None of the invalidity applicant's evidence or arguments permit the inference that the general public, or even the part of the United Kingdom population that is of Indian origin, is generally familiar with the term 'khadi' or its role for Indian industry and, consequently, the BoA rightly assessed that the term is an uncommon word and that it cannot be assumed that the term will be understood by that public. If the relevant public does not associate the term 'khadi' with any specific meaning, the existence of actual deceit or a sufficiently serious risk that the consumer will be deceived cannot be established (paras 48-53).





♦[T-682/17](#); **khadi Naturprodukte aus Indien (fig.) / KHADI et al.**; *Khadi and Village Industries Commission v EUIPO*; Judgment of 29 November 2018; EU:T:2018:856; Language of the case: EN



The EUTM proprietor registered the figurative mark above as an EUTM for, inter alia, goods in Class 3. An invalidity application was filed pursuant to Article 59(1)(b) EUTMR, Article 59(1)(a) EUTMR in conjunction with Article 7(1)(g) and (i) EUTMR, Article 60(1)(a) EUTMR in conjunction with Article 8(1)(a) and (b) EUTMR, and Article 60(1)(c) EUTMR in conjunction with Article 8(4) EUTMR. The Cancellation Division (CD) dismissed the invalidity application. The invalidity applicant filed an appeal. The Board of Appeal (BoA) dismissed the appeal. It found that the applicant had not adduced proof of any of the grounds of invalidity relied on. The invalidity applicant filed an action with the General Court (GC), relying on four pleas in law: (i) infringement of Article 95(2) EUTMR, (ii) distortion of the evidence, (iii) infringement of Article 7(1)(g) and Article 59(1)(a) EUTMR, and (iv) infringement of Article 59(1)(b) EUTMR. **Submission of items of evidence for the first time before the BoA.** Since the special rule contained in the third subparagraph of Rule 50(1) of Regulation 2868/95, which allows the BoA to take into account additional and supplementary facts and evidence in certain cases, refers only to opposition proceedings, the BoA erred in concluding that it applied to these invalidity proceedings based on both relative and absolute invalidity grounds. However, that error has no effect on the lawfulness of the contested decision, as the BoA examined the nature and the content of the evidence and concluded it was not relevant to the outcome of the case, before finding it to be inadmissible in the exercise of its discretion (paras 22-25). **Distortion of evidence.** The invalidity applicant has failed to provide proof of the distortion of evidence by the BoA (paras 33-36). **Deceptiveness.** None of the invalidity applicant's evidence or arguments permit the inference that the general public, or even the part of the United Kingdom population that is of Indian origin, is generally familiar with the term 'khadi' or its role for Indian industry and, consequently, the BoA rightly assessed that the term is an uncommon word and that it cannot be assumed that the term will be understood by that public. If the relevant public does not associate the term 'khadi' with any specific meaning, the existence of actual deceit or a sufficiently serious risk that the consumer will be deceived cannot be established (paras 48-53).

♦[T-683/17](#); **Khadi Ayurveda / KHADI et al.**; *Khadi and Village Industries Commission v EUIPO*; Judgment of 29 November 2018; EU:T:2018:860; Language of the case: EN. The EUTM proprietor registered the word mark **Khadi Ayurveda** as an EUTM for, inter alia, goods in Class 3. An invalidity application was filed pursuant to Article 59(1)(b) EUTMR, Article 59(1)(a) EUTMR in conjunction with Article 7(1)(g) and (i) EUTMR, Article 60(1)(a) EUTMR in conjunction with Article 8(1)(a) and (b) EUTMR, and Article 60(1)(c) EUTMR in conjunction with Article 8(4) EUTMR. The Cancellation Division (CD) dismissed the invalidity application. The invalidity applicant filed an appeal. The Board of Appeal (BoA) dismissed the appeal. It found that the applicant had not adduced proof of any of the



grounds of invalidity relied on. The invalidity applicant filed an action with the General Court (GC), relying on four pleas in law: (i) infringement of Article 95(2) EUTMR, (ii) distortion of the evidence, (iii) infringement of Article 7(1)(g) and Article 59(1)(a) EUTMR, and (iv) infringement of Article 59(1)(b) EUTMR. **Submission of items of evidence for the first time before the BoA.** Since the special rule contained in the third subparagraph of Rule 50(1) of Regulation 2868/95, which allows the BoA to take into account additional and supplementary facts and evidence in certain cases, refers only to opposition proceedings, the BoA erred in concluding that it applied to these invalidity proceedings based on both relative and absolute invalidity grounds. However, that error has no effect on the lawfulness of the contested decision, as the BoA examined the nature and the content of the evidence and concluded it was not relevant to the outcome of the case, before finding it to be inadmissible in the exercise of its discretion (paras 22-25). **Distortion of evidence.** The invalidity applicant has failed to provide proof of the distortion of evidence by the BoA (paras 33-36). **Deceptiveness.** None of the invalidity applicant's evidence or arguments permit the inference that the general public, or even the part of the United Kingdom population that is of Indian origin, is generally familiar with the term 'khadi' or its role for Indian industry and, consequently, the BoA rightly assessed that the term is an uncommon word and that it cannot be assumed that the term will be understood by that public. If the relevant public does not associate the term 'khadi' with any specific meaning, the existence of actual deceit or a sufficiently serious risk that the consumer will be deceived cannot be established (paras 48-53).

#### F. Article 7(1)(h) and (i), 59(1)(a) EUTMR — Trade marks in conflict with flags and other symbols

♦[T-681/17](#); **KHADI / KHADI**; *Khadi and Village Industries Commission v EUIPO*; Judgment of 29 November 2018; EU:T:2018:858; Language of the case: EN. The EUTM proprietor registered the word mark **KHADI** as an EUTM for goods in Classes 3, 21 and 31. An invalidity application was filed pursuant to Article 59(1)(b) EUTMR, Article 59(1)(a) EUTMR in conjunction with Article 7(1)(g) and (i) EUTMR, Article 60(1)(a) EUTMR in conjunction with Article 8(1)(a) and (b) EUTMR, and Article 60(1)(c) EUTMR in conjunction with Article 8(4) EUTMR. The Cancellation Division (CD) dismissed the invalidity application. The invalidity applicant filed an appeal. The Board of Appeal (BoA) dismissed the appeal. It found that the applicant had not adduced proof of any of the grounds of invalidity relied on. The invalidity applicant filed an action with the General Court (GC), relying on five pleas in law: (i) infringement of Article 95(2) EUTMR, (ii) distortion of the evidence, (iii) infringement of Article 7(1)(g) and Article 59(1)(a) EUTMR, (iv) infringement of Article 7(1)(g) and Article 59(1)(a) EUTMR and (v) infringement of Article 59(1)(b) EUTMR. **Prohibition of marks which include badges, emblems or escutcheons of particular public interest.** Since the evidence submitted by the applicant is insufficient to allow it to be concluded that the relevant public will attribute any meaning to the term 'khadi' or would associate it with any organisation whatsoever, the BoA rightly concluded that no badge, emblem or escutcheon would be identified by that public in the sign at issue (para. 61).

#### G. Article 7(1)(j), (k), (l) and (m), 59(1)(a) EUTMR — Trade marks in conflict with geographical indications, traditional terms for wines, traditional specialities guaranteed and earlier plant variety denominations

[C-44/17](#); **SCOTCH WHISKY**; *Scotch Whisky Association v Michael Klotz*, Preliminary ruling of 7 June 2018; EU:C:2018:415; Language of the case: DE. The request for a preliminary



ruling was made in the course of proceedings between the Scotch Whisky Association and Mr Michael Klotz, an online distributor of whisky, concerning an action seeking an order that Mr Klotz cease to market a whisky produced in Germany under the designation 'Glen Buchenbach'. Mr Klotz markets, via a website, a whisky under the designation 'Glen Buchenbach', which is produced by the Waldhorn distillery in Berglen, located in the Buchenbach valley in Swabia (Germany). The label on the whisky bottles in question includes, in addition to a stylised depiction of a hunting horn (Waldhorn in German), the following information: 'Waldhornbrennerei' (Waldhorn distillery), 'Glen Buchenbach', 'Swabian Single Malt Whisky', '500 ml', '40 % vol', 'Deutsches Erzeugnis' (German product), 'Hergestellt in den Berglen' (produced in Berglen). The Scotch Whisky Association brought an action before the Landgericht Hamburg (Regional Court, Hamburg, Germany) seeking an order that Mr Klotz, inter alia, cease to market that whisky, which is not Scotch whisky, under the designation 'Glen Buchenbach', on the ground that use of that designation infringes, in particular, Article 16(a) to (c) of Regulation (EC) No 110/2008, which protects the geographical indications registered in Annex III to that regulation, including 'Scotch Whisky'. According to the Scotch Whisky Association, those provisions ensure that a geographical indication registered for a spirit drink is protected not only against the use of such an indication but also against any reference that suggests the geographical origin of that indication. It argues that because the designation 'Glen' is very widely used in Scotland instead of the word 'valley' and, in particular, as an element of the trade mark in the names of Scottish whiskies, it evokes in the relevant public an association with Scotland and Scotch Whisky despite the fact that other information is included on the label, which specifies that the product at issue is of German origin. The Landgericht Hamburg (Regional Court, Hamburg) states that whether the claim is to succeed depends on the interpretation of Article 16(a) to (c) of Regulation (EC) No 110/2008 which reads as follows: '... the geographical indications registered in Annex III shall be protected against: (a) any direct or indirect commercial use in respect of products not covered by the registration insofar as those products are comparable to the spirit drink registered under that geographical indication or insofar as such use exploits the reputation of the registered geographical indication; (b) any misuse, imitation or evocation, even if the true origin of the product is indicated or the geographical indication is used in translation or accompanied by an expression such as 'like', 'type', 'style', 'made', 'flavour' or any other similar term; (c) any other false or misleading indication as to the provenance, origin, nature or essential qualities on the description, presentation or labelling of the product liable to convey a false impression as to its origin.' It has therefore decided to stay the proceedings and refer three questions to the Court of Justice for a preliminary ruling. **First question.** Does 'indirect commercial use' of a registered geographical indication of a spirit drink in accordance with Article 16(a) of Regulation (EC) No 110/2008 require that the registered geographical indication be used in identical or phonetically and/or visually similar form, or is it sufficient that the disputed element evokes in the relevant public some kind of association with the registered geographical indication or the geographical area? If the latter is sufficient: when determining whether there is any 'indirect commercial use', does the context in which the disputed element is embedded then also play a role, or is the context unable to counteract indirect commercial use of the registered geographical indication, even if the disputed element is accompanied by an indication of the true origin of the product? **Ruling of the CJ.** The disputed element must be used in a form that is either identical to that indication or phonetically and/or visually similar to it. Accordingly, it is not sufficient that said element is liable to evoke in the relevant public some kind of association with the indication concerned or the geographical area. Given the answer to the first part of the question, there is no need to answer the second part. **Second question.** Does an 'evocation' of a registered geographical indication in accordance with Article 16(b) of Regulation (EC) No 110/2008 require that there be a phonetic and/or visual similarity between the registered geographical



indication and the disputed element, or is it sufficient that the disputed element evokes in the relevant public some kind of association with the registered geographical indication or the geographical area? If the latter is sufficient: when determining whether there is any ‘evocation’, does the context in which the disputed element is embedded also play a role, or is the context unable to counteract any unlawful evocation of the registered geographical indication, even if the disputed element is accompanied by an indication of the true origin of the product? **Ruling of the CJ.** To establish that there is an ‘evocation’ of a registered geographical indication, the referring court is required to determine whether, when the average European consumer who is reasonably well informed and reasonably observant and circumspect encounters the disputed designation, the image triggered directly in his mind is that of the product whose geographical indication is protected. In making that determination, the referring court, in the absence of (i) any phonetic and/or visual similarity between the disputed designation and the protected geographical indication and (ii) any partial incorporation of that indication in that designation, must take account of the conceptual proximity, if any, between the designation and the indication. To establish that there is an ‘evocation’ of a registered geographical indication, account is not to be taken either of the context surrounding the disputed element, or, in particular, of the fact that said element is accompanied by an indication of the true origin of the product concerned. **Third question.** When determining whether there is any ‘other false or misleading indication’ in accordance with Article 16(c) of Regulation (EC) No 110/2008, does the context in which the disputed element is embedded play a role, or is the context unable to counteract any misleading indication, even if the disputed element is accompanied by an indication of the true origin of the product? **Ruling of the CJ.** To establish that there is a ‘false or misleading indication’, as prohibited by that provision, the context in which the disputed element is used is not to be taken into account.

**T-774/16; CAVE DE TAIN (fig.); Consejo Regulador del Cava v EUIPO;** Judgment of 12 July 2018; EU:T:2018:441; Language of the case: EN

EUTM application	Earlier PDO
	<p style="text-align: center;">CAVA</p>

The EUTM proprietor obtained registration of the figurative mark above as an EUTM for *wines with a registered designation of origin*, and *vin de pays* in Class 33. An invalidity application was filed pursuant to Article 59(1)(a) EUTMR in conjunction with Article 7(1)(j) EUTMR, read together with Article 103(2)(b) of Regulation No 1308/2013. The latter refers to the misuse, imitation and evocation of a protected designation of origin (PDO). The Cancellation Division (CD) rejected the invalidity application as the signs were not visually or phonetically similar and the contested mark did not evoke the PDO **CAVA**. The Board of



Appeal (BoA) dismissed the invalidity applicant's appeal, finding that the mark did not bring to mind the PDO. The invalidity applicant appealed to the General Court (GC), claiming that the decision be annulled in part insofar as it did not invalidate the contested mark with regard to *sparkling wines with a registered designation of origin*. The invalidity applicant relied on a single plea in law, alleging infringement of Article 59(1)(a) EUTMR in conjunction with Articles 102(1)(b) and 103(2)(b) of Regulation No 1308/2013. **Essential function of a PDO.** The essential function of a PDO is to guarantee to consumers the geographical origin of goods and their inherent special qualities. This does not alter the fact that a PDO identifies a product on the basis of a specific geographical origin, where particular qualities or characteristics are attributable to that origin (para. 35). **CAVA as a reference to geographical area.** The PDO **CAVA** refers to a geographical area consisting of several non-contiguous provinces within Spain. This forms, under the PDO rules, a whole possessed of unity, giving the goods from those provinces an identity based both on a particular geographical environment and on the qualities or characteristics unique to that area (para. 31). **Visual comparison of the signs.** The particular features of the contested mark result in a very specific appearance, meaning that there is a low degree of visual similarity between the two signs (paras 44-49). **Phonetic comparison of the signs.** There is a low degree of phonetic similarity. While the signs have the initial syllable 'ca' in common, followed by a syllable starting with the consonant 'v', this is largely offset by the aural differences arising from the respective number of syllables (seven and two) and phonemes (seven and four). This influences the respective rhythm of pronunciation and intonation used when the signs are pronounced (paras 50-52). **Evocation of the PDO.** 'Cave' is commonly used in the wine sector, whether or not the wine is a sparkling wine (para. 88). Further, considered as a whole, 'cave', 'de' and 'tain' are French-sounding. Therefore, those words would be understood by consumers as referring to a wine cellar in France (para. 92). The contested mark will be understood by consumers regardless of their language, as referring to a wine produced in a French region or town that appears in that mark, irrespective of whether this wine is sparkling or not. Furthermore, the association made by the consumer between the product and its French origin precludes any possible evocation of the PDO **CAVA** (paras 91-95).

#### H. Article 7(3), 59(2) EUTMR — Acquired distinctiveness through use

♦[T-213/17](#); **ROMANTIK**; *Romantik Hotels and Restaurants AG v EUIPO*; Judgment of 25 April 2018; EU:T:2018:25; Language of the case: DE. The EUTM proprietor was granted the registration of the word mark **ROMANTIK** as an EUTM for services in Classes 39 and 43. An application for invalidity was filed pursuant to Article 7(1)(a) to (d) and (g) EUTMR in conjunction with Article 59(1)(b) EUTMR. The Cancellation Division (CD) partly upheld the application for invalidity. The Board of Appeal (BoA) dismissed the EUTM proprietor's appeal. It found that not only the German-speaking public, but also that in Ireland, the Netherlands, Sweden and the United Kingdom would perceive the word 'romantik' as a laudatory and a descriptive message in relation to the services. It also found that the EUTM proprietor had not proved that the word had acquired distinctiveness through the use made of it. The proprietor appealed to the General Court (GC) relying on two plea(s) in law: (i) the mark is endowed with the minimum distinctive character required, and (ii) the mark has acquired distinctive character through the use made of it in the marketplace. **Distinctiveness acquired through use.** The fact that the word mark will be understood in Ireland, the Netherlands, Sweden and the United Kingdom obliges the proprietor claiming that its mark has acquired distinctiveness by use to prove that such is the case in all the territories mentioned (para. 52). A survey on a complex figurative mark does not have probative force in relation to a verbal mark consisting of one word included in that complex



mark. A survey meant to prove the acquired distinctiveness of a mark must be conducted with the specific aim of determining whether the relevant public perceives that mark as the trade mark of a given company (para. 56). Evidence and arguments submitted for the first time before the Court are considered, respectively, inadmissible and not submitted. Specifically, the reference made by the EUTM proprietor to the various submissions made by it before the EUIPO cannot be considered (paras 62-66).

♦[T-463/17](#); **RAISE**; *Raise Conseil v EUIPO*; Judgment of 3 May 2018; EU:T:2018:249; Language of the case: FR. The EUTM proprietor registered the word mark **RAISE** for goods and services in Classes 16, 35, 36 and 41. An application for invalidity was filed pursuant to Article 59(1)(a) EUTMR in conjunction with Article 7(1)(b) to (d) EUTMR. The Cancellation Division (CD) partially upheld the application for invalidity insofar as it found that the mark lacked distinctiveness regarding financial services. The EUTM proprietor appealed, but the Board of Appeal (BoA) dismissed the EUTM proprietor's appeal, finding that the mark would be perceived as a promotional and laudatory message since it designates an activity aimed at increasing financial wealth and value and developing the financial potential of clients and/or fundraising. The EUTM proprietor appealed to the General Court (GC), relying on three pleas in law: (i) infringement of Article 6 ECHR, (ii) infringement of Article 59(1)(a) EUTMR in conjunction with Article 7(1)(b) EUTMR, and (iii) infringement of Article 59(2) EUTMR in conjunction with Article 7(3) EUTMR. The EUTM proprietor failed to demonstrate that the mark had become distinctive through use for the English-speaking public, since most of the evidence submitted is written in French and relates only to France (paras 80-82).

♦[T-78/17](#); **JUMBO**; *Jumbo Africa, S.L. v EUIPO*; Judgment of 26 June 2018; EU:T:2018:383; Language of the case: ES. The EUTM proprietor registered the word mark **JUMBO** as an EUTM for goods in Classes 29 and 30. An application for invalidity was filed pursuant to Article 59(1)(a) EUTMR in conjunction with Article 7(1)(b) and (c) EUTMR. The Cancellation Division (CD) upheld the invalidity application insofar as it found that the term 'jumbo' was descriptive of the goods covered, at least for the English-speaking public of the EU, and that insufficient proof had been adduced regarding the distinctiveness acquired by use. The EUTM proprietor appealed. The Board of Appeal (BoA) dismissed the appeal. It found that the expression 'jumbo' was a direct and obvious reference to the quantity and nature of the relevant foodstuffs, and there was nothing about the mark to suggest that it was unusual or might have its own meaning. Furthermore, the EUTM proprietor had neither claimed nor provided evidence that the trade mark applied for had acquired distinctiveness or had even been used in a substantial part of the EU where English was understood. The EUTM proprietor appealed to the General Court (GC), relying on two pleas in law: (i) infringement of Article 7(1)(b) EUTMR in conjunction with Article 59(1)(a) EUTMR and (ii) infringement of Article 7(3) EUTMR in conjunction with Article 59(2) EUTMR. **Distinctiveness acquired by use.** Registrations in other territories and in nearly all African countries do not have any impact on the case because they do not bind the Office (para. 51). The affidavits signed by the legal representative of Pasa Africa (the previous EUTM proprietor) regarding sales and investments in Spain, France and the United Kingdom cannot have the same reliability and credibility as declarations coming from third persons or persons independent of that company, thus being merely circumstantial evidence that would need to be corroborated by other evidence (para. 56). Furthermore, Spain and France are not territories with an English-speaking public, and in any case, it is not proved that the documents adduced refer to the English-speaking public of the two abovementioned countries (para. 54). What is more, none of the evidence or arguments submitted leads to the conclusion that the contested mark has acquired distinctiveness through use in Ireland, Cyprus or Malta (para. 53). **Paris convention.** The provisions of the



Paris Convention cannot be relied on directly here. Where the EU legislature considered it necessary to give certain provisions of the Paris Convention direct effect, it expressly referred to them in the relevant articles of the EUTMR. However, Article 7(1) EUTMR makes no such reference in relation to the distinctive character of trade marks (para. 29).

♦[T-222/14 RENV](#); **deluxe (fig.)**; *Deluxe Entertainment Services Group Inc v EUIPO*; Judgment of 4 July 2018; EU:T:2015:364; Language of the case: ES. The applicant sought to register the figurative mark ‘deluxe’ as an EUTM for goods and services in Classes 9, 35, 37, 39, 40, 41, 42 and 45. The Office refused to register the mark for all the goods and services on the grounds of Article 7(1)(b) and (c) EUTMR. The Board of Appeal (BoA) dismissed the applicant’s appeal. It found that the mark was devoid of any distinctive character and that the claimed acquired distinctiveness of the mark through its use had not been proven. The applicant filed an action before the General Court (GC) relying on five pleas in law. The GC annulled the contested decision of the BoA on the grounds that the BoA neither carried out the specific assessment required in Article 7(1)(b) EUTMR nor justified its decision for each of the goods and services. The Office lodged an action before the Court of Justice of the European Union (CJ). The CJ annulled the GC’s decision and remitted the case to the GC for further assessment. **Article 7(3) EUTMR**. The court observes that the evidence, submitted by the applicant before the BoA, concerns not only the use of the trade mark applied for, but also the use of two other EU trade marks owned by the applicant (paras 88-89). The evidence submitted in relation to the mark applied for does not serve to establish that the mark applied for had acquired distinctive character through use at the time of the application (para. 96). The sworn declaration was issued by a person linked to the applicant. Its content cannot determine the extent to which the relevant public was in contact with the mark, and it is not corroborated by the additional evidence (paras 91-94). Although, according to earlier case-law, the acquisition of distinctive character by a trade mark may result both from the use, as a part of a registered mark, of an element thereof, and from the use of a different mark in combination with a registered trade mark, neither situation is applicable to this case. Therefore, the BoA did not err by not taking into account the evidence concerning one of the other two marks (paras 97-98). In any case, even assuming that the earlier case-law was applicable to this case, the evidence concerning these other EU marks does not prove that, as a consequence of their use, the relevant public perceives the goods and services designated by the mark applied for as originating from the applicant (paras 99-101).

♦[C-84/17 P](#), [C-85/17 P](#) and [C-95/17 P](#) (joined cases); **SHAPE OF A FOUR FINGER CHOCOLATE BAR (3D mark)**; *Mondelez UK Holdings & Services Ltd v EUIPO — Société des produits Nestlé SA*; Judgment of 25 July 2018; EU:C:2018:596; Language of the case: EN. The EUTM proprietor was granted registration of the three-dimensional mark ‘SHAPE OF A FOUR FINGER CHOCOLATE BAR’ as an EUTM for goods in Class 30. An application for invalidity was filed pursuant to Article 59 EUTMR in conjunction with Article 7(1)(b) EUTMR. The Cancellation Division (CD) upheld the application insofar as the mark was devoid of any distinctive character. The Board of Appeal (BoA) upheld the EUTM proprietor’s appeal. It found that although the mark was devoid of any inherent distinctive character, it had acquired this character through use. The invalidity applicant appealed to the General Court (GC). The GC annulled the BoA’s decision in its entirety, as it found that the BoA did not correctly assess the mark’s distinctive character acquired through use, since it had not adjudicated on the relevant public’s perception of the mark in, inter alia, Belgium, Greece, Ireland and Portugal, and had failed to analyse the evidence submitted by the EUTM proprietor with regard to those Member States. The invalidity applicant appealed to the Court of Justice (CJ). **Distinctiveness acquired by use**. Although it would be unreasonable to require proof of acquired distinctiveness through use for each and every



individual Member State (para. 77), it is not sufficient to prove that the mark has acquired distinctive character through use in a significant part of the EU (para. 78). There is a distinction to be made between the facts to be proved, namely the acquisition of distinctive character through use, and the means of proving such facts (para. 79). Although it is not necessary that evidence be submitted for each individual Member State, the evidence must at least be capable of establishing such acquisition throughout the Member States of the EU (para. 83). The distinctive character acquired through use must be shown throughout the European Union, not only in a substantial part or majority of its territory. Consequently, although such proof may be submitted globally for all the Member States concerned, or separately for different Member States or groups of Member States, it is not sufficient that the party with the burden of providing such evidence merely submits evidence of the acquisition that does not cover part of the European Union, even a part consisting of only one Member State (para. 87). The BoA erred in finding that the mark had acquired distinctive character through use without adjudicating on the perception of that mark in Belgium, Ireland, Greece and Portugal (para. 88).

♦[C-547/17 P](#); **RAPPRESENTAZIONE DI TRE STRISCE VERTICALI (fig.)**; *Basic Net SpA v EUIPO*; Judgment of 6 September 2018; EU:T:2018:682; Language of the case: IT

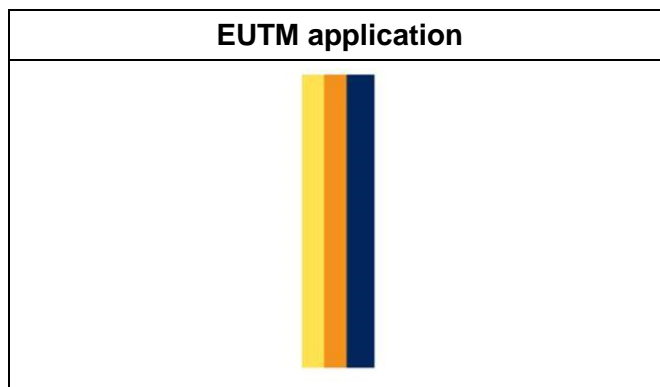

The applicant sought to register the mark above as an EUTM for goods in Classes 18, 25 and 26. The mark was identified in the application form as a figurative mark that claimed three shades of yellow, orange and blue Pantone colours. The Office refused registration of the EUTM application pursuant to Article 7(1)(b) EUTMR. The Board of Appeal (BoA) dismissed the applicant’s appeal. It found that the mark was devoid of distinctive character and that the applicant had not proved acquisition by that mark of a distinctive character through use. The applicant appealed to the General Court (GC), relying on two pleas in law: (i) infringement of Article 7(1)(b) EUTMR and (ii) infringement of Article 7(3) EUTMR. The GC dismissed the appeal. It found that, first, the mark was devoid of any distinctive character and, second, that the acquisition by the mark of a distinctive character had only been proved for France, Italy, the Netherlands and the United Kingdom. For Belgium, Germany, Spain and Austria, the applicant had provided as evidence of use a sworn declaration mentioning turnover and sales data for goods marketed under the disputed mark, but no other evidence to corroborate it. The applicant appealed to the Court of Justice of the European Union (CJ). In support of its appeal, the opponent relies, primarily, on a single plea, alleging infringement of Article 7(3) EUTMR and the obligation to state reasons. In the alternative, it puts forward three other pleas alleging infringement of Article 7(1)(b) EUTMR, failure to take account of another EUTM belonging to it and failure to take into consideration other registered marks consisting of combinations of colours, respectively. **Member states in which a mark must have acquired distinctiveness**





through use or percentage of the EU population for which such acquisition must be proven. To prove acquired distinctiveness through use, it is incorrect to argue that it is sufficient to adduce evidence of such acquisition for certain Member States whose population represents a significant proportion of the population of the European Union as a whole, where there is no evidence of use for one or more other Member States (paras 29-30). Insofar as the GC considered that the mark was devoid of any distinctive character throughout the EU, which, at the date of submission of the application for registration of that mark, consisted of 27 Member States, registration of this mark required proof of the acquisition of distinctiveness through use in all these Member States and not only in some of them, even where the combined population of the latter represented a significant proportion of the population of the EU (para. 32). Since acquisition of distinctiveness through use was not proved for 15 EU Member States, the main plea must be rejected (paras 36-40). Furthermore, the GC was not required to state in the judgment under appeal whether the population of the four Member States for which acquired distinctiveness through use was proved represented a significant proportion of the total population of the EU, since that question was devoid of relevance for the registration of the mark (para. 38).

♦[T-801/17](#); **ORIGINAL excellent dermatest 3-star-guarantee.de (fig.)**; *Dermatest Gesellschaft für allergologische Forschung u. Vertrieb von Körperpflegemitteln mbH v EUIPO*; Judgment of 14 December 2018; EU:T:2018:970; Language of the case: DE



The applicant sought to register the figurative mark above as an EUTM for *services of a medical and bacteriological laboratory; medical research; production of expertise in the field of allergology (scientific services); all the aforementioned services exclusively for companies in the cosmetics sector, in particular for companies developing and/or manufacturing and/or distributing cosmetics* in Class 42. The Office refused to register the EUTM application pursuant to Article 7(1)(b) and (c) EUTMR. The applicant appealed. The Board of Appeal (BoA) dismissed the appeal finding that the mark was descriptive and non-distinctive and that the evidence provided by the applicant did not prove the acquisition of distinctive character through the use of the mark applied for. The applicant filed an action before the General Court (GC), relying on three pleas in law: (i) infringement of Article 7(1)(b) EUTMR, (ii) infringement of Article 7(1)(c) EUTMR and (iii) infringement of Article 7(3) EUTMR. **Acquired distinctiveness.** A survey conducted in Belgium, Germany, the Netherlands and Austria is not sufficient to demonstrate that the mark applied for has acquired distinctive character in the whole EU. The survey submitted by the applicant does not cover the rest of the territory of the European Union, including, at the very least, Ireland and the United Kingdom, for which the mark applied for was found to be descriptive (para. 75). The action must be dismissed in its entirety (para. 77).



**♦T-802/17; ORIGINAL excellent dermatest 5-star-guarantee.de CLINICALLY TESTED (fig.);** *Dermatest Gesellschaft für allergologische Forschung u. Vertrieb von Körperpflegemitteln mbH v EUIPO*; Judgment of 14 December 2018; EU:T:2018:971; Language of the case: DE



The applicant sought to register the figurative mark above as an EUTM for *services of a medical and bacteriological laboratory; medical research; production of expertise in the field of allergology (scientific services); all the aforementioned services exclusively for companies in the cosmetics sector, in particular for companies developing and/or manufacturing and/or distributing cosmetics* in Class 42. The Office refused to register the EUTM application pursuant to Article 7(1)(b) and (c) EUTMR. The applicant appealed. The Board of Appeal (BoA) dismissed the appeal finding that the mark was descriptive and non-distinctive and that the evidence provided by the applicant did not prove the acquisition of distinctive character through the use of the mark applied for. The applicant filed an action before the General Court (GC), relying on three pleas in law: (i) infringement of Article 7(1)(b) EUTMR, (ii) infringement of Article 7(1)(c) EUTMR and (iii) infringement of Article 7(3) EUTMR. **Acquired distinctiveness.** A survey conducted in Belgium, Germany, the Netherlands and Austria is not sufficient to demonstrate that the mark applied for has acquired distinctive character in the whole EU. The survey submitted by the applicant does not cover the rest of the territory of the European Union, including, at the very least, Ireland and the United Kingdom, for which the mark applied for was found to be descriptive (para. 75). The action must be dismissed in its entirety (para. 77).

**♦T-803/17; ORIGINAL excellent dermatest (fig.);** *Dermatest Gesellschaft für allergologische Forschung u. Vertrieb von Körperpflegemitteln mbH v EUIPO*; Judgment of 14 December 2018; EU:T:2018:973; Language of the case: DE

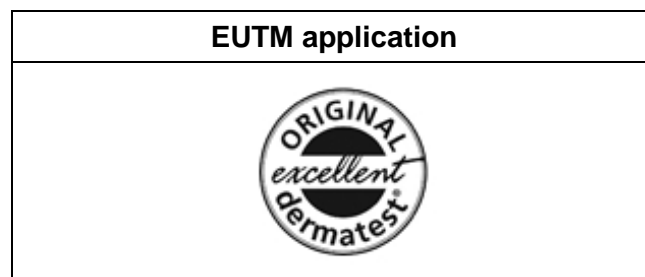

The applicant sought to register the figurative mark above as an EUTM for *services of a medical and bacteriological laboratory; medical research; production of expertise in the field of allergology (scientific services); all the aforementioned services exclusively for companies in the cosmetics sector, in particular for companies developing and/or manufacturing and/or distributing cosmetics* in Class 42. The Office refused to register the EUTM application pursuant to Article 7(1)(b) and (c) EUTMR. The applicant appealed. The Board of Appeal (BoA) dismissed the appeal finding that the mark was descriptive and non-



distinctive and that the evidence provided by the applicant did not prove the acquisition of distinctive character through the use of the mark applied for. The applicant filed an action before the General Court (GC), relying on three pleas in law: (i) infringement of Article 7(1)(b) EUTMR, (ii) infringement of Article 7(1)(c) EUTMR and (iii) infringement of Article 7(3) EUTMR. **Acquired distinctiveness.** A survey conducted in Belgium, Germany, the Netherlands and Austria is not sufficient to demonstrate that the mark applied for has acquired distinctive character in the whole EU. The survey submitted by the applicant does not cover the rest of the territory of the European Union, including, at the very least, Ireland and the United Kingdom, for which the mark applied for was found to be descriptive (para. 76). The action must be dismissed in its entirety (para. 78).

---

### III. RELATIVE GROUNDS FOR REFUSAL/INVALIDITY

#### A. Article 8(1)(a), 60(1)(a) EUTMR — Double identity

[No entry]



**B. Article 8(1)(b), 60(1)(a) EUTMR — likelihood of confusion**

**1. Outcome: Likelihood of confusion (LOC)**

♦ [T-398/16](#); **COFFEE ROCKS / STARBUCKS COFFEE (fig.) et al.**; *Starbucks Corp v EUIPO*; Judgment of 16 January 2018; EU:T:2018:4; Language of the case: EN

EUTM application	Earlier trade marks
	

Registration as an EUTM was sought for the figurative mark above for services in Class 43. An opposition was filed based, inter alia, on earlier EU trade marks consisting of the figurative signs shown above, registered, inter alia, for services in Class 43, pursuant to Article 8(1)(b) and Article 8(5) EUTMR. The Opposition Division (OD) dismissed the opposition in its entirety and the opponent filed an appeal. The Board of Appeal (BoA) confirmed the OD decision and dismissed the opponent’s appeal. The opponent filed an action before the General Court (GC) relying on two pleas in law: (i) infringement of Article 8(1)(b) EUTMR and (ii) infringement of Article 8(5) EUTMR. **(i) ARTICLE 8(1)(b) EUTMR. Relevant public.** The relevant public is the general public of the European Union, including the United Kingdom and Spain (para. 18), which was not disputed by the parties. **Comparison of services.** The contested mark’s services were identical to the earlier marks’ services: *café, cafeteria, snack bar, coffee bar and coffee house* (para. 22), which was not disputed by the parties before the court. **Comparison of signs.** As a whole, the signs are visually similar in three aspects: (a) circular devices consisting of a figurative element placed in the centre and a surrounding broad band with verbal elements of identical structure and two smaller white figurative elements (para. 51), (b) use of the same colours (black and white) and use of the same font for the word elements ‘starbucks coffee’ and ‘coffee rocks’ (para. 52), (c) the common word ‘coffee’, which, despite its descriptive



character, is an important similarity factor, especially when some of the earlier marks have a reputation (para. 55). The signs are phonetically similar due to the common word ‘coffee’ and the similar endings of the words ‘rocks’ and ‘starbucks’: the ending ‘rocks’ may be regarded as phonetically similar to the ending ‘bucks’ on account of the relevant English-speaking public’s pronunciation of the letters ‘o’ and ‘u’ (para. 62). From a conceptual standpoint, on account of the general appearance of the marks and the presence of the word ‘coffee’ in both marks, the relevant public will associate the earlier marks and the contested mark with the concept of a ‘coffee house’ (para. 64). **Likelihood of confusion.** Following an overall assessment of the likelihood of confusion, namely the identity of the services, the reputation of the earlier marks, as well as the proven similarity of the signs and taking into account the rules of interdependence, there is a likelihood of confusion (paras 67-69). The BoA erred in ruling out any similarity, even a low degree of similarity, between the marks (para. 71). **Assessment of loc in opposition proceedings.** The likelihood of confusion should have been assessed globally, since the protection in favour of marks with a reputation may apply even if there is a lower degree of similarity between the signs. The BoA should not have refused to assess LOC globally on the sole grounds that the marks were dissimilar (para. 82).

♦ [T-204/16](#); **METABOX / META4 et al.**; *Sun Media Ltd v EUIPO*; Judgment of 16 January 2018; EU:T:2018:5; Language of the case: EN

EUTM application	Earlier trade marks
METABOX	 <b>META4</b>



The applicant sought to register the word mark METABOX for the services in Classes 35, 38, 41 and 42. An opposition based on the earlier EU word marks (i) **META4**, (ii) **META4**, (iii) **META4** and (iv) the unregistered Spanish word mark **META4**, registered for the services in (i) Classes 35 and 38; (ii) Class 42; (iii) Class 35, and (iv) for the services corresponding to the following description: *advertising; business management; business administration; office functions; information and advice on human resources and personnel; assistance to businesses relating to human resources organisation and management; payroll preparation and providing external human resource department services; salary data processing, salary calculation, human resource management data processing; retailing in shops and via global computer networks of computer goods and software, as well as on*



the earlier EU figurative mark (v)  and (vi) the Spanish figurative mark registered for the services in (v) Class 42 and (vi) Class 41 was filed pursuant to Article 8(1)(b) EUTMR. The Opposition Division (OD) upheld the opposition in part for the services in Class 41 (*entertainment; cultural and sporting activities; organisation of exhibitions for cultural or educational purposes*) and for all the services in Classes 35, 38 and 42. The opponent appealed against the OD’s decision and the Board of Appeal (BoA) dismissed the appeal. It found that the marks had an average degree of visual similarity and some phonetic and conceptual similarity, and that there was a likelihood of confusion for part of the contested services due to a similarity of the signs and an identity or similarity between the services. The applicant raised three pleas in law: (i) infringement of Article 8(1)(b), (ii) infringement of Article 94 EUTMR and (iii) infringement of the general principles of EU law. **On the first plea in law.** The relevant public comes from the European Union for the earlier EU word mark and Spain for the two earlier Spanish word



marks, while the services concerned were directed at the public at large and professional consumers whose level of attention varied from average to high (para. 30). **Comparison of the services.** They are partly identical and partly similar (para. 32). **Comparison of the signs.** There is similarity between the signs globally. Both of the signs have the element ‘meta’ at the beginning but each one has a particular element, namely ‘4’ and ‘box’ (para. 38). **Dominant and distinctive character.** In Spanish, ‘meta’ is the word for ‘goal’ or ‘aim’ (para. 39) and it will tend to be perceived as such by the relevant Spanish-speaking public in the earlier marks (para. 40). None of the possible meanings of the common element ‘meta’ of the signs at issue is directly or indirectly descriptive of the services concerned and therefore it possessed a normal distinctive character (para. 41). The element ‘4’ has a normal distinctive character (para. 42). The element ‘box’ will be understood by the relevant public which has a sufficient knowledge of the English language, and for this part of the public it will have a lower than average distinctive character, while for the rest of the public it will have a normal distinctive character (para. 43). **Visual comparison.** Both have the element ‘meta’ placed at the beginning but the typeface and the graphic representation are not very original or eye-catching. The figurative elements used will not influence the overall impression produced, and therefore the signs have an average degree of visual similarity (paras 47-49). **Phonetic comparison.** They coincide in their first two syllables, ‘me’ and ‘ta’, which gives them a certain degree of phonetic similarity (paras 50-51). **Conceptual comparison.** The relevant Spanish-speaking public will first of all tend to pronounce the element ‘4’ in the same way as the Spanish word ‘cuatro’ (para. 54). Even if the relevant Spanish-speaking public perceives the element ‘meta’ as a prefix of Greek it is unlikely that a prefix of Greek origin will cause it to pronounce the element ‘4’ in the same way as the English word ‘four’ (para. 55). The signs at issue have a certain degree of conceptual similarity for all of the relevant public due to the presence of the element ‘meta’ at their beginning and they have at least a low degree of conceptual similarity, for that part of the relevant public which will understand the meaning of the element ‘box’ of the mark applied for (para. 64). **Likelihood of confusion (LOC).** Since the relevant territory is that of the European Union, there is a LOC for the Spanish-speaking part of the relevant public, because of the visual and phonetic similarity between the signs at issue and the identity or the similarity of the services in question (para. 75). **On the third plea in law.** The applicant merely states that the BoA infringed the general principles of EU law, without elaborating any further on its plea, so this plea must be dismissed as inadmissible (paras 77-80).

♦[T-273/16](#); **METAPORN / META4 et al.**; *Sun Media Ltd v EUIPO*; Judgment of 16 January 2018; EU:T:2018:2; Language of the case: EN

EUTM application	Earlier trade marks
<b>METAPORN</b>	<b>META4</b>  



The applicant sought to register the word mark **METAPORN** as an EUTM for services in Classes 35, 38, 41 and 42. An opposition based on, inter alia, the earlier EU word mark **META4** (Classes 35, 38 and 42), the EU figurative mark  (Classes 38 and 42) as well the Spanish word mark **META4** (Class 35) and the Spanish figurative mark  (Classes 35 and 41), was filed pursuant to Article 8(1)(b) and



(2) EUTMR. The Opposition Division (OD) partly upheld the opposition and refused to register the contested mark for all services in Classes 35, 38 and 42. The applicant filed an appeal, which was dismissed by the Board of Appeal (BoA). It found that there was a likelihood of confusion, at least on the part of the Spanish-speaking public, since the contested services in Classes 35 and 38 were identical and those in Classes 41 and 42 were similar, and given the visual, phonetic and conceptual similarity, as well as the normal degree of distinctiveness of the earlier marks. The applicant filed an action before the General Court (GC) relying on three pleas in law: (i) Article 8(1)(b) EUTMR, (ii) Article 94 EUTMR, and (iii) infringement of the general principles of EU law. **Relevant public.** The relevant public was the public at large and professional consumers with an average to high level of attention for services in Classes 35, 38 and 42, and the general public with an average level of attention for services in Class 41. The relevant territory was, firstly, the European Union and, secondly, Spain, for the earlier Spanish word and figurative mark (para. 31). **Comparison of services.** The services covered were partly identical and partly similar. The identical or similar nature of the services in Classes 35, 38 and 42 of the mark applied for was confirmed. However, contrary to the standing case-law, the court confirmed that adult entertainment services in Class 41 of the contested mark and the broadcasting and telecommunications services in Class 38 of the earlier EU marks were complementary and, therefore, they had at least a low degree of similarity (para. 43). **Comparison of signs.** The common element ‘meta’, due to its more distinctive character and its position at the beginning of the contested mark, is dominant, whereas the element ‘meta’ will tend to be perceived as meaning ‘goal’ or ‘aim’ by the relevant Spanish-speaking public in the earlier EU mark (para. 51). (i) The signs are visually similar, due to their shared dominant and distinctive element ‘meta’, that is more likely to catch the consumer’s attention than the other components (para. 57). (ii) The signs are phonetically similar, as they coincide in their first two syllables, ‘me’ and ‘ta’, which form the distinctive and dominant element ‘meta’ (para. 59). (iii) Only the contested mark, taken as a whole, will have a meaning attributed to it by the relevant public: it will be perceived as a combination of the concepts ‘meta’ and ‘porn’ (both having a meaning) and it will be understood as alluding to adult entertainment services. On the contrary, the element ‘4’ will be perceived as ‘cuatro’ and not ‘four’ on behalf of the Spanish-speaking public. Therefore, the earlier mark, taken as a whole, will not have any meaning, nor will it evoke the English term ‘metaphor’ for that part of the public (paras 68-72). Given the visual and phonetic similarities, and taking into account that the Spanish-speaking part of the public will perceive the element ‘meta’ as meaning ‘goal’ or ‘aim’ (the most distinctive and dominant element of the contested mark which is also present at the beginning of the earlier EU mark), there is some degree of conceptual similarity (paras 83-84). **LOC:** Since the relevant territory is that of the European Union, there is likelihood of confusion for the Spanish-speaking part of the relevant public, because of the visual, phonetic and conceptual similarity between the signs and the identity or the similarity of the services, which is sufficient to prevent the registration of the contested mark (para. 87). **On the infringement of general principles of EU law.** The abstract reliance on general principles of law, without identifying those principles, does not constitute a summary of the pleas in law, since there was no further elaboration on the relevant plea (paras 91-92).



♦[C-418/16 P](#); **mobile.de**; *mobile.de GmbH v EUIPO*; Judgment of 28 February 2018; EU:C:2018:128; Language of the case: DE

EUTM	Earlier trade mark
<p style="text-align: center;">mobile.de</p> 	

The EUTM proprietor was granted the registration of the EU word mark **mobile.de** and the figurative mark above as EUTMs for goods and services in Classes 9, 16, 35, 38 and 42. Two applications for invalidity were filed pursuant to Article 60(1)(a) EUTMR, relying on the earlier Bulgarian figurative mark above covering services, inter alia, in Classes 35 and 42. The Cancellation Division (CD) dismissed both applications, on the ground that proof of use of the earlier mark was not provided. The CD's decisions were appealed and the Board of Appeal (BoA) found proof of genuine use of the earlier Bulgarian mark, but only for *advertising services for motor vehicles* in Class 35 and upheld the appeal. Since the CD had not examined likelihood of confusion, the BoA referred the case to the CD for examination. The EUTM proprietor filed two actions against the BoA's decisions before the General Court (GC), which dismissed both. The EUTM proprietor filed an appeal before the Court of Justice of the European Union (CJ). **Assessment of similarity and overall impression.** When examining whether the differences between the earlier national mark and the contested marks altered the distinctive character of the earlier mark, the GC assessed both their aural similarity, noting, in particular, that they share the word 'mobile' and that the addition of certain terms, such as '.bg', 'bg' or 'n' in those signs, makes negligible differences. Furthermore, there was their conceptual similarity, highlighting the message conveyed by each of them and their perception by the public. It also examined the overall impression of the marks, taking into account the absence of figurative elements of the contested word mark **mobile.de** (paras 76 and 77). In any event, challenging the examination of the facts is outside the CJ's jurisdiction in the context of an appeal (para. 78).

[T-367/16](#); **H HOLY HAFERL HAFERL SHOE COUTURE (BILDMARKE) / HOLY et al.**; *Brunner v EUIPO*; Judgment of 25 January 2018; EU:T:2018:28; Language of the case: DE

EUTM application	Earlier trade mark
	<p style="text-align: center;">HOLY</p>



The applicant sought to register the figurative EUTM above for goods and services in Classes 3, 18, 25 and 35. An opposition based on the earlier EU word mark **HOLY**, registered for goods and services in Classes 18, 25 and 35, was filed pursuant to Article 8(1)(b) EUTMR. The Opposition Division upheld the opposition. The Board of Appeal (BoA) dismissed the applicant's appeal. It found that there was a likelihood of confusion. The applicant filed an action before the General Court (GC) relying on a single plea in law: infringement of Article 8(1)(b) EUTMR. The GC dismissed the action. **Relevant public.** All the goods and services at issue are partly aimed at the general public having an average





degree of attention. The services in Class 35 are also aimed at a specialised public having a degree of attention higher than average (para. 27). The BoA correctly focused on the German-speaking part of the relevant public (para. 31). **Comparison of goods and services.** *Perfume* is similar to a low degree to *retail services, also through websites and teleshopping, in relation to perfumery* (para. 43). *Wholesale and/or retail services in relation to clothing, shoes and textile goods and retail services in relation to clothing and footwear* are similar (para. 47). *Hosiery and clothing* are identical (para. 50). **Distinctive elements.** The word ‘Holy’ does not belong to English basic vocabulary and must be regarded as a fanciful term (para. 56). ‘Haferl’ is a German word used in Austria designating a traditional type of shoe. ‘Shoe’ and ‘Couture’ will be understood by the relevant public as an indication of a link between the EUTM application and a traditional style of shoe. Therefore, the elements ‘haferl’, ‘shoe’ and ‘couture’ have a weak distinctive character, not only with regard to shoes, but also to all other goods and services at issue that are related to traditional fashion (paras 63-70). The figurative element is not particularly distinctive either, since it will be perceived as the letter ‘H’, the first letter of the words ‘holy’ and ‘haferl’, and the figurative heart, referring to the concept of love, is a commonly used symbol in the field of folklore and traditional culture (para. 75). **Comparison of the signs.** The signs at issue are visually similar to a low degree and phonetically similar to an average degree (paras 80-85). As regards the conceptual comparison, the earlier mark does not convey any meaning and the EUTM application refers to the folk domain. The conceptual dissimilarity is not high and will be even weaker for the part of the public able to understand the meaning of ‘holy’ (paras 90-91). Therefore, the BoA did not err in finding a likelihood of confusion, even as regards the goods at issue that are purchased following a visual inspection (para. 101).

**T-113/16; DEVICE OF A PANTHER (fig.) / DEVICE OF A PANTHER (fig.) et al.;** *Arctic Cat Inc. v EUIPO*; Judgment of 30 January 2018; EU:T:2018:43; Language of the case: EN

IR designating EU	Earlier trade mark
	

The holder sought to register the international registration designating the EU for the figurative sign above for the goods in Classes 12 and 25. The intervener filed a notice of opposition for the goods in Class 25. The opposition was based on the earlier EU and UK figurative mark above, pursuant to Article 8(1)(b), (4) and (5) EUTMR. The Opposition Division (OD) upheld the opposition for the goods in Class 12 and 25. The applicant appealed against the OD’s decision and the Board of Appeal (BoA) upheld the appeal only for the goods in Class 12. Regarding Class 25, the BoA found that there was a likelihood of confusion (LOC), essentially based on the fact that (i) the relevant public is composed of the general public, whose level of attention is not above average, and of powersport professionals, whose level of attention is above average, (ii) the goods are identical, (iii) the signs are similar, given their visual similarity and their obvious conceptual similarity, and (iv) the earlier mark has an average degree of distinctiveness. The applicant raised a single plea in law: infringement of Article 8(1)(b) EUTMR. **Relevant public.** The relevant public, which is made up of consumers likely to use both the goods designated by the earlier mark and those designated by the applicant’s mark, includes, on the one hand, average consumers with an average level of attention and, on the other hand, powersport professionals, whose level of attention is higher than average. **Comparison of the signs.** The overall visual impression is dominated, in both of the signs concerned, by the black



side-on silhouette of a member of the cat family, conveying an impression of movement characterised by the position of the fore- and hind legs extending from the central part of the body and not supporting it (para. 37). Therefore, the signs are similar visually. As the concept conveyed by the signs includes the stance of these animals, the jumping position, which conveys an impression of movement, in which they are both represented, confirms that the signs are conceptually identical (para. 46). **LOC.** There is LOC between the marks at issue in the light of the average level of attention of the relevant public, the identity between the goods in question, the visual similarity of the signs concerned, their obvious conceptual similarity and the irrelevance of a phonetic comparison, the earlier mark's distinctive character being regarded as average (para. 60).

**T-457/16; Le Coq de France / le coq (fig.); Aldi Einkauf v EUIPO;** Judgment of 1 February 2018; EU:T:2018:56; Language of the case: DE

EUTM application	Earlier trade mark
Le Coq de France	

The applicant sought to register the word mark **LE COQ DE FRANCE** as an EUTM for goods in Class 29. An opposition based on the earlier German figurative mark above, registered for goods in Classes 29, 30 and 32, was filed pursuant to Article 8(1)(b) EUTMR. The Opposition Division upheld the opposition. The Board of Appeal (BoA) dismissed the applicant's appeal. It found that there was a likelihood of confusion (LOC). The applicant filed an action before the General Court (GC) relying on a single plea in law: infringement of Article 8(1)(b) EUTMR. The GC dismissed the action. **Limitation.** The restriction of the list of goods from *milk and milk products* to *cheese products* requested by the applicant after the adoption of the BoA's decision alters the subject matter of the proceedings and thus cannot be taken into account by the GC (paras 23-25). **Comparison of the goods.** *Coffee*, designated by the earlier mark, is not limited to *coffee beans* but includes *beverages with coffee* as well (para. 46). Since *milk and milk products*, on the one hand, and *coffee*, on the other hand, are complementary, in competition and have the same distribution channels, they are similar to a low degree (paras 42-44). **Dominant element.** 'Le Coq' may be considered allusive to food but the average German consumer will not perceive it directly as a description of the goods at issue or their characteristics. 'De France' will be understood as an indication of a French origin. Therefore, 'Le Coq' is the dominant element in the sign applied for (paras 60-65). 'Le Coq' is also the dominant element in the earlier mark and has an average distinctive character (para. 74). **Comparison of the signs.** Due to the distinctive character of the word element 'Le Coq', there is an average visual similarity between the signs (para. 83). They are phonetically similar to a degree that is higher than average (para. 90) and conceptually similar for the part of the German consumers understanding the meaning of 'Le Coq' (para. 98). **Likelihood of confusion.** Since the goods are identical or similar, the signs are similar and the level of attention is average or lower than average, the BoA did not err in finding LOC (para. 109).



♦[T-102/17](#); **SANTORO (fig.) / SANGRE DE TORO et al.**; *Cantina e oleificio sociale di San Marzano v EUIPO*; Judgment of 1 February 2018; EU:T:2018:50; Language of the case: EN



EUTM application	Earlier trade mark
	<p style="text-align: center;">SANGRE DE TORO</p>

The applicant sought to register the figurative sign above for *Italian wines* in Class 33. The opponent filed an opposition pursuant to Article 8(1)(b) and Article 8(5) EUTMR against all the goods in Class 33, based on, inter alia, the EU word mark **SANGRE DE TORO**, registered for *alcoholic beverages (except beers)*. The Opposition Division (OD) rejected the opposition on the ground that there was no likelihood of confusion (LOC) between the marks at issue and no link proved for Article 8(5) EUTMR. The Board of Appeal (BoA) upheld the appeal brought by the opponent and annulled the OD’s decision, holding essentially that, in the light of the identical nature of the goods and the similarity of the signs, there was a LOC on the part of the relevant public. In its application for annulment, the applicant raised three pleas in law: (i) infringement of Article 8(1)(b) EUTMR on the ground that the BoA did not correctly assess the similarity of the goods, (ii) infringement of Article 8(1)(b) EUTMR on the ground that the BoA did not correctly assess the similarity of the signs, (iii) infringement of Article 8(5) EUTMR and distortion of the evidence in relation to the assessment of the reputation of the earlier mark. **On the comparison of goods.** As the earlier mark was not subject to the requirement of proof of use, the scope of protection conferred by that mark could not be restricted solely to Spanish wines, as wrongly claimed by the applicant. The goods protected by that mark are therefore *alcoholic beverages, except beers* (para. 34). That specification is sufficiently clear and precise for the purposes of judgment ‘IP Translator’ (19/06/2012, C-307/10, IP Translator, EU:C:2012:361) (para. 39). As the earlier mark’s *alcoholic beverages, except beers* include the contested mark’s *Italian wines*, the goods are identical (para. 37). **On the comparison of signs.** The signs are visually similar to a certain degree. Notwithstanding the differences in the figurative elements and the absence of the letters ‘gre’ and ‘de’ in the contested sign, the signs coincide in the letters ‘san’ and ‘toro’ (para. 48). Phonetically, the signs are similar. The difference, resulting from the two additional syllables in the earlier mark, does not outweigh the phonetic similarity due to the elements in common, ‘san’ and ‘toro’ (para. 50). Conceptually, the comparison is essentially neutral from the perspective of the part of the European Union public that does not perceive any concepts in the signs at issue or that perceives only a reference to a tree or grapevine (para. 56). A substantial portion of the consumers in the European Union will not perceive the term ‘SANTORO’ as relating to the idea of sainthood just because of the Latin origin of the terms ‘san’ or ‘sanct’, and will not ascribe any meaning to the word ‘sangre’, not even on account of its alleged proximity to the word ‘sangría’ (paras 53 and 55). There is a LOC between the marks at issue because of the identity between the goods, the average level of attention of the relevant public, the phonetic and, to a lesser extent, visual similarity of the signs, the normal inherent distinctiveness of the earlier mark and because the goods at issue are generally consumed after being ordered orally (para. 57).

[T-775/16](#); **CRABS (fig.) / DEVICE OF A CRAYFISH (fig.)**; *Dochirnie pidpriemstvo*



*Kondyterska korporatsiia 'Roshen' v EUIPO*; Judgment of 7 February 2018; EU:T:2018:74;  
Language of the case: EN

EUTM application	Earlier trade mark
	

The holder sought to register the figurative mark above as an international registration designating the EU for goods in Class 30. An opposition based on the earlier figurative mark above, registered for goods and services in Class 30 (*sweetmeats [candy]*), was filed pursuant to Article 8(1)(b) EUTMR. The Opposition Division (OD) dismissed the opposition, as it found that the visual and phonetic differences between the signs were sufficient to offset the similarities, irrespective of the identity between the goods and the conceptual similarity of the pictures of crayfish, and that there was therefore no likelihood of confusion. Upon the opponent's appeal, the Board of Appeal (BoA) annulled the OD's decision and refused the contested international registration protection in the EU. The applicant filed an action before the General Court (GC), relying on a single plea in law: infringement of Article 8(1)(b) EUTMR. **Relevant public.** The relevant public is the public at large, with a low to average level of attention (average for luxury confectionery). The relevant territories are Benelux, Bulgaria, Germany, Greece, Spain, France, Croatia, Italy, Cyprus, Latvia, Lithuania, Poland, Portugal, Romania, Slovakia and the United Kingdom (para. 19). **Comparison of the goods.** The goods covered are identical (*confectionery and sweetmeats [candy]*) (para. 21). **Comparison of the signs.** The signs are visually similar to an average degree; the graphic representations of crayfish are the distinctive and dominant elements that have the most significant impact on the consumer's overall impression in both signs, due to their size and position. The representations of crayfish, situated in the centre of the contested sign, are significantly larger than the word element 'crabs' (para. 39). Phonetically, the signs are different for Bulgarian-speaking consumers and consumers with some knowledge of Russian but are not phonetically comparable for consumers who are unable to pronounce the word elements of the earlier sign written in Cyrillic letters, since they are incomprehensible and illegible for that part of the relevant public (para. 53). The signs are conceptually similar, since they both contain the dominant and distinctive representations of crayfish. However, their word elements are meaningless for the parts of the relevant public who do not understand Russian or Bulgarian and so will not understand the meaning of the verbal elements 'раковые шейки', or who do not understand English or French and so will not understand the word element 'crabs' (para. 55). **Distinctiveness of the earlier mark.** The evidence submitted to demonstrate the low degree of distinctiveness of the earlier mark in relation to Belarus, Russia and Ukraine does not relate to the relevant territories (paras 63). **Likelihood of confusion.** Given the identity between the goods, the low to average level of attention of the consumer, in addition to the considerable importance of the graphic representations of crayfish in the overall visual impression of both signs, and of the coinciding arrangement of the crayfish in a vertical line in the centre of the signs,



there is likelihood of confusion, since the similarities outweigh the differences to a sufficient degree (para. 70).

**T-45/17; CK1 / CK (fig.); Kwang Yang Motor Co., Ltd v EUIPO**; Judgment of 20 February 2018; EU:T:2018:85; Language of the case: EN

EUTM application	Earlier trade mark
CK1	

The applicant sought to register the word mark **CK1** as an EUTM for goods in Class 12 (*motorcycles, electric motorcycles*). An opposition based on the earlier figurative mark above registered for goods and services in Classes 12, 40 and 42 was filed pursuant to Article 8(1)(b) EUTMR. The Opposition Division (OD) upheld the opposition insofar as it found a likelihood of confusion. The applicant appealed the OD’s decision and the Board of Appeal (BoA) dismissed the appeal, since it found that, given the similarity of the goods, the visual and phonetic similarity of the signs, and notwithstanding the high level of attention of the relevant public, there was a likelihood of confusion. The applicant filed an action before the General Court (GC) relying on a single plea in law: infringement of Article 8(1)(b) EUTMR. **Relevant public.** The goods target both the general public and a professional public in the EU with a high level of attention, given their value and nature (para. 22). **Comparison of the goods.** The contested trade mark’s motorcycles and the earlier mark’s automobiles are similar at least to an average degree because of their nature and intended purpose (land vehicles intended for the carriage of passengers), and insofar as they target the same public (para. 33). They are also subject to the same road safety requirements and require knowledge of the same rules of the highway code relating to the use of public roads (para. 32). They are not complementary, since one is not indispensable or important for the use of the other (para. 31). **Comparison of the signs.** (i) The signs are visually and phonetically similar, insofar as the earlier trade mark (a pair of upper-case letters, ‘CK’) is entirely included in the contested mark (para. 45). This word element will also appear to be more distinctive than the number ‘1’, the presence of which in the contested mark does not suffice to rule out similarity (para. 46). The stylistic elements of the earlier trade mark are essentially decorative and will only have a limited impact on the relevant public’s visual perception (para. 48). (ii) The signs cannot be compared conceptually, since neither of the marks has a meaning. **LOC.** Given the normal distinctiveness of the earlier trader mark, the similarity of the goods and the visual and phonetic similarity of the signs, and despite the high level of attention of the relevant public, there is a likelihood of confusion (paras 56 and 57).



♦[C-412/16 P](#) and [C-413/16 P](#) (joined cases); **ocean beach club Ibiza (fig.) et al. / OC ocean club Ibiza (fig.) et al.**; *Ice Mountain Ibiza, S.L. v EUIPO*; Judgment of 1 March 2018; EU:C:2018:140; Language of the case: ES

EUTM applications	Earlier trade marks
	

The applicant sought to register the figurative marks above as EUTMs for, inter alia, services in Class 41. Two oppositions based on the earlier Spanish figurative marks above registered for services in Class 41 were filed respectively pursuant to Article 8(1)(b) EUTMR. The Opposition Division (OD) upheld both oppositions and the applicant appealed them. The Board of Appeal (BoA) dismissed both appeals as it found likelihood of confusion. The applicant filed two actions before the General Court (GC) relying on a single plea in law, infringement of Article 8(1)(b) EUTMR, which was dismissed, insofar as the GC found likelihood of confusion, given the identity or similarity of the services and the similarity of the signs. The applicant filed two actions before the Court of Justice of the European Union (CJ) relying on four pleas in law: (i) the incorrect assessment of the distinctiveness of the element 'OCEAN', (ii) the incorrect assessment of the dominant character of the various elements, (iii) the GC ignored relevant jurisprudence in its assessment of the similarity of the signs, and (iv) the GC erred in concluding that there was a likelihood of confusion. (i) The GC did not distort the evidence when it determined that the association with the sea was not a necessary characteristic of the services (paras 39-40). The GC did not err in not applying the judgment in case C-479/12, which interpreted Regulation No 6/2002 on Community Designs (para. 42). The GC correctly applied the jurisprudence of the burden of proof, without infringing the right of defence. The GC duly took into account the perception of the public when assessing the distinctive character of the word 'ocean' and it did not demand an excessive or too rigorous level of evidence (paras 44, 49 and 50). (ii) The GC did not apply automatically the principle that verbal elements are in general more important than figurative elements, but after examining the position and the dimensions of the word element in the mark, concluded that the word elements were at least as dominant as the figurative elements (paras 63 to 69). The CJ clarifies the content of judgment in case T-134/06, namely that although the position and the dimensions of a weak element should be taken into account when assessing the dominant character of that element, these are



not the only ones to be considered (paras 80-81). The CJ confirms that the alleged case-law concerning invalidity proceedings under Regulation No 6/2002 is not applicable to the present case because the criteria are different (para. 83); (iii) Since the arguments only question the GC's assessment of facts concerning the similarity of the signs, in the absence of claiming a distortion of facts, this plea in law is inadmissible (paras 90-97); (iv) The GC duly considered the argument on coexistence. It identified the criteria correctly and pointed out that the applicant had the possibility of submitting evidence in order to prove that peaceful coexistence was due to the lack of likelihood of confusion, and that evidence showing that the relevant public was already aware of each of the marks before the application for registration of the contested mark was particularly relevant to that effect (paras 103-105).

**T-438/16; CIPRIANI / HOTEL CIPRIANI et al.**; *Altunis-Trading, Gestão e Serviços, Lda v EUIPO*; Judgment of 1 March 2018; EU:T:2018:110; Language of the case: EN. The holder filed an application for protection of international registration No 11 27 870 for the word mark **CIPRIANI** for *beers; mineral and aerated waters and other non-alcoholic drinks; fruit beverages and fruit juices; syrups and other preparations for making beverages* in Class 32. An opposition based on the earlier word mark **HOTEL CIPRIANI** was filed pursuant to Article 8(1)(b) EUTMR designating services in Class 42 (now Class 43) *hotels, hotel reservation, restaurants, cafeterias, public eating places, bars, catering; delivery of drinks and beverages for immediate consumption*. The Opposition Division (OD) upheld the opposition regarding all the goods in Class 32. The applicant appealed the OD's decision. The Board of Appeal (BoA) dismissed the appeal as (i) genuine use of the earlier mark was proved, (ii) there was an average degree of similarity between the goods in question and the services protected by the earlier trade mark and (iii) the degree of similarity between the marks was rather high, so that there was a likelihood of confusion (LOC) concerning all of the contested goods. The applicant filed an action before the General Court (GC), relying on two pleas in law: (i) infringement of Article 18 EUTMR and Article 47(2) EUTMR and (ii) infringement of Article 8(1)(b) EUTMR. The applicant submitted as well that any action brought by the opponent against the Cipriani Group, concerning the name Cipriani, constituted an infringement of the 1967 agreement. **On whether the bar and restaurant services are ancillary to the hotel services.** The Office refutes the claim of ancillary nature, emphasising that the evidence of use shows that the bar and restaurant services have been provided separately and independently from the hotel services. They are also offered to customers from outside the Hotel Cipriani and represent a significant proportion of the hotel's revenue (para. 27). The GC found that the evidence of use shows that, even though the restaurants and bars located in the hotel had their own name, customers chose them and recognised them because of the sign HOTEL CIPRIANI (para. 30). It dismissed the alleged ancillary nature of the bar and restaurant services and found that there had been genuine use of the earlier mark for *cafeterias, bars, catering, delivery of beverages for immediate consumption* in Class 42 (paras 32-33). **On the use of different marks for the bar and restaurant services.** It is apparent from the evidence on file that the earlier mark is always indicated in bold and in capitals, whereas the other signs are barely visible (para. 39). The BoA was thus fully entitled to find that there had been genuine use of the earlier mark, including for the services of *cafeterias, bars, catering; delivery of beverages for immediate consumption* (para. 41). **On the likelihood of confusion.** The contested goods are complementary to the services of the earlier mark and there is a certain degree of similarity with the earlier mark's services relating to the serving of food and drink (paras 50 and 61). The earlier sign is of average distinctiveness and the marks at issue are word marks that are visually and phonetically highly similar, insofar as they coincide in the word element CIPRIANI (para. 63). Given the normal distinctiveness of the earlier trade mark, the average degree of similarity between the goods and services at issue, the high



degree of visual and phonetic similarity between the signs at issue and the neutral degree of conceptual similarity between those signs, there is a LOC on the part of the relevant public (para. 74). The existence of an agreement signed in 1967 between the parties does not alter the fact that there is a LOC (paras 76-83).

♦**T-230/17; RSTUDIO / ER STUDIO**; *Rstudio, Inc. v EUIPO*; Judgment of 7 March 2018; EU:T:2018:120; Language of the case: EN. The applicant sought to register the international registration No 999 644 designating the EU for the word mark **RSTUDIO** for the goods in Class 9 (*computer software for statistical computing using the R computing language; computer software for development of software applications for statistical computing using the R computing language*). An opposition based on the earlier word mark **ER/STUDIO** was filed pursuant to Article 8(1)(b) EUTMR designating goods in Class 9 (*database software and programmes; data modelling software and programmes; entity relationship modelling software for SQL databases*). The applicant requested that the opponent submit proof of genuine use of the earlier mark. The Opposition Division (OD) upheld the opposition and the applicant filed a notice of appeal against it. The Board of Appeal (BoA) dismissed the appeal as it assessed the evidence of genuine use of the mark submitted by Embarcadero Technologies and found that such use had been proved for the relevant period; it found that the relevant public consisted of professionals, that the goods at issue were similar and that the degree of visual, phonetic and conceptual similarity between the signs was considerably high. It concluded that there was a likelihood of confusion (LOC). The applicant filed an action before the General Court (GC), relying on two pleas in law: (i) infringement of Article 47(2) and (3) EUTMR and (ii) infringement of Article 8(1)(b) EUTMR. **As regards the existence of a likelihood of confusion**, the GC arrived at the following findings. **Relevant public.** The relevant public is composed of IT professionals in the European Union with a high level of attention. **Comparison of the goods.** The goods are of the same nature (*database software and programmes*, on the one hand, and *computer software for statistical computing using the R computing language and computer software for development of software applications for statistical computing using the R computing language*, on the other hand, are in Class 9 and are mainly recorded computer programs); they have the same method of use (the satisfaction of the needs of their users with regard to statistical analysis and the use of data); they have a complementary purpose (data processing and statistical analysis are the result of the extraction of data from a set grouped together in a database and software which interrogates data so as to establish statistical relationships and database software are complementary), so they are similar (paras 46, 47, 49 and 50). **Comparison of the signs.** The element ‘studio’ has no immediate meaning for the relevant public as regards the goods at issue, so it has an average degree of distinctiveness (para. 56). The signs are visually similar as they both contain the word element ‘studio’, even if they have some differences regarding the length and the presence of an oblique stroke (paras 59-63). The signs at issue are phonetically similar as they have in common the sequence of letters ‘r’, ‘s’, ‘t’, ‘u’, ‘d’, ‘i’ and ‘o’, which will be pronounced in the same way (para. 66). In the earlier mark, the oblique stroke will lead the relevant public to pronounce the elements ‘er’ and ‘studio’ separately. The element ‘er’ might be pronounced as two separate letters of the alphabet and not as a single syllable consisting of those two letters ‘e’ and ‘r’. However, when pronounced as one syllable, it will be identical to that of the letter ‘r’ (paras 67-68). In the mark applied for, the juxtaposition of the letter ‘r’ with the word ‘studio’ will lead the relevant public to separate the consonants ‘r’ and ‘s’, with the result that the mark applied for will be pronounced as the letter ‘r’ on its own, followed by the element ‘studio’(para. 69). The signs at issue are conceptually similar as ‘studio’ has the same meanings in many languages and the letter ‘r’ refers to a computing language and the element ‘er’ refers to the concept of ‘entity relationship’ (paras 75 and 76). Given the similarity of the goods and of the signs, there is LOC





(para. 84).

♦[T-103/17](#); **NORMOSANG / NORMON et al.**; *Recordati Orphan Drugs v EUIPO*; Judgment of 9 March 2018; EU:T:2018:126; Language of the case: EN. The EUTM applicant sought to register the word mark **NORMOSANG** for the goods in Class 5 (*Pharmaceutical preparations containing human hemin*). An opposition based on four earlier rights was filed pursuant to Article 8(1)(b) and Article 8(5) EUTMR. The applicant asked that the scope of the EU mark be limited to the following goods in Class 5: *Pharmaceutical preparations containing human hemin for administration by injection or perorally for the treatment of hepatic porphyria*. The intervener submitted a statement setting out its grounds for opposition and the applicant contended that it had only proved the existence of the international registration and requested that it submit proof that its earlier rights had been genuinely used. The Opposition Division (OD) upheld the opposition for all the goods concerned on the ground that there was a likelihood of confusion (LOC) with the Spanish word mark **NORMON**. The applicant appealed OD's decision, and the Board of Appeal (BoA) dismissed the applicant's appeal. The BoA held that the existence and validity of the earlier Spanish mark had been duly proved. It also found that the relevant public were health professionals and patients with a high level of attention; that the goods were identical; that the marks at issue were visually and phonetically similar; and that there was LOC. The EUTM applicant filed an action before the General Court (GC) relying on two pleas in law: (i) infringement of Article 7(2)(a)(ii) EUTMDR and Article 8(1) and (7) EUTMDR and (ii) infringement of Article 8(1)(b) EUTMR. **Substantiation of the earlier mark.** The information necessary to prove the existence, validity and scope of protection of the earlier mark is contained in the renewal certificate provided by the intervener. The BoA was therefore able to rely on that certificate in order to find that the intervener had satisfied the requirements in Article 7(2)(a)(ii) EUTMDR. Accordingly, Article 8(1) and (7) EUTMDR is not applicable (paras 41-43). **Relevant public.** The relevant public is composed of both health professionals and patients with a high level of attention (paras 48-49). **Visual and phonetic comparison.** The marks at issue share the first five letters, 'n', 'o', 'r', 'm' and 'o', and the letter 'n' at the end of the earlier mark and as the penultimate letter of the mark applied for. Even if they differ with the group of letters 'sang', consumers normally attach more importance to the beginning of words. So the signs are visually similar as they have the same root 'normo' (para. 57). The earlier sign is composed of the two syllables 'nor' and 'mon', whereas the sign applied for is composed of three syllables 'nor', 'mo' and 'sang'. The pronunciation of the signs coincides in regard to the group of letters 'normo' and the letter 'n' and in regard to the first syllables 'nor'. So the signs are phonetically similar to an average degree (para. 58). **Conceptual comparison.** The BoA was right when it found that the word 'normosang' has no meaning, so there is no conceptual comparison possible (paras 71-72). **Incorrect assessment of the loc and unfounded reference to a family of marks.** The identity between the goods and similarity of the marks leads to LOC even for professionals. The reference to the family of marks is made in the context of the relevant public believing that the contested goods come from the same undertaking (paras 80-81). **Lack of reasoning regarding coexistence.** While the reference to the EU is unfortunate, the fact remains that the applicant did not prove coexistence without LOC (paras 93-98).



**T-346/17; Guidego what to do next (fig.) / GUIDOGO; Hotelbeds Spain SL v EUIPO;** Judgment of 13 March 2018; EU:T:2018:134; Language of the case: EN



EUTM application	Earlier trade mark
	<p style="text-align: center;">GUIDIGO</p>

The EUTM applicant sought to register the figurative sign above for the services in Classes 39, 41 and 43. An opposition based on the earlier word mark **GUIDIGO** for services in Classes 39 and 41 was filed pursuant to Article 8(1)(b) EUTMR. The Opposition Division (OD) upheld the opposition in its entirety, on the ground that there was a likelihood of confusion (LOC). The applicant filed a notice of appeal against the OD’s decision. The Board of Appeal (BoA) dismissed the appeal and confirmed that there was a LOC; it confirmed OD’s findings that the services were identical or similar; regarding the comparison of the signs, it found that the word element ‘guidego’ was the most distinctive element in the trade mark applied for; that the signs at issue were visually similar to an average degree; that, for at least the French-, Finnish- and Spanish-speaking part of the relevant public, the signs were phonetically highly similar; and that the conceptual comparison was neutral. The EUTM applicant filed an action before the General Court (GC) relying on a single plea in law: infringement of Article 8(1)(b) EUTMR. **Relevant public.** The relevant public was the general public in the European Union with an average level of attention (para. 23). **Comparison of the services.** The services were partly identical and partly similar (para. 24). **Comparison of the signs. Dominant and distinctive elements.** The mark applied for consists of the word ‘guidego’, which is the most distinctive element and is written in green and dark blue, the word sequence ‘what to do next’, written below in a smaller dark blue typeface, and a figurative element placed to the left consisting of a dark blue circle with a horizontally positioned green water drop shape at its center (para. 27). The element ‘guidego’, because of its size and its position, is the dominant element of that sign (para. 28). Furthermore, this element is a juxtaposition of two words and the use of different colours makes it possible to perceive them, as well as the space between the two words (para. 32). **Visual comparison.** The signs are similar to the extent that they coincide in six out of seven letters and differ only in the central vowel. Similarly, the degree of stylisation of the word element and the additional elements of the mark applied for do not counteract the similarities between the signs. Consequently, they are similar to an average degree (para. 37). The degree of similarity exists regardless of whether the element ‘guidego’ is perceived as two separate words or as a single element (para. 38). **Phonetic comparison.** The elements ‘guidigo’ and ‘guidego’ are not existing words and will be pronounced almost identically by the French-, Finnish- and Spanish-speaking public, so they have a high degree of phonetic similarity for at least that part of the relevant public (para. 39). Regarding the words ‘what to do next’, because of the small typeface and the tendency of consumers to shorten long signs, they will probably not be pronounced (para. 42). Even if all members of the general public of the European Union recognise the element ‘guidego’ as the juxtaposition of two English words, it cannot be argued that the whole of that public will pronounce that element according to the rules of English pronunciation (para. 45). The space between the two words does not affect their pronunciation (para. 47). **Conceptual comparison.** It is neutral since neither ‘guidego’ nor ‘guidigo’ has any meaning for the relevant public. The BoA noted that the element ‘guidego’ consisted of the English words ‘guide’ and ‘go’, but found that, considered as a whole, it

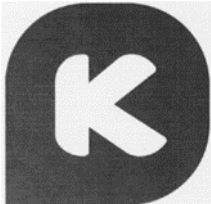

was devoid of any meaning for the non-English-speaking part of the relevant public (paras 48, 50 and 51). **Likelihood of confusion.** There is a LOC pursuant to Article 8(1)(b) EUTMR because the obvious similarity of the signs as regards the elements ‘guidigo’ and ‘guidego’ is sufficient to induce the average consumer to believe that the respective services have the same or related commercial origin (para. 61). Moreover, the services covered by the marks at issue are partly identical and partly similar. The signs at issue have an average degree of visual similarity, a high degree of phonetic similarity for at least part of the relevant public and conceptual differences only for the English-speaking part of the relevant public or for consumers who have a basic knowledge of English (para. 62).

[T-824/16](#); **K (fig.) / K (fig.) et al.**; *Kiosked Oy Ab v EUIPO*; Judgment of 13 March 2018; EU:T:2018:133; Language of the case: EN

IR designating the EU	Earlier trade mark
	

The applicant before the court obtained an international registration (IR) designating the European Union for the figurative mark above for goods and services in Classes 9, 35 and 42. An opposition based, inter alia, on the Benelux figurative trade mark above, registered, inter alia, for goods and services in the same classes, was filed pursuant to Article 8(1)(b) EUTMR. The Opposition Division (OD) partly upheld the opposition for the services *advertising; business management, business administration; office functions* in Class 35 and *design and development of computer software* in Class 42. The proprietor of the IR appealed and the Board of Appeal (BoA) dismissed the appeal as regards the above two services. The proprietor of the IR filed an action before the General Court (GC), relying on a single plea in law: infringement of Article 8(1)(b) EUTMR. **Relevant public.** The relevant public is made up of professionals, with a high degree of attention (para. 43). **Comparison of the services.** The marks’ services are identical (para. 49). **Comparison of the signs.** Despite the common element, ‘K’, the signs are visually dissimilar. In the contested IR, the vertical line and the two diagonal lines that open towards the right are closely linked, whereas in the earlier Benelux trade mark, the vertical line constituting the left-hand part of the upper-case letter ‘K’ is slightly set apart from the diagonal lines on the right-hand side of that letter. The ends of the upper-case letter ‘K’ in the contested IR are partially rounded, whereas those in the earlier Benelux trade mark are totally rounded. The shape of the black background in the two marks also differs (para. 59). Contrary to the findings of the BoA, the signs are phonetically identical; since the relevant public may recognise a letter ‘K’ in both trade marks, they are likely to be pronounced in the same way (para. 64). The signs are conceptually identical, since the element ‘K’ is present in both marks (paras 66-68). **Distinctiveness of the earlier mark.** The rounded ends of the white lines in the upper-case letter ‘K’ are not banal or ordinary elements. In addition, the white vertical line and the element resembling a chevron are separate. Moreover, that letter is an unusual graphic representation. Lastly, the impression created by the earlier Benelux trade mark is dynamic and playful. Therefore, it has an average degree of inherent distinctiveness (para. 82). **Likelihood of confusion.** Even the public with a high degree of attention will rarely have the chance to make a direct comparison between different marks, and must trust in their imperfect recollection of them. Given the identity of the services, the phonetic and



conceptual identity and despite the visual differences between the figurative elements, the relevant public will perceive the IR as an updated and modernised version of the earlier mark, rather than as a separate trade mark with a different commercial origin (para. 74). Based on the foregoing, the GC dismissed the application.

**T-806/16; CLOS DE LA TORRE / TORRES et al.; Agricola J.M., SL v EUIPO**; Judgment of 22 March 2018; EU:T:2018:163; Language of the case: ES. The EUTM applicant sought to register the word mark **CLOS DE LA TORRE** for goods in Class 29 *edible oils and fats; jellies, jams, compotes, fruit and vegetable spreads* and Class 33 *alcoholic beverages except beers*. An opposition based on the earlier trade marks **TORRES** and **LA TORRE** was filed pursuant to Article 8(1)(b) for the goods in Class 33. The Opposition Division (OD) upheld the opposition and the applicant lodged an appeal, which was dismissed by the Board of Appeal (BoA) as it found that there was a likelihood of confusion (LOC) pursuant to Article 8(1)(b) EUTMR. It limited the examination of the opposition to the earlier word mark **TORRES** and found that the relevant public was composed of Belgian, French and Luxembourgish adults who consume alcohol; that the goods in question were identical and that the signs were visually and phonetically similar; that, for the French-speaking public, the ‘clos’ element had a distinctive character lower than the average as it means ‘vineyard’ in French; that the signs at issue had more similarities than differences as they shared the most distinctive part of the sign, namely the element ‘torre’. The EUTM applicant filed an action before the General Court (GC) claiming an infringement of Article 8(1)(b) EUTMR. **Relevant public and territory.** The relevant public is the general public composed of moderately attentive and informed consumers (para. 20). For the purposes of this case, only the French-speaking consumers of the Belgium, the France and Luxembourg were taken into account (para. 24). **Comparison of the goods.** The goods are identical (para. 26). **Comparison of the signs.** The two signs are visually similar as they share the element ‘torre’ (para. 32). The pronunciation of the signs coincides in the element ‘torre’ so the overall impression of the signs is similar to each other (para. 38). The BoA was right in finding that the final ‘s’ in ‘TORRES’ will not be pronounced, since according to the rules of the French language, the final ‘s’ indicating ‘plural’ is never pronounced (para. 39). So the signs at issue are phonetically and visually similar, but they are conceptually dissimilar (para. 43). **LOC.** The element ‘clos’ means ‘vineyard’ in French and has a lower distinctive character than the element ‘torre’ (para. 48), which has no meaning for the French public (para. 49). The differences between the signs, being mainly conceptual, are not sufficient to neutralise the visual and phonetic similarities (para. 55). The BoA was right in concluding that it is likely that the public would consider that the signs’ goods come from the same company (para. 56).

**T-15/17; YAMAS (fig.) / LLAMAS; Dimitrios Mitrakos v EUIPO**; Judgment of 20 April 2018; EU:T:2018:198; Language of the case: EN

EUTM application	Earlier trade mark
<b>YAMAS</b>	<b>LLAMA</b>

The applicant sought to register the figurative mark above as an EUTM for goods in Classes 32 and 33. An opposition based on the earlier word mark **LLAMA**, registered for goods in Class 33, was filed pursuant to Article 8(1)(b) EUTMR. The Opposition Division (OD) upheld the opposition and the applicant appealed. The Board of Appeal (BoA) dismissed it, insofar as it found likelihood of confusion, given the identity between the goods concerned, the existing low visual similarities, the very high aural similarities for the





Spanish-speaking public of the EU and that the relevant public's degree of attention is no more than average. The applicant filed an action before the General Court (GC) relying on a single plea in law: infringement of Article 8(1)(b) EUTMR. **Relevant public.** The relevant public is composed of the general public and of professionals in the EU, with a focus on the Spanish-speaking part, and with an average degree of attention (paras 24 and 27). **Comparison of the goods.** The goods concerned are identical (para. 31). **Comparison of the signs.** The signs have a low degree of visual similarity, as they have the same length (five letters) and they both contain the sequence of letters 'ama'. They differ visually in their first letters, namely, 'll' in the earlier sign and 'y' in the contested sign (paras 37 and 40). The signs have a very high degree of phonetic similarity for the Spanish-speaking public of the EU: the greater part of that public will pronounce the sequence of letters 'll' of the sign LLAMA in the same way as the sound 'y' of the sign YAMAS ('ya-ma' and 'ya-mas', respectively) in most regions of Spain (para. 44). The additional letters at the end of the second syllable of the contested mark will not have a significant impact on the overall phonetic impression. The pronunciation of the letters 'll' in Latin American countries is not relevant (para. 45). Conceptually, the signs are different: it is unlikely that the average Spanish consumer of alcoholic drinks will know the Greek term 'yamas' (corresponding to the expression 'cheers') as claimed by the applicant. Evidence should have been provided to prove the contrary, since it cannot be regarded as a well-known fact (para. 49). In any event, whether or not the Greek term 'yamas' is known by the relevant public, there would still be conceptual dissimilarity (para. 50). **Likelihood of confusion.** The phonetic similarity is particularly important in this context as the drinks covered are ordered orally after their names have been seen on the menu or the wine list (paras 61-62). Furthermore, the relevant public will attribute a meaning to the word 'llama' when they see the bottle, not when they hear that name in a noisy bar or discotheque. The conceptual difference between the marks could therefore escape the notice of the greater part of the relevant public, and therefore, cannot counteract the visual and phonetic similarities (para. 63). Therefore, given the above, as well as the identity between the goods and the average level of attention of the relevant public, there is likelihood of confusion.

**T-439/16; holyGhost / HOLY; holyGhost GmbH v EUIPO;** Judgment of 20 April 2018; EU:T:2018:197; Language of the case: DE. The EUTM applicant sought to register the word mark **holyGhost** for the goods in Classes 18 and 25. An opposition based on the earlier trade mark **HOLY** was filed pursuant to Article 8(1)(b) EUTMR for all the abovementioned goods. The Opposition Division (OD) upheld the opposition in its entirety and the applicant appealed against the OD's decision. The Board of Appeal (BoA) dismissed the appeal as it found that there was a likelihood of confusion (LOC) pursuant to Article 8(1)(b) EUTMR. The EUTM applicant filed an action before the General Court (GC) relying on one plea in law: (i) infringement of Article 8(1)(b) EUTMR. **Relevant public and territory.** The relevant public is both the EU general public and a specialised public with an above-average level of attention for the latter (paras 27-28). **Comparison of the signs.** (i) Visual comparison: the beginning of the mark applied for fully contains the earlier mark (HOLY) (para. 33). The letter 'g', written in upper case, has no significant impact on the visual perception of the two words forming the mark (para. 38). The element 'Ghost' cannot be seen as dominant (para. 41). A significant part of the relevant English-speaking public would understand the term 'holy ghost' as a reference to the Holy Ghost (para. 47). Therefore, the BoA was right in finding that the two words had the same degree of distinctiveness and that the earlier mark had also a normal degree of distinctiveness (para. 49). The signs at issue are of average visual similarity (para. 52). (ii) Phonetic comparison: the presence of the word 'ghost' in the second part of the mark applied for is not sufficient to decisively differentiate the overall impression of the marks in question since the first syllables of the two marks are the same (para. 56). The BoA was right in finding



that the signs are phonetically similar to an average degree (para. 58). (iii) Conceptual similarity: the word ‘holy’ has the same meaning as the word composing the earlier mark, namely ‘sacred’ (para. 62). The concepts which will be perceived in the marks are very close to each other, being related to religious, immaterial and particularly positive connotations (para. 64). The conceptual similarity is important (para. 66). **Likelihood of confusion.** The goods in question are partly identical and partly similar. The earlier mark has an average distinctive character and the marks at issue have an average degree of visual and phonetic similarity and, conceptually, significant similarity for part of the relevant public (para. 67). Therefore, the BoA did not err in concluding that there was LOC (para. 72).

**T-426/16; Aa AROMAS artesanales (MARCA FIGURATIVA) / Aromas PERFUMARIA Beleza em todos os sentidos (MARCA FIGURATIVA) et al.; Perfumes y Aromas Artesanales, S.L. v EUIPO;** Judgment of 25 April 2018; EU:T:2018:223; Language of the case: ES

EUTM application	Earlier trade mark
	

The applicant sought to register the figurative mark above as an EUTM for goods and services in Classes 3, 35 and 39. An opposition based on the earlier figurative mark above, registered for goods and services in Classes 35 and 39, inter alia, was filed pursuant to Article 8(1)(b) EUTMR. The Opposition Division (OD) upheld the opposition. The applicant appealed against the OD’s decision and the Boards of Appeal (BoA) dismissed the appeal, insofar as it found likelihood of confusion, given the similarity or identity of the goods and the similarity of the signs, particularly due to the common dominant element ‘aromas’. The applicant filed an action before the General Court (GC) relying on a single plea in law: infringement of Article 8(1)(b) EUTMR. **Relevant public.** The relevant territory is the entire territory of the EU and the relevant public is the Bulgarian-speaking public (general consumers and professionals), with an average to high level of attention (paras 53-54). **Comparison of services.** The storage and distribution of goods of the earlier mark is a generic category of services that includes *storage and distribution of perfumery, cosmetics, air fresheners and craft soaps* of the contested mark (para. 29). The retailing services of the contested mark do not differ, in their nature and purpose, from the retailing in shops and via computer networks of *bleaching preparations and other substances for laundry use, cleaning, polishing, scouring and abrasive preparations, soaps, perfumery, essential oils, cosmetics, hair lotions and dentifrice* of the earlier mark (para. 31). Furthermore, wholesale



and retailing services of cosmetics can be provided in the same sale points and the consumers may partly coincide (para. 37). Moreover, there is complementarity between the wholesaling services of the contested mark and the services of storage and distribution of the previous mark, as the latter are necessary for the use of the former (para. 39). **Distinctiveness and dominant element.** Despite the different alphabet, the relevant public will associate the term ‘aroma’ with the Bulgarian term with the same meaning and practically same spelling ‘apомат’ (*aromat*), which is highly descriptive. On the contrary, the element ‘beleza em todos os sentidos’ has a normal distinctive character, since the relevant public will not understand its meaning (para. 78). The dominant character of the element ‘aroma’, due to its central position and its size, is nuanced by its weak distinctiveness, the different second element and the normal distinctiveness of the third element, which must be also considered for the assessment (para. 79). **Comparison of signs.** (i) The signs have a weak visual similarity: the presence of the common dominant element ‘aroma’ is counteracted by the word element ‘beleza em todos os sentidos’ in the earlier mark and the figurative element and the word element ‘artesanales’ in the contested mark, as well as the acronym ‘Aa’ (para. 90); (ii) the signs are phonetically similar to an average level, since they only coincide in their first three syllables (a-ro-mas), which however would be used in the beginning of the reference to the mark, due to its central position (para. 91); (iii) the signs are conceptually similar to an average degree: the public will understand the common element ‘aroma’, the perception of which would be reinforced by the word element ‘parfumeria’ in the earlier mark and the shape of a perfume bottle in the contested mark (para. 92). **Likelihood of confusion.** Given the similarity or identity of the services, the similarity of the signs and the level of attention of the relevant public, and despite the weak distinctiveness of the earlier mark, there is likelihood of confusion.

♦ [T-831/16](#); **ZOOM / ZOOM et al.**; *Kabushiki Kaisha Zoom v EUIPO*; Judgment of 24 April 2018; EU:T:2018:218; Language of the case: EN

EUTM application	Earlier trade marks
ZOOM	ZOOM 

The applicant sought to register the word mark **ZOOM** as an EUTM for goods in Class 9. An opposition based on the earlier word mark **ZOOM**, registered for goods in Classes 9 and 15, and the figurative mark above, registered for Classes 9 and 15, was filed pursuant to Article 8(1)(b), and Articles 8(4) and 8(5) EUTMR. The Opposition Division (OD) partly dismissed the opposition for certain goods that were found to be different from the earlier marks’ goods for which genuine use had been established. The opponent appealed and the Board of Appeal (BoA) dismissed the appeal, finding that proof of genuine use had not been established for some of the goods, namely, *photographic machines and apparatus; cinematographic machines and apparatus, portable communicating apparatus, power distribution and control machines apparatus (AC adapter) and electric wire and cable or batteries and cells*, but had been established for *handy recorders*, that is, handheld audio/sound recording devices, *recording devices for live performance recording, interfacing, controlling and sampling and guitar effects devices (stomps, pedals) including acoustic, bass and electric guitars*. The Board upheld the OD’s analysis regarding the existence of a likelihood of confusion for the goods found to be similar. The opponent appealed to the General Court (GC), relying on a single plea in law: infringement of



Article 8(1)(b) EUTMR, claiming that the Board made an error in assessing proof of use, and due to that error, wrongly restricted the scope of protection conferred by the marks and incorrectly assessed the similarity of the goods, as well as the likelihood of confusion.

**Article 8(1)(b): relevant public.** Inarguably, the relevant public comprises professional and amateur musicians, with an average level of attention (paras 64 and 67). **Comparison of goods.** There is a similarity with all the contested goods on the grounds of either identity or similarity resulting from the link of complementarity (para. 98). (i) The GC took into account the evidence, submitted before the OD, showing that cables were necessary for and important in the use of the opponent’s devices (paras 78 to 80). Due to their complementary nature, the court found a similarity between the contested mark’s *cord and cable management devices, namely, holders, wraps, brackets and clips for containing and organising audio, computer, connection, electrical, electronic, power, printer, stereo and video cables*, and the earlier marks’ goods (para. 82). (ii) Electronic devices are homogeneous in terms of the materials and components with which they are made. The complementary carrying cases and stands are designed to protect them or to fix and stabilise them accordingly. The BoA should also have acknowledged the existence of such a link between cases or supports when they are intended for *computers, cell phones, cameras, PDAs, electronic tablets* (para. 91). (iii) The contested mark’s *battery chargers and power banks*, when compared to AC adapters as a subcategory of *power distribution apparatus*, and *power cables*, are similar given that their nature, intended purpose and method of use, if not completely identical, are very close (para. 97). **Comparison of the signs.** The contested sign is identical to the earlier word mark and almost identical to the earlier figurative mark, since the figurative component has little effect on the similarity of those marks (para. 105). **LOC.** Given the average level of attention of the relevant public, the identity or similarity of the signs, and the similarity of the goods covered, there is LOC (para. 114).

♦[T-288/16](#); **M’Cooky / MR. COOK (fig.)**; *Convivo GmbH v EUIPO*; Judgment of 26 April 2018; EU:C:2018:231; Language of the case: EN

IR designating the EU	Earlier trade mark
M’COOKY	

The IR holder designated the EU for **M’COOKY**, covering goods and services in Classes 30 and 43. An opposition based on the earlier Spanish figurative mark above, registered for goods in Classes 29, 30 and 31, was filed pursuant to Article 46 EUTMR. The Opposition Division (OD) partly upheld the opposition. The Board of Appeal (BoA) dismissed the IR holder’s appeal. The IR holder appealed to the General Court (GC) to annul the BoA’s decision, relying on a single plea in law, namely, infringement of Article 8(1)(b) EUTMR, submitting that the marks were not visually, phonetically or conceptually similar. **Relevant public.** A significant number of Spanish consumers, particularly the older generation, do not grasp the meaning of the word ‘cook’ which, unlike the word ‘Mr’, is not a basic English word. Therefore, it is appropriate to assess likelihood of confusion (LOC) solely in relation to that part of the public (paras 40-45). **Distinctive elements.** A descriptive English word,





such as ‘cook’, which is not understood by a significant part of the Spanish public is fanciful and thus has ‘normal’ distinctiveness for that part of the public (paras 40, 56-57). **Visual similarity.** Since the word ‘cook’ is part of ‘cooky’ in the IR, and verbal elements are more distinctive than figurative elements, the signs at issue are visually similar. **Phonetic similarity.** A significant number of consumers will pronounce the marks as ‘mister kuk’ and ‘mkuki’ respectively. They are phonetically similar given their common initial ‘m’ sound and the coincidence in the sound ‘kuk’ (paras 72-73). **Conceptual similarity.** For the section of the public that does not understand the meaning of words like ‘cook’ or ‘cookie’ (of which ‘cooky’ is the phonetic equivalent), the marks in conflict are not conceptually similar (paras 76-78).

♦[T-234/17](#); **DIAMOND ICE / DIAMOND CUT**; *Siberian Vodka AG v EUIPO*; Order of 3 May 2018; EU:T:2018:259; Language of the case: DE. The international registration holder (IR holder) sought to register the international registration designating the EU, **DIAMOND ICE**, for goods in Class 33. An opposition based on the earlier EU word mark **DIAMOND CUT**, registered for goods in Class 33, was filed pursuant to Article 8(1)(b) EUTMR. The Opposition Division (OD) upheld the opposition insofar as it found likelihood of confusion. The IR holder appealed and the Board of Appeal (BoA) dismissed the appeal, since it also found likelihood of confusion, given the identity between the goods, the average phonetic and visual similarity, as well as the average inherent distinctiveness. The IR holder filed an action before the General Court (GC) relying on a single plea in law: infringement of Article 8(1)(b) EUTMR. **Relevant public.** The relevant public is the general public of the EU, with an average (medium) level of attention, since alcoholic beverages are usually widely consumed, and they are sold in shopping centres, supermarkets, cafes and restaurants (paras 22, 25). **Comparison of goods.** The goods are identical (*alcoholic beverages*) (para. 27). **Comparison of signs.** Even though the word element ‘diamond’ may convey certain laudatory allusions and therefore may have a weak distinctive character, this does not mean that it will not be taken into account in the comparison of the signs, since it is only one of the many factors to be considered for the assessment of similarity (paras 41-42). Regarding the argument that the common word ‘diamond’ refers to the diamond distillation of vodka, that would refer only to vodka and it could not be deemed to be descriptive of the production process of all alcoholic beverages. Moreover, the previous BoA decision regarding the descriptiveness of the sign **DIAMOND FILTRATED** cannot be applied for the word element ‘DIAMOND’ (para. 49). (i) The signs are visually similar to an average degree: the beginnings of the signs are identical and they differ only in the last three letters of the ten letters in total. They are identical in terms of structure and length, and they are also each composed of two words, with the longer word being at the beginning and the shorter word at the end (paras 58 and 62). (ii) The signs are phonetically similar to an average degree: they have the same first three syllables, comprised in the common word element ‘diamond’ (para. 63). (iii) It cannot be discarded that the sign ‘diamond ice’ would have no meaning for the relevant public, which could just perceive them as the mere juxtaposition of two words. Moreover, even if a part of the public would perceive it as a reference to a diamond made of ice, that would not exclude the possibility of an existing conceptual similarity with the previous mark, being perceived in both marks as a reference to the shape of a diamond (para. 66). **LOC.** Given the average level of attention of the relevant public, the identity between the goods and the average visual and phonetic similarity of the signs, as well as the inherent distinctiveness of the earlier mark, there is likelihood of confusion (para. 77). **Scope of proceedings.** The descriptiveness of a mark cannot be raised within the context of opposition proceedings, since this absolute ground of refusal cannot be examined as part of the opposition procedure, as it refers to the validity of registrations on behalf of the Office or a national office (para. 75).



♦[T-429/17](#); **LABORATOIRES MAJORELLE / MAJORELLE et al.**; *Laboratoire Majorelle v EUIPO*; Judgment of 3 May 2018; EU:T:2018:250; Language of the case: FR. The applicant sought to register the word mark **LABORATOIRES MAJORELLE** for the goods in Classes 3, 5 and 10. An opposition based on the earlier mark has been filed for the goods and services in Classes 3, 4, 5, 14, 16, 20, 21, 24, 25, 26, 28, 30, 41, 43 and 44 pursuant to Article 8(1)(b) EUTMR. The earlier mark **MAJORELLE**, which was being challenged in different opposition proceedings, was divided, and the part which covers goods in Classes 3, 5 and 10 was registered. The opposition was upheld for most of the goods, and the appeal dismissed by the Board of Appeal (BoA) as it found that there was a likelihood of confusion (LOC). The applicant appealed to the General Court (GC), relying on three pleas in law: (i) abuse in dividing the earlier right, (ii) absence of an examination of the genuine use of the divisional mark, and (iii) infringement of Article 8(1)(b) EUTMR. **On the alleged infringement of Article 8(1)(b) EUTMR**, the GC confirms that the relevant public’s level of attention was average for goods in Classes 3 and 5, as well as for *medical devices* and *dental devices* in Class 10, and was high for other goods in Class 10 (para. 59). The BoA also correctly assessed that visually and phonetically, the two signs are very similar, as they coincide in the dominant element ‘majorelle’, which constitutes the entirety of the earlier trade mark, and differs only in the element ‘laboratoires’ (para. 82). The two signs are conceptually very similar (paras 84-85). Then, the BoA correctly considered that the two conflicting signs had a high degree of similarity, due to the distinctive character of the dominant element ‘majorelle’ and the descriptive character of the element ‘laboratoires’ (para. 92). Based on the foregoing, and the nature of the goods and services in question, as well as the identity or average to low degree of similarity of those goods, the BoA correctly assessed the existence of a LOC between the trade marks at issue (para. 93).

[T-67/17](#); **tèespresso / TPRESSO et al.**; *Italytrade Srl v EUIPO*; Judgment of 18 May 2018; EU:T:2018:284; Language of the case: EN

EUTM application	Earlier trade marks
tèespresso	

The applicant sought to register the word mark **tèespresso** as an EUTM for goods in Class 30 *coffee, teas and cocoa and substitutes therefor*. An opposition based on the international registration, designating the EU, of the word mark **TPRESSO**; and on the international registration designating the EU, of the figurative mark above, both registered for goods in Classes 11 and 30, was filed pursuant to Article 8(1)(b) and Article 8(5) EUTMR. The Opposition Division (OD) upheld the opposition and the applicant appealed. The Board of Appeal (BoA) dismissed the applicant’s appeal, insofar as it found likelihood of confusion (LOC), given the average level of attention of the EU general public, the identity or similarity of the goods, and the visual and phonetic similarity of the signs. The applicant filed an action before the General Court (GC), relying on a single plea in law: infringement of Article 8(1)(b) EUTMR. **Relevant public.** The relevant territory is the EU and the relevant public consists of the general public with an average level of attention (para. 20). **Comparison of the goods.** The goods are identical or similar (para. 20). **Comparison of the signs.** There is an above average degree of visual similarity between the signs (para. 34). The contested mark and the earlier marks consist of a single word element, both beginning with the letter ‘t’, and both ending with the same group of six letters



‘presso’ (para. 30). The presence of the three additional letters ‘è’, ‘e’ and ‘s’ in the contested mark is not sufficient to rule out any similarity between the signs (para. 31). In addition, regarding the figurative mark, the stylisation of the letter ‘t’, although capable of attracting the consumer’s attention, will not prevent the identification of that letter (para. 33). There is a high degree of phonetic similarity between the signs (para. 47). The pronunciations of the initial part ‘tè’ in the contested mark and the first letter, ‘t’, in the earlier marks are highly similar for a large part of the relevant public (para. 41). The common element, ‘presso’ in each of the final parts of the signs will be pronounced in the same way (para. 42). In contrast, the group of consonants ‘tpr’ will not be pronounced naturally by consumers and cannot be regarded as forming a syllabic whole when assessing the phonetic impression produced by the signs (para. 45). There is an average degree of conceptual similarity between the signs (para. 57). Consumers are likely to recognise, in the contested mark, a word which is commonly used and easily understood by a large part of the relevant public, namely the Italian word ‘espresso’. That is a fortiori true of consumers who may identify the addition of the word ‘tea’ in the initial part, in particular, Italian consumers, for whom that word is written as ‘tè’. Furthermore, the word ‘espresso’ is commonly used throughout the EU to refer, in general, to a coffee-based beverage and, in particular, to a short, strong coffee made according to the Italian method (para. 54). **LOC.** Given the identity or similarity of the goods, the similarity of the signs and the normal distinctiveness of the earlier marks, there is LOC (paras 63, 65, 66 and 70).

**T-68/17; teaespresso / TPRESSO et al.;** Italytrade Srl v EUIPO; Judgment of 18 May 2018; EU:T:2018:283; Language of the case: EN

EUTM application	Earlier trade marks
teaespresso	<p data-bbox="997 1160 1139 1189">TPRESSO</p> 

The applicant sought to register the word mark **teaespresso** as an EUTM for goods in Class 30 *coffee, teas and cocoa and substitutes therefor*. An opposition based on the international registration, designating the EU, of the word mark **TPRESSO**; and on the international registration designating the EU, of the figurative mark above, both registered for goods in Classes 11 and 30, was filed pursuant to Article 8(1)(b) and Article 8(5) EUTMR. The Opposition Division (OD) upheld the opposition and the applicant appealed. The Board of Appeal (BoA) dismissed the applicant’s appeal, insofar as it found likelihood of confusion, given the average level of attention of the EU general public, the identity or similarity of the goods, and the visual and phonetic similarity of the signs. The applicant filed an action before the General Court (GC), relying on a single plea in law: infringement of Article 8(1)(b) EUTMR. **Relevant public.** The relevant territory is the EU and the relevant public consists of the general public with an average level of attention (para. 20). **Comparison of the goods.** The goods are identical or similar (para. 20). **Comparison of the signs.** There is at least an average degree of visual similarity between the signs (para. 34). The contested mark and the earlier marks consist of a single word element, both beginning with the letter ‘t’, and both ending with the same group of six letters ‘presso’ (para. 30). The presence of the four additional letters ‘e’, ‘a’, ‘e’ and ‘s’ in the contested mark is not sufficient to rule out any similarity between the signs (para. 31). In addition, regarding the figurative mark, the stylisation of the letter ‘t’, although capable of attracting the consumer’s attention, will not prevent the identification of that letter (para. 33). There is



a high degree of phonetic similarity between the signs and almost identity for the English-speaking public (para. 47). The pronunciations of the initial part ‘tea’ in the contested mark and the first letter, ‘t’, in the earlier marks are highly similar for a large part of the relevant public, in particular for English-speaking consumers or consumers who have a basic knowledge of English (para. 41). The common element, ‘presso’ in each of the final parts of the signs will be pronounced in the same way (para. 42). In contrast, the group of consonants ‘tpr’ will not be pronounced naturally by consumers and cannot be regarded as forming a syllabic whole when assessing the phonetic impression produced by the signs (para. 45). There is an average degree of conceptual similarity between the signs (para. 57). Consumers are likely to recognise, in the contested mark, a word which is commonly used and easily understood by a large part of the relevant public, namely the Italian word ‘espresso’. That is a fortiori true of consumers who may identify the addition of the English word ‘tea’ in the initial part of that mark. Furthermore, the word ‘espresso’ is commonly used throughout the EU to refer, in general, to a coffee-based beverage and, in particular, to a short, strong coffee made according to the Italian method (para. 54). **LOC.** Given the identity or similarity of the goods, the similarity of the signs and the normal distinctiveness of the earlier marks, there is LOC (paras 63, 65, 66 and 70).

**T-807/16; N & NF TRADING / NF ENVIRONNEMENT (fig.) et al.; MIP Metro Group Intellectual Property GmbH & Co. KG v EUIPO;** Judgment of 7 June 2018; EU:T:2018:337; Language of the case: EN

EUTM application	Earlier trade mark
N & NF TRADING	

The applicant designated the European Union for international registration No 1 086 884 covering the word mark **N & NF TRADING** for services in Classes 35 and 39. The intervener filed a notice of opposition to the international application designating the European Union for all the abovementioned services. The opposition was based on several earlier rights, in particular the EU figurative mark depicted above. The earlier mark was registered, inter alia, for services in Classes 35 and 39. The opposition was filed pursuant to Article 8(1)(b) EUTMR. The Opposition Division (OD) upheld the opposition on the basis that there was a likelihood of confusion (LOC). The applicant appealed OD’s decision, and the appeal was dismissed by the Board of Appeal (BoA). It found that the contested services were identical to the earlier mark’s services in Classes 35 and 39; that the components ‘nf’ and ‘n & nf’ were the distinctive and dominant components of the signs at issue; that the marks had visual and phonetic similarities which no conceptual difference could counteract; that there was a likelihood of confusion between the marks at issue, in particular for the French public. The EUTM applicant filed an action before the General Court (GC) relying on a single plea in law: infringement of Article 8(1)(b) EUTMR. **Relevant public.** The BoA correctly found that since the earlier mark is an EU trade mark the territory to be taken into account in order to assess LOC is the European Union. Certain services in Class 39 might interest the general public, while the remainder of the services mainly interest undertakings and companies with a high level of attention (para. 21). **Similarity of the services.** The BoA correctly found that the application’s services are identical to the services protected by the earlier mark in Classes 35 and 39 (para. 22). **Comparison of the signs.** The BoA carried out a global assessment of LOC and did not restrict its assessment solely to one part of the earlier mark (para. 29). In the earlier mark the verbal elements ‘nf environnement’ are set in white against a principally blue oval background with a leaf-like





device in green in the inner part of the upper border (para. 31). As the word ‘environnement’ is descriptive and is only slightly capable of holding the attention of the public, the BoA found that the combination of letters ‘nf’ is the distinctive and dominant component of the earlier mark (para. 32). The earlier mark’s services in Classes 35 and 39 and the component ‘environnement’ describe the protection of the environment in the context of providing the services at issue. The component refers to their ecological quality and will likely be perceived by the relevant public as an essential characteristic of the services in question. Therefore, the term ‘environnement’ will be perceived as descriptive by the relevant public (para. 36). The component ‘nf’ has no apparent meaning in connection with the services in question, located in the centre and represented with letters of a significantly larger size and thickness than those of the letters composing the term ‘environnement’. The greater length of the word ‘environnement’ does not offset its smaller size in the earlier mark; the word ‘environnement’ is unlikely to be the component which the relevant public will remember the most (para. 37). The BoA correctly found that the combination of letters ‘nf’ is the most striking component of the earlier mark and the one which a large part of the public in the European Union will remember (para. 38). The BoA correctly found that the term ‘trading’ will not be particularly distinctive for consumers who understand English and the component ‘n & nf’ will be the most distinctive and dominant component of the mark applied for (para. 39). The ampersand (&) is generally used as a typographical sign to replace the word ‘and’, the relevant public with a basic understanding of English will regard the component ‘n & nf’ as a reference to two separate entities, namely, ‘n’ and ‘nf’ (para. 40). The BoA correctly held that the relevant public will understand the distinctive and dominant component ‘n & nf’ of the mark applied for as referring to two separate entities, namely ‘n’ and ‘nf’ (para. 44). **Visual, phonetic and conceptual similarity.** The BoA found that the general impression produced by the marks at issue was that those marks were visually and phonetically similar (para. 46). Visually, the mark applied for contains the same component ‘nf’ as the earlier mark, as a distinctive component; there is a certain visual similarity between the signs which is not removed by the presence, in the earlier mark and the mark applied for, of the descriptive terms ‘environnement’ and ‘trading’ respectively or by the additional letter ‘n’ in the mark applied for (para. 47). Phonetically, the BoA correctly found that the signs were similar given that it is likely that the secondary terms in each of those signs will not be pronounced and that the component ‘nf’ will be pronounced in both marks (para. 48). Conceptually, the components ‘nf’ and ‘n & nf’ do not convey any specific concept. Furthermore, it is apparent that the components ‘trading’ and ‘environnement’ are descriptive. Consequently, there is no conceptual difference which makes it possible to offset the visual and phonetic similarity between the marks at issue (para. 49). **Distinctive character.** As regards the services in Classes 35 and 39, it is clear from the documents in the case file before the BoA that AFNOR does not provide the services in question itself. The sign ‘NF’ has thus been used in France for the sole purpose of certifying services provided by undertakings (para. 63). It cannot be found that the earlier mark has, among the French public, an enhanced ability to identify the services in Classes 35 and 39 as coming from a particular undertaking (para. 66). Consequently, the applicant is justified in submitting that the BoA incorrectly attributed an enhanced level of distinctiveness to the earlier mark for the French public (para. 70). **LOC.** The fact that the component ‘nf’ does not constitute, by itself, the earlier mark, does not prevent it from retaining an independent distinctive role in the mark applied for (para. 79). The component ‘nf’, which is common to both signs at issue, does not form a unit with the other components of the contested sign, taken as a whole, having a different meaning from the meaning of those components taken separately (para. 80). The component ‘nf’ retains, even in the absence of enhanced distinctiveness of the earlier mark in France, an independent distinctive role in the mark applied for (para. 82). Having regard to the similarity of the services, the distinctive and dominant components of the marks, the visual and phonetic similarity and the principle of



interdependence between factors, there is a likelihood that the relevant public, which includes people with a high level of attention, may believe that the services provided under the marks come from economically linked undertakings (para. 84). Although the earlier mark does not have enhanced distinctiveness in France for the services in Classes 35 and 39, the fact remains that the existence of LOC is established (para. 85). The BoA correctly found that there was LOC within the meaning of Article 8(1)(b) EUTMR.

**T-136/17; cotecnica MAXIMA (fig.) / MAXIM Alimento Superpremium (fig.); Cotécnica, SCCL v EUIPO**; Judgment of 12 June 2018; EU:T:2018:339; Language of the case: EN

EUTM application	Earlier trade mark
	

The applicant sought to register the figurative mark above as an EUTM for goods in Class 31. An opposition based on the earlier Italian figurative mark above, registered for goods and services in Class 31, was filed pursuant to Article 8(1)(b) EUTMR. The Opposition Division (OD) upheld the opposition and the applicant filed an appeal. The Board of Appeal (BoA) dismissed the appeal insofar as it found a likelihood of confusion (LOC) or, at the very least, a likelihood of association, including for the part of the relevant public with a high level of attention. It also stated that there would be a similar LOC even if the earlier mark had only weak distinctive character for the relevant public as a whole. The applicant appealed to the General Court (GC), relying on a single plea in law: infringement of Article 8(1)(b) EUTMR. **Relevant public.** The relevant public consists of the Italian general public and business consumers with an average to high level of attention respectively (para. 24). **Comparison of the goods.** The goods are identical (para. 24). **Comparison of the signs.** (i) Distinctive and dominant elements. The elements **MAXIM** and **MAXIMA** have weak intrinsic distinctive character for most of the relevant public, their distinctive character being, however, normal for a small part of that public (para. 51); the elements **MAXIM** and **MAXIMA**, insofar as concerns the mark of which each element forms part, are capable of making an impression on consumers and being remembered by them (para. 58). While the word element **cotecnica** has definite intrinsic distinctive character, since it is a fanciful term, it is nevertheless apparent from the assessments on the size and position of that element compared to the size and position of the element **MAXIMA**, that the element **cotecnica** is barely legible and likely to be ignored by the relevant public (para. 63). (ii) Visual, phonetic and conceptual comparison. The applicant contests the validity of the conclusion reached by the BoA, arguing that it is based on assessments of the distinctive and dominant character of the various word elements of the marks, the validity of which it calls into question. This criticism is not accepted (para. 70). It is noted that the finding that the signs at issue are broadly similar is in line with the case-law that two marks are similar when, from the point of view of the relevant public, they are at least partly identical as regards one or more relevant aspects (para. 71). Furthermore, it cannot be precluded that two signs are similar when they both have elements that have weak



distinctive character (para. 72) **Likelihood of confusion.** The BoA did not err in law in finding that there was a LOC between the marks at issue without concluding that such a likelihood was reduced or non-existent on account of the peaceful coexistence of other marks on the market at issue (paras 87-89).

♦ **T-165/17; EMCURE / Emcure et al.; Emcure Gesundheitsmittel aus Bad Ems GmbH v EUIPO;** Judgment of 14 June 2018; EU:T:2018:346; Language of the case: EN. The applicant sought to register the word mark **EMCURE** for services in Classes 35, 41, 42, 44 and 45. The opponent filed an opposition pursuant to Article 8(1)(b) EUTMR based on the EU word mark **EMCUR** registered for goods in Classes 5 and 10 and the German word mark **EMCUR** registered for goods in Class 5. The Opposition Division (OD) upheld the opposition in part, rejecting registration of the mark for *pharmacy advice* services in Class 44, on the basis that there was a likelihood of confusion (LOC) regarding the earlier German mark. The opponent appealed, but the Board of Appeal (BoA) dismissed the appeal. Despite the high degree of similarity of the signs, there was no LOC because none of the remaining contested services were similar to the goods of the earlier marks. The opponent appealed to the General Court (GC), relying on a single plea in law: infringement of Article 8(1)(b) EUTMR. **Comparison of the goods and services. Classes 35 and 41.** Insofar as the opponent’s goods and the contested services in Classes 35 and 41 are used by professionals, the relevant public overlaps to some extent (para. 39). However, contrary to the opponent’s position, the complementary connection between the opponent’s goods in Class 5 (*pharmaceuticals and healthcare preparations*) and the contested services in Classes 35 and 41 (*services for commercial, advertising, training and educational purposes in the area of healthcare*) was not established. Therefore, there is no similarity between those goods and services (paras 40 to 44). **Class 42.** The services in Class 42 are closely connected to pharmaceutical products (paras 49 and 50). The BoA erred in finding that the goods in Class 5 covered by the earlier German mark and the contested services in Class 42 were not similar (para. 53). **Class 44.** Medical services and pharmaceutical products target and are used by both professionals and the general public. Accordingly, those goods and services target the same consumers, have the same aim, have the same distribution channels, and are complementary (paras 56 to 60). The BoA erred in finding that the services in Class 44 and the goods covered by the earlier German mark were not similar (para. 61). **Class 45.** The opponent did not submit any argument challenging the contested decision’s legality for services in Class 45. Accordingly, the Court cannot uphold the annulment of the contested decision (paras 64 and 65). The BoA did not err in finding that there was no similarity between the services in Classes 35 and 41 and the goods in Class 5. Therefore, there was no LOC (para. 66). However, the BoA erred in finding that there was no LOC within the meaning of Article 8(1)(b) EUTMR on the part of the relevant public solely based on the incorrect finding that there was no similarity between the services in Classes 42 and 44 and the goods in Class 5 (para. 67).

♦ **T-89/17; NOVUS / NOVUS (fig.) et al.; Erwin Müller GmbH v EUIPO;** Judgment of 19 June 2018; EU:T:2018:353; Language of the case: DE

EUTM application	Earlier trade marks
NOVUS	NOVUS 

The EUTM applicant sought to register the word mark **NOVUS** for goods in Class 9. An



opposition based on the earlier trade marks above, also registered for goods in Class 9, was filed pursuant to Article 8(1)(a) and (b) EUTMR. The Opposition Division (OD) rejected the opposition on the ground that the goods and services designated by the signs in conflict were dissimilar. The applicant's appeal against the OD's decision was dismissed by the Board of Appeal (BoA). It found that a likelihood of confusion (LOC) between the signs was excluded because of the dissimilar nature of the goods and services designated by them. The EUTM applicant appealed to the General Court (GC), relying on a single plea in law: infringement of Article 8(1)(a) and (b) EUTMR. **On the special holders for mobile phones.** Considering that the functionality of the *articulated arms for telephones, articulated arms, carrier arms, foldable arms* was limited to the support of fixed telephones, the BoA committed an error of assessment that vitiates its conclusion as to the differences in nature, manufacturer and distribution channels between those goods and the *support for mobile telephones*. It must therefore be concluded that the BoA wrongly ruled out any similarity between the goods (para. 42). **On the peripherals suitable for use with computers.** Due to the very wide variety of goods that can be connected to a computer, the mere fact that 'electronic letter, parcel and package scales' can be used in connection with a computer would not suffice to characterise a similarity with *peripherals suitable for use with computers* (para. 48). The BoA correctly held that the *peripherals suitable for use with computers* were not similar to the earlier trade marks' goods (para. 49). **On the carrying cases for computers.** The BoA correctly interpreted the concept of *transport boxes* in relation to the class in which the mark for those goods was registered (para. 55). The BoA correctly held that the *tool transport cases* differed from *computer transport cases* both in their manufacturers and distribution channels and in their intended purpose (para. 56). The BoA rightly held that the *transport boxes* referred to in the earlier word mark and the *computer transport boxes* were dissimilar (para. 58). As there was similarity between some of the goods, the BoA should have assessed the LOC between the signs in conflict, taking into account all the relevant factors (para. 60).



♦[T-657/17](#); **HPC POLO / POLO**; *Gidon Anabi Blanga v EUIPO*; Judgment of 20 June 2018; EU:T:2018:358; Language of the case: EN. The applicant sought to register the word mark **HPC POLO** for goods in, inter alia, Classes 18 and 25. An opposition was filed pursuant to Article 8(1)(b) EUTMR and Article 8(5) EUTMR, based on the EU word mark **POLO** for goods in Classes 18 and 25. The Opposition Division (OD) upheld the opposition for goods in Classes 18 and 25 on the grounds of likelihood of confusion (LOC). The Board of Appeal (BoA) dismissed the applicant's appeal, finding there was LOC for all the identical or similar goods except *whips, harness and saddlery*, for which the earlier mark **POLO** was considered to have weak inherent distinctiveness. The opposition against these goods was, however, upheld on the grounds of Article 8(5) EUTMR. The applicant appealed to the General Court (GC), seeking the annulment of the decision, relying on a single plea in law, infringement of Article 8(1)(b) EUTMR. **Comparison of the signs.** The signs **HPC POLO** and **POLO** were rightly held to be visually, phonetically and conceptually similar to an average degree as the earlier mark is fully replicated in the mark applied for. The BoA obviously considered the element 'HPC' in the comparison as otherwise the result would have been that the signs were identical (para. 29). **Inherent distinctive character.** Even if the word 'polo' corresponds in some languages of the European Union to a very specific type of clothing, it retains minimum distinctive character for goods in Classes 18 and 25 that are not specifically linked to the game of polo. Furthermore, 'polo' corresponds to a sign registered as an EUTM, the validity of which cannot be challenged in opposition proceedings (paras 33 and 34). **Enhanced distinctive character.** Although the evidence of use submitted included the mark **RALPH LAUREN**, it also proved intensive use of the earlier mark **POLO**, that played an independent role while being associated with the mark **RALPH LAUREN**, being positioned above the other mark and in a larger font (para. 35).





**Global assessment.** The goods being identical and the level of attention of the public being average, the fact that the similarity of the signs may play a less important role for certain goods is amply offset by the enhanced distinctive character acquired by the earlier mark through the public's familiarity with it (para. 39).

**T-619/16; GiCapri a giacchett'e capri (fig.) / CAPRI (fig.) et al.;** *Pasquale Sicignano v EUIPO*; Judgment of 26 June 2018; EU:T:2018:385; Language of the case: IT

EUTM application	Earlier trade mark
	

The applicant sought to register the figurative mark above as an EUTM for goods and services in Classes 18, 25 and 35. An opposition based on the earlier EU figurative mark above, registered for goods in Class 25, and the earlier Italian word mark **CAPRI** (goods in Class 25) was filed pursuant to Article 8(1)(b) EUTMR. The Opposition Division (OD) dismissed the opposition as there was no likelihood of confusion between the earlier EU figurative mark and the contested mark. Further, the opponent had not proved the existence and validity of the earlier Italian word mark. The opponent appealed and the Board of Appeal (BoA) upheld the appeal, finding likelihood of confusion (LOC), given the similarity of the signs. The applicant appealed to the General Court (GC) relying on a single plea in law: infringement of Article 8(1)(b) EUTMR. **Relevant public.** The relevant territory is the EU. The relevant public is the general public with an average level of attention regarding the goods concerned. However, services in Class 35 also refer to both the general public and professionals with a higher level of attention (para. 36). **Comparison of goods and services.** The goods are partly identical and partly similar to the earlier trade mark's goods, whereas the services concerned are moderately similar (para. 36). **Comparison of signs.** (i) Visually, the marks are similar to a moderate degree: owing to its central position and clear visibility, the common and somewhat dominant element 'CAPRI' is perfectly recognisable and discernible from the element 'GI' in the contested mark; that similarity is attenuated by the difference in the arrangement, size and graphic appearance of the verbal elements (para. 61). (ii) Phonetically, the similarity between the signs is moderate, given that the trade marks coincide in the pronunciation of the syllables 'CA-PRI' and that the different purely figurative elements will not be pronounced by the public (para. 62). (iii) Conceptually, for those members of the relevant public who will recognise the presence of the word 'CAPRI' in the contested sign and know the Italian island, the trade marks will be conceptually similar to a certain extent. The remaining word and figurative elements of the contested trade mark have a conceptual content that would be identified by only a proportion of the Italian public (para. 63). **Distinctiveness of the sign.** Since the distinctive character of the word 'CAPRI' was not raised before the BoA, it was not examined and therefore cannot be raised before the GC (para. 47). Furthermore, the applicant did not provide proof that the above word would be evocative and suggestive of fashion, clothing or a specific type of clothing style (para. 52). Therefore, the earlier mark has a normal distinctive character. **Scope of proceedings.** The applicant cannot raise absolute grounds regarding geographical origin during opposition proceedings (para. 64). In any event, it has



not been demonstrated that the relevant public could believe that the goods concerned originate from Capri, since this island is not renowned for being a clothing production hub. Instead, it is famous as a tourist destination in southern Italy (para. 67). **Likelihood of confusion.** Given the identity or similarity of the goods and services, the similarities of the signs and the normal distinctive character of the earlier mark, there is LOC. The alleged coexistence in the Office’s register, and probably in the Italian Register, of several trade marks including the word ‘CAPRI’ is not a valid argument for ruling out LOC (paras 91-92).

♦[T-71/17](#); **FRANCE.COM (fig.) / France (fig.)**; *France.com, Inc. v EUIPO*; Judgment of 26 June 2018; EU:T:2018:381; Language of the case: EN

EUTM application	Earlier trade mark
	

The EUTM applicant sought to register the figurative sign above for the services in Classes 35, 39 and 41. An opposition based on the earlier trade mark above was filed pursuant to Article 8(1)(b) EUTMR. The Opposition Division (OD) rejected the opposition. The opponent appealed against the OD’s decision which was annulled by the Board of Appeal (BoA). It found that the services for which protection was sought were aimed at the general public and professionals, that the level of attention of the relevant public ranged from average to high and that the likelihood of confusion (LOC) should be assessed in the European Union. The BoA upheld the OD’s finding that the services were in part identical and in part similar. It also found that the signs had an average degree of visual similarity and were phonetically and conceptually identical, so they were highly similar overall. A LOC within the meaning of Article 8(1)(b) EUTMR could not be ruled out. The EUTM applicant appealed to the General Court (GC) relying on two pleas in law: (i) infringement of Article 8(2) and 46(1) EUTMR, infringement of Article 2(2)(b) and Article 5 EUTMDR and (ii) infringement of Article 8(1)(b) EUTMR. **The second plea in law. Comparison of the signs.** The BoA found that the stylised images of the Eiffel tower were as important as the word element ‘france’. The applicant is therefore obviously incorrect in its claim that the BoA found that the word element ‘france’ is the main element of the signs at issue (para. 49-50). The word element ‘france’ corresponds to the shortened name of the French Republic (para. 52). The BoA was correct to find that the signs at issue have three elements in common: the word element ‘france’, a stylised image of the Eiffel tower and the colours red, white and blue (para. 63). The mark applied for contains a pentagon and the abbreviation ‘.com’, elements that are not present in the earlier mark. The earlier mark contains a figurative element depicting a black Eiffel tower and a red, white and blue scarf, which do not appear in the mark applied for (para. 65). The figurative element depicting the Eiffel tower is represented differently in the signs at issue. It is large, black and a standalone element which is immediately apparent. In contrast, the same element in the mark applied for is depicted in white, inside a pentagon and is smaller (para. 66). The font of the word element ‘france’ is also different. In the mark applied for it is written in bold upper-case letters, whereas it is written in lower-case letters and in a font reminiscent of handwriting in the contested mark (para. 67). Although the signs at issue share the colours



red, white and blue, the way in which they are represented differs. The colour blue is dominant in the mark applied for, whereas the colour black, which is not present in the mark applied for, is the dominant colour in the contested mark (para. 69). It is clear that the signs at issue, considered as a whole, have only a low degree of visual similarity (para. 70). **Phonetic comparison.** The applicant is incorrect to claim that the earlier mark will be read by an English speaker as ‘Eiffel tower — france’ and by a French speaker as ‘tour Eiffel — france’. As the Eiffel tower is a world-famous French monument, consumers will likely regard it as a mere illustration of the word element ‘france’ without saying its name (para. 75). The signs at issue are almost identical. As the BoA observed, it can be assumed that many consumers will refer to the mark applied for by the word ‘france’ alone (para. 76). In those circumstances, the court found that the signs at issue are almost identical phonetically (para. 77). **Conceptual comparison.** It is clear that the signs at issue contain almost exclusively elements that refer to the same concept. The word element ‘france’ refers to the French Republic. The figurative elements in the signs at issue refer to a symbol widely known, namely the Eiffel tower and the colours red, white and blue. The same holds true for the figurative element, present only in the mark applied for, depicting a pentagon, the shape of which brings to mind the ‘Hexagon’, an expression designating the continental part of metropolitan France (para. 82). The element ‘.com’, present only in the mark applied for, is not sufficient to enable those signs to be differentiated conceptually (para. 83). Therefore, as the elements of the signs at issue convey the same concept, the presence of the word element ‘.com’ cannot have any bearing on whether those signs are conceptually identical (para. 85). Therefore, it must be concluded that the signs at issue are conceptually identical (para. 86). **LOC.** Taking into account the identity between the goods and services, the GC found LOC to exist despite the low degree of visual similarity between the signs on account of the fact that the conflicting signs are almost identical phonetically and are conceptually identical (paras 94 and 96).

**T-556/17; STAROPILSEN; STAROPLZEN / STAROPRAMEN et al.**; *Staropilsen s. r. o. v EUIPO*; Judgment of 26 June 2018; EU:T:2018:382; Language of the case: EN. The EUTM proprietor registered the word mark **STAROPILSEN; STAROPLZEN** as an EUTM for goods in Class 32 for beers, aerated waters and other non-alcoholic drinks, drinks and fruit juices, and syrups and other preparations for making beverages. An invalidity application was filed pursuant to Article 60(1)(a) EUTMR in conjunction with Article 8(1)(b) EUTMR, based on the earlier EU word mark **STAROPRAMEN** for beers in Class 32, and two earlier Czech word marks **STAROPRAMEN** for alcoholic and dealcoholic drinks of all kinds, non-alcoholic beer, beer, extraction, essence for drink production, colorific beer, and fruit juices and beers of all kinds in Class 32 respectively. The Cancellation Division (CD) upheld the invalidity application finding likelihood of confusion (LOC). The EUTM proprietor appealed, but the Board of Appeal (BoA) dismissed the appeal. The EUTM proprietor appealed to the General Court (GC) relying on a single plea in law: infringement of Article 60(1)(a) EUTMR in conjunction with Article 8(1)(b) EUTMR. **Relevant public.** The relevant public is the general public within the EU and they will display an average degree of attention since the goods are everyday consumer goods, bought at affordable prices, which are normally widely distributed, ranging from the food section of a department store to bars and cafes. (paras 24-26). **Comparison of the goods.** The goods are partly identical and partly similar to a varying degree (para. 17). **Comparison of the signs.** (i) The signs are visually similar to a high degree: firstly, due to the semicolon and the repetition of the contested mark in two languages, the relevant public will split the mark into two, focusing its attention on one of the two words. Therefore, the verbal elements of the signs share the same visual structure. Additionally, the beginning ‘STAROP’ and the ending ‘EN’ of both signs are identical (paras 38-39). (ii) Phonetically, the signs are highly similar: the pronunciation of the signs corresponds to the extent that the first two syllables are identical; the letter ‘p’



being central to the two signs and the grouping of the final letters 'EN' being identical. Furthermore, in many EU official languages the signs have the same rhythm and are pronounced with the same intonation (para. 41). (iii) Conceptually, the marks have no meaning for the substantial part of the relevant public that does not speak a Slavic language. Therefore, it is not possible to conduct a conceptual comparison of the signs (para. 45). **LOC.** Considering the identity or similarity of the goods, the above average visual and phonetic similarity, and the normal level of distinctiveness of the earlier marks, there is LOC even for the relevant public with average degree of attention (paras 47 and 51).

♦[T-739/16](#); **COSIMO / COSIFLOR**; *Akant Monika i Zbigniew Harasym sp.j. v EUIPO*; Judgment of 26 June 2018; EU:T:2018:387; Language of the case: EN. The applicant sought to register the word mark **COSIMO** as an EUTM for goods in Classes 20, 22 and 24. An opposition was filed pursuant to Article 8(1)(b) EUTMR, based on the earlier EU word mark **COSIFLOR**, registered for goods in Classes 6, 19 and 24. The Opposition Division (OD) dismissed the opposition, finding no likelihood of confusion (LOC). The opponent successfully appealed to the Board of Appeals (BoA), which found there was LOC for, at least, Dutch- and German-speaking consumers. The applicant appealed to the General Court (GC) relying on two pleas in law: (i) infringement of Article 47(2) EUTMR and (ii) infringement of Article 8(1)(b) EUTMR. **Relevant public.** The relevant public consists of EU professionals and the general public, who will have a high level of attention since the choice of the relevant goods requires a process of reflection on the part of the consumer, who will have to verify, in particular, their dimensions and will not purchase them on a daily basis (paras 38-39). **Comparison of the goods.** The goods concerned are identical or highly similar (para. 49). **Comparison of the signs.** (i) Visually, the signs are similar: they coincide in the element 'COSI' and in the vowel 'o' located, for each of the signs, in the third syllable. The fact that five of the six letters of the contested mark are included in the earlier mark counteracts the visual differences between the signs, namely the letters 'f', 'l' and 'r' of the earlier mark and the letter 'm' of the contested mark (para. 55). (ii) The signs have a certain phonetic similarity: consisting of a single word, they have the same number of syllables and the same sequence of vowels, namely 'o', 'i', 'o'. Since the letters 'f', 'l' and 'm' are located in the middle of the signs, the difference in pronunciation arising from the presence of those consonants will be minor from the point of view of members of the relevant public who hear those word elements spoken with a view to purchasing the goods concerned (paras 57-59). (iii) Since neither of the marks has any clear and specific meaning, the conceptual difference between the marks cannot be assessed in this case, at least with regard to the German- or Dutch-speaking part of the relevant public (para. 66). **LOC.** Given the normal distinctive character of the contested mark, the identity or high degree of similarity of the goods, the visual similarity and the certain degree of phonetic similarity of the signs, there is LOC (para. 68).



**T-707/16; ANTONIO RUBINI / RUTINI (fig.) et al.; Enoitalia SpA v EUIPO**; Judgment of 11 July 2018; EU:T:2018:424; Language of the case: EN

EUTM	Earlier trade mark
ANTONIO RUBINI	

The applicant sought to register the mark **ANTONIO RUBINI** for *alcoholic beverages (except beers), wines* in Class 33. An application for invalidity was filed pursuant to Article 60(1)(a) EUTMR in conjunction with Article 8(1)(b) EUTMR, based on the earlier mark above, registered for *alcoholic beverages (except beers); wine, sparkling wine, fortified wine* in Class 33. The Cancellation Division (CD) upheld the application for invalidity due to the likelihood of confusion (LOC) between the marks, as the goods in question were identical and the signs were visually, phonetically and conceptually similar. The Board of Appeal (BoA) dismissed the applicant’s appeal. It found there was a significant risk that average consumers of the goods could believe that the marks had the same commercial origin because the dominant element of the contested mark, ‘RUBINI’, is almost identical to the single word element of the earlier mark ‘RUTINI’. The applicant appealed to the General Court (GC) relying on a single plea in law, infringement of Article 60(1)(a) EUTMR in conjunction with Article 8(1)(b) EUTMR. **Relevant public.** The relevant factor in determining the relevant public’s level of attention is not how the goods are purchased (in this case, according to the applicant, by reading the label) but the nature of the goods. As wines are everyday consumer goods, the level of attention is expected to be normal, not high (para. 24). **Distinctive element.** In a mark comprising a common forename, like Antonio, and a surname which is not common in the entirety of the relevant territory, that is to say the EU, the forename has a lower level of distinctiveness than the surname (para. 43). **Dominant element.** In the context of marketing wines, the grape leaves and ribbons do not dominate the image the relevant public retains of the earlier mark. The same is true for the presence of a coat of arms. It is rather the word element ‘RUTINI’ that dominates the perception of the earlier mark (paras 49-50). **Conceptual similarity.** Even though the surnames ‘RUBINI’ and ‘RUTINI’ are probably both of Italian origin, this is not sufficient for consumers to associate them and believe that the goods in question come from the same undertaking; thus they are not conceptually similar (paras 64-68). **Likelihood of confusion.** For identical goods, the visual and phonetic similarities between the signs, based on the similarity between the dominant and distinctive elements ‘RUTINI’ and ‘RUBINI’, suffice to conclude that there is LOC on the part of the relevant public (paras 73-76).



**T-694/17; SAVORY DELICIOUS ARTISTS & EVENTS (fig.); Link Entertainment, S.L.U v EUIPO;** Judgment of 11 July 2018; EU:T:2018:432; Language of the case: ES

EUTM	Earlier trade mark
	<p>AVORY</p>

The EUTM proprietor was granted the registration of the figurative mark above as an EUTM for services in Classes 35 and 41. An application for invalidity was filed pursuant to Article 60(1)(a) EUTMR in conjunction with Article 8(1)(b) EUTMR and Article 8(5) EUTMR and based on the word mark **AVORY** for services in the same Classes. The Cancellation Division (CD) upheld the application for invalidity and the Board of Appeal (BoA) dismissed the EUTM proprietor’s appeal. It found that there would be a likelihood of confusion between the marks for the relevant public considering the identity or similarity of services and the visual and phonetic similarities of the signs. The EUTM proprietor appealed to the General Court (GC) relying on a single plea in law, alleging infringement of Article 60(1)(a) EUTMR in conjunction with Article 8(1)(b) EUTMR. **Relevant public.** The services in Class 35 are aimed at a professional audience, while those in Class 41 are aimed at both professionals, with a high level of attention, and the general public, with a normal level of attention (para. 22). **Comparison of services.** Neither party has questioned that the services are all either identical or similar (para. 24). **Comparison of the signs.** On the **visual** level, the word ‘savory’ is the dominant element of the contested mark that will remain in the consumer’s memory because of its size and the fact that it is in bold characters. The other elements are small in size and occupy a secondary position in the sign. In addition, these secondary word elements describe part of the contested mark’s services, namely the event organisation services included in Classes 35 and 41. However, these elements are insignificant in the overall impression produced by the contested mark (para. 33). Given that the earlier mark and the dominant word element of the contested mark are formed by four visually identical letters (V, O, R, Y) located in the same order in the middle and at the end of the sign and with a similar letter (A), it can be concluded that the signs are visually similar to an average degree (paras 38-40). From a **phonetic** standpoint, the signs are phonetically similar for the same reason (paras 43, 44). On the **conceptual** level, no conceptual comparison can be made by the non-English-speaking public, without first examining whether the conceptual comparison is neutral for English speakers, who would attribute a meaning to the term ‘savory’ (para. 47). **LOC.** There is a likelihood of confusion at least as far as the non-English-speaking public is concerned (para. 55).



**T-584/17; PRIMART Marek Łukasiewicz (fig.) / PRIMA et al.;** *Przedsiębiorstwo Produkcyjno-Handlowe „Primart” Marek Łukasiewicz v EUIPO*; Judgment of 12 September 2018; EU:T:2018:530; Language of the case: EN

EUTM application	Earlier trade mark
	<p style="text-align: center;">PRIMA</p>

The applicant sought to register the figurative mark above as an EUTM for goods in Class 30. An opposition based, in particular, on the earlier Spanish word mark **PRIMA**, registered for goods in Class 30, was filed pursuant to Article 8(1)(b) EUTMR. The Opposition Division (OD) dismissed the opposition. The Board of Appeal (BoA) upheld the opponent’s appeal. It found that there was likelihood of confusion (LOC) taking into account that the goods at issue were all identical, highly similar or similar to an average degree, that the signs presented an average level of visual and above average level of phonetic similarity, the at most average level of attention of the relevant public and the average level of inherent distinctiveness of the earlier mark. The applicant filed an action before the General Court (GC) relying on a single plea in law, namely the infringement of Article 8(1)(b) EUTMR. **Relevant public’s attention.** Since the goods at issue are all common or everyday foodstuffs, of low value and high purchase frequency, there is nothing to justify stating the level of attention for each specific product (para. 38). The level of attention of the relevant public for the goods concerned is average or, taking into account the nature of the goods, even lower than average (para. 40). **Dominant and distinctive element of the EUTM application.** On account of its size and depiction as well as of its predominant position the word ‘PRIMART’ is the dominant and most distinctive element of the mark applied for (para. 53). The argument that the words ‘marek łukasiewicz’ correspond to the name of the applicant, appear in the name of its company and clearly indicate the origin of the goods has no bearing on whether the word ‘primart’ has a more distinctive and dominant character (para. 57). Since the earlier word mark **PRIMA** is entirely reproduced in the dominant and most distinctive element ‘PRIMART’ of the EUTM applied for, the marks are visually similar to an average degree and have a higher than average degree of phonetic similarity. The marks are not conceptually similar (paras 61-62, 71-74, 79). **Distinctive character of the earlier mark.** The argument concerning the weak distinctive character of the earlier mark must be declared inadmissible as it has been put forward for the first time before the court (para. 90), and, in addition, the meanings of ‘PRIMA’ accepted by the BoA were those alleged by the applicant before the Opposition Division (para. 91). **Independent distinctive role of the common element ‘PRIMA’ in the mark applied for.** The argument that, in order to preclude a likelihood of confusion, it is sufficient to rely on the absence of an independent distinctive role of an earlier mark in the mark applied for is unfounded. The individual assessment of each sign must be made depending on the individual circumstances of the case (paras 104-105). While the group of letters ‘prima’, which makes up the earlier mark in its entirety, does not play an independent distinctive role within the dominant element ‘primart’ of the mark applied for, it contributes significantly to the overall impression conveyed by the latter. The fact that ‘PRIMA’ does not play an independent distinctive role in the EUTM application is not such as to call into question the conclusion that there is LOC (paras 109-110).





**T-94/17; tigha / TAIGA; ACTC GmbH v EUIPO**; Judgment of 13 September 2018; EU:T:2018:539; Language of the case: EN. The applicant sought to register the word mark **tigha** as an EUTM for goods in, inter alia, Classes 18 and 25. An opposition based on the earlier word mark **TAIGA**, registered for goods in, inter alia, Classes 9, 18 and 25, was filed pursuant to Article 8(1)(b) EUTMR. The Opposition Division (OD) dismissed the opposition and the opponent filed an appeal. The Board of Appeal (BoA) partially upheld the appeal. It found that there was a likelihood of confusion (LOC) regarding the goods in Class 25, given their identity or similarity to the opponent's goods, and due to the fact that the signs were visually very similar, phonetically identical, at least for English-speaking consumers, and could not be associated with any concept for most of the relevant public. The applicant appealed to the General Court (GC), relying on two pleas in law: (i) infringement of Article 47(2) EUTMR and, (ii) infringement of Article 8(1)(b) EUTMR. The clothing goods referred to in the evidence of use have the same purpose, since they are intended to cover the human body, to conceal, adorn and protect it against the elements. They cannot be considered to constitute an independent category in relation to the goods in Class 25. The fact that they have particular weather-protection characteristics is, in principle, irrelevant, as the characteristics of the goods are not relevant to the definition of subcategories of the goods or services (para. 35). **Relevant public.** The relevant public consists of the general public and professionals with a high level of attention when purchasing the opponent's goods and an average level of attention with regard to the contested mark's *clothing, footwear, headgear and bags* in Class 25 (para. 39). **Comparison of the goods.** *Clothing and headgear* are identical. The contested mark's *footwear* and the opponent's *clothing and headgear* are similar. Those goods belong to the same class (Class 25), and may be produced by the same operators or sold together in the same sales outlets (para. 47). **Comparison of the signs.** (i) Both signs have five letters, of which four are in common, and in almost the same position (para. 55). The average consumer normally perceives a mark as a whole and does not engage in an analysis of its various details (para. 56). (ii) The signs are phonetically identical, at least for English-speaking consumers, to the extent that it is impossible, in the English language, to pronounce the letter 'h' placed in the middle of the contested sign. The pronunciation of the syllables 'ti' and 'tai' is identical (para. 58). (iii) The extract from the online encyclopedia Wikipedia does not demonstrate that the semantic connotations relating to the word 'taiga' are well-known facts likely to be known by consumers in all parts of the EU territory (para. 68). Even though it is likely that the word 'taiga' will be perceived as referring to the boreal forest in the north and east of the European continent, it has no specific and immediate meaning for average consumers in the southern parts of the European continent and English-speaking consumers (paras 70-71). **Likelihood of confusion.** Given that the goods concerned are usually sold in self-service shops where a consumer chooses the goods himself and that, therefore, the visual aspect is more important than the phonetic aspect, and taking into account the average distinctiveness of the earlier mark, the visual and phonetic similarity of the signs, their lack of clear and specific meaning for a significant part of the relevant public, and the similarity or identity between the goods concerned, there is LOC (paras 74, 78 and 80).





♦ [T-104/17](#); **apo (fig.) / DEVICE OF AN APPLE WITH A BITE (fig.) et al.**; *Apple Inc. v EUIPO*; Judgment of 13 September 2018; EU:T:2018:536; Language of the case: EN

EUTM application	Earlier trade mark
	

The applicant sought to register the figurative mark above as an EUTM for goods and services in Classes 9, 11 and 35. An opposition based on the earlier EU figurative mark above (registered for goods and services in Classes 1 to 12, 14 to 18, 20 to 33 and 35 to 45), the earlier EU word mark **APPLE** (registered for goods and services in Classes 2, 3, 5 to 8, 11, 12, 15, 20 and 43 to 45) and the EU word mark **APPLE** (registered for goods and services 9, 16, 35, 38, 41 and 42) was filed pursuant to Article 8(1)(b), Articles 8(4) and 8(5) EUTMR. The Opposition Division (OD) dismissed the opposition, insofar as it found, inter alia, no likelihood of confusion. The opponent filed an appeal. The Board of Appeal (BoA) dismissed the appeal, as it also found that the signs in question were dissimilar. The opponent filed an action with the General Court (GC) relying on four pleas in law: (i) infringement of Article 8(1)(b) EUTMR, (ii) infringement of Article 8(5) EUTMR, (iii) breach of the principle of the prohibition of *reformatio in pejus*, and (iv) infringement of Article 8(4) EUTMR. **Relevant public.** The relevant public is the EU public at large and professionals with specific knowledge, with an average to high degree of attention (para. 25). **Comparison of goods and services.** The goods and services are identical (para. 8). **Comparison of signs.** The earlier figurative sign and the contested figurative sign, each considered as a whole, show a certain degree of visual similarity. The existing differences do not suffice to rule out their common point, namely the fact that a significant part of the relevant public will immediately see them as representing an apple (para. 41). Regarding the earlier word marks, the signs create impressions that are dissimilar overall on the visual level. The mere fact that the two letters ‘a’ and ‘p’ coincide is not sufficient to counterbalance the clear differences between the contested earlier mark and the earlier word marks **APPLE** (para. 50). There is, at least for a significant part of the relevant public, a certain degree of phonetic similarity between the contested mark and the earlier word marks. In English, the pronunciation of the first syllable of the word ‘apo’ will be the same as that of the first syllable of the word ‘apple’. In addition, the word elements both have two syllables, and the first syllable will be stressed, whereas the second syllable will be swallowed. The result is a comparable rhythm and sound (paras 62-64). The signs are conceptually similar to the extent that all of them evoke the concept of an apple (para. 75). The word element ‘apo’ does not have a meaning, in most languages, for the relevant public (para. 71). Therefore, the BoA erred in finding that the signs were different (para. 77). **Scope of proceedings.** Given that the BoA did not conduct an assessment nor did it take a position on the other conditions regarding the grounds for refusal, the contested decision may be annulled without it being necessary to examine the other pleas (para. 78).





♦ [T-418/17](#); **Safari Club / WS Walk Safari (fig.)**; *Eduard Meier GmbH v EUIPO*; Judgment of 13 September 2018; EU:T:2018:540; Language of the case: EN

EUTM application	Earlier trade mark
<p><b>Safari Club</b></p>	

The applicant sought to register the word mark **Safari Club** as an EUTM for goods and services in, inter alia, Classes 18 and 25. An opposition based on the earlier Italian figurative mark above, registered for certain goods and services in Classes 18 and 25 was filed pursuant to Article 8(1)(b) EUTMR. The Opposition Division (OD) upheld the opposition and the applicant appealed. The Board of Appeal (BoA) dismissed the appeal. It found that, given the average degree of conceptual and phonetic similarity of the signs, their visually similarity, and the average level of attention of the relevant consumer, there was a likelihood of confusion (LOC) for all the goods concerned. The applicant filed an action before the General Court (GC), relying on a single plea in law: infringement of Article 8(1)(b) EUTMR. **Relevant public.** The relevant public is made up of the Italian general public with an average level of attention, given the nature of the goods (inexpensive items purchased on a regular basis) (para. 21). **Comparison of the goods.** The goods are identical or similar to varying degrees (para. 21). **Dominant and distinctive element.** The element ‘WS’ of the earlier mark would be perceived as merely an abbreviation of the word element ‘walk safari’, and therefore, cannot constitute the distinctive and dominant element of that sign (para. 37). **Comparison of the signs.** (i) The signs are visually similar, at least to a low degree, insofar as the graphical representation of the earlier mark (a frame and a slightly stylised font) will not detract the relevant public’s attention from its word elements (para. 44). However, they are visually different regarding hunting-related goods, since the common word element ‘safari’ will be accorded less importance, given that it alludes to those goods. Accordingly, visual attention will be drawn to the other elements of the signs, inter alia, the element ‘walk’ of the earlier mark and the element ‘club’ of the contested mark, two completely different words (para. 45). (ii) The signs are phonetically similar, at least to an average degree, since three of their four syllables are identical, and since the element ‘WS’ of the earlier mark, being perceived as an abbreviation, would not be pronounced (para. 50). As regards hunting-related goods, the degree of similarity must be regarded as low, insofar as the common word element ‘safari’ alludes to those goods (para. 48). (iii) The signs are conceptually similar, since the common word ‘safari’ conveys an identical concept, despite the weak conceptual differences between the words ‘walk’ and ‘club’ (para. 53). However, as regards hunting-related goods, the common element ‘safari’ will have only weak distinctive character for the relevant public who will pay more attention to the differences between the signs, namely, the element ‘walk’ of the earlier mark, and the element ‘club’ of the contested mark, which have different semantic content (para. 54). **Likelihood of confusion.** Given the average distinctiveness of the earlier mark, the identity or similarity of the goods and the similarity of the signs, there is LOC (para. 61). However, there is no LOC for hunting-related goods: given the weak distinctive character of the common word element ‘safari’, the visual differences between the other elements will prevail in their overall impression (para. 65). Those visual differences are especially crucial, since the hunting-related goods are usually sold in self-service shops in which the consumer chooses the product him- or herself and must, accordingly, rely on his or her recollection of the mark applied to the product (para. 64).



**T-435/17; HIPANEMA (fig.) / Ipanema (fig.) et al.; Grendene, SA v EUIPO;** Judgment of 25 September 2018; EU:T:2018:596; Language of the case: EN

IR designating the EU	Earlier trade marks
	

The trade mark proprietor obtained an international registration (IR) for the figurative mark above for *jewelry; jewelry products, precious stones; timepieces and chronometric instruments; precious metals and alloys; works of art of precious metal; jewelry cases [caskets]; boxes of precious metal; watch cases, bracelets, chains, springs or glasses; key rings [trinkets or fobs]; statues or figurines (statuettes) of precious metal; cases or presentation cases for timepieces; medals* in Class 14. An opposition based on the earlier EUTMs and Spanish trade mark seen above was filed pursuant to Article 8(1)(b) EUTMR. The Opposition Division (OD) dismissed the opposition on the ground that the goods and services at issue were clearly dissimilar. The opponent filed an appeal but the Board of Appeal (BoA) dismissed it confirming the OD’s decision in its entirety. The opponent filed an action with the General Court (GC), relying on a single plea in law: infringement of Article 8(1)(b) EUTMR. **Failure to take into account ‘tacit recognition’.** The applicant failed entirely to establish ‘recognition’ by the intervener, even ‘tacit’ recognition, of any form of similarity between the goods at issue. It was therefore not necessary for the BoA to take into account such non-existent ‘tacit recognition’ and to apply the principle of *venire contra factum proprium non valet* with the aim of invalidating the proprietor’s arguments relating to the lack of similarity between the goods at issue (paras 38-39). **Error in the comparison of the goods. Comparison of the specified goods *jewelry; jewelry products; timepieces and chronometric instruments; bracelets; chains; medals* with the goods in Class 25 specified in the earlier marks.** As the search for a certain aesthetic harmony in clothing is a common feature throughout the fashion and clothing sector, it is too general a factor to justify a finding that all the goods concerned are complementary (para. 56). Even if it were to be assumed that it has become usual for manufacturers of goods protected by earlier marks to manufacture the specified goods and thus to exploit their commercial success by placing their trade marks on a wide range of goods, the fact remains that the opponent has not established that consumers were necessarily informed of such a practice and normally expected that the same undertaking could be responsible for the manufacture of the various goods at issue which, *prima facie*, are not related and do not fall within the same family of goods (para. 59) The BoA was thus entitled to conclude that the goods in comparison are different (para. 66). **Comparison of the other specified goods.** All the relevant factors of the relationship between the goods at issue, namely their nature, intended purpose, distribution channels and commercial origin had been taken into account by the OD (para. 68). The BoA was fully entitled to adopt the OD’s conclusion that the goods specified in this ground for complaint are different from the goods protected by the earlier marks, in particular footwear (para. 70). The BoA was right to conclude that *precious stones; precious metals and alloys; works of art of precious metal; jewelry cases [caskets]; boxes of precious metal; watch cases, springs or glasses; key rings [trinkets or fobs]; statues or figurines (statuettes) of precious metal; cases or presentation cases for timepieces* covered by the



mark applied for differ from the goods protected by the earlier marks (para. 74). **Comparison with the services listed in the earlier marks.** The BoA was right to conclude that the nature, intended purpose and method of use of the specified goods in Class 14 are entirely different from those of the services protected by the earlier mark and that they are not in competition with each other, nor are they functionally or aesthetically complementary (para. 77). **National decision.** The essential factual elements of the national decision relied on differ substantially from the present case in terms of the parties, the earlier mark and the nature of the proceedings, namely infringement proceedings rather than opposition proceedings (para. 80). **Failure to apply the principle of interdependence.** The BoA did not err in concluding that the goods at issue were different and were not even slightly similar. That lack of similarity is sufficient to rule out any likelihood of confusion between the marks at issue (para. 86).

**T-182/17; AKANTO / KANTOS**; *Novartis v EUIPO*; Judgment of 25 September 2018; EU:T:2018:592; Language of the case: EN. The applicant sought to register the word mark **AKANTO** as an EUTM for *pharmaceutical preparations, excluding pharmaceutical preparations for the treatment of burns, scars, injuries and consequences of surgical intervention* in Class 5. An opposition based on the earlier word mark **KANTOS**, registered for *pharmaceutical products for human use for sale with a medical prescription*, was filed pursuant to Article 8(1)(b) EUTMR. The Opposition Division (OD) dismissed the opposition as it found that there was no likelihood of confusion. The opponent appealed. The Board of Appeal (BoA) upheld the appeal. It found that, for the identical goods, the strong visual and phonetic similarities between the signs created a likelihood of confusion between the marks in the mind of the relevant public. The applicant filed an action before the General Court (GC), relying on a single plea in law: infringement of Article 8(1)(b) EUTMR. **The relevant public.** The relevant public is composed of the public at large as well as of a specialised public in the pharmaceutical and medical fields, living in the European Union and displaying a high degree of attentiveness (not disputed) (para. 22). **Comparison of the goods.** The goods are identical (not disputed) (para. 25). **Comparison of the signs.** Since the marks have five out of their six letters in common, and those five letters are placed in the same sequence, they are visually highly similar (paras 33-35). Despite the phonetic differences due to the different number of syllables in each word and to the fact that the pronunciation of the beginnings and endings of the marks, by reason of the ‘a’ and the ‘s’ sounds, respectively, differs, the identity in sound of the element ‘kanto’ implies that the marks are phonetically highly similar (paras 41-42). A conceptual comparison of the marks is not possible as the general public will not perceive a specific meaning in the contested sign **AKANTO** even if ‘acanto’ refers to the plant *Acanthus mollis*, used for medicinal purposes (para. 48). Although the Office must take into account the decisions already taken in respect of similar applications, such as those submitted by the applicant, the manner in which the principles of equal treatment and sound administration are applied must, however, be consistent with respect for legality (para. 57). There is a likelihood of confusion in the mind of the relevant public, even though that public displays a high level of attentiveness (para. 65).

**T-712/17; GN Laboratories / GNC et al.**; *Christos Ntolas v EUIPO*; Judgment of 27 September 2018; EU:T:2018:618; Language of the case: EN. The applicant sought to register the word mark **GN Laboratories** as an EUTM for goods and services in Classes 5, 29 and 30. An opposition based on the earlier word mark **GNC**, registered, inter alia, for *protein for human consumption* in Class 5 and *milk products* in Class 29, was filed pursuant to Article 8(1)(b) EUTMR. The Opposition Division (OD) upheld the opposition, finding likelihood of confusion (LOC). The applicant filed an appeal, which was dismissed by the Board of Appeal (BoA). The BoA found that there was LOC, given the average degree of



similarity between the marks and the identity or similarity of the goods covered by them, the weak distinctive character of the word 'laboratories' and the normal degree of distinctiveness of the earlier mark. The applicant filed an action with the General Court (GC), relying on a single plea in law: infringement of Article 8(1)(b) EUTMR. **Relevant public.** The relevant public consists of consumers of nutritional and medicinal products and of practitioners within the EU, with an above average degree of attention (para. 22). **Comparison of the goods.** The contested goods in Class 5 include or may include the opponent's goods containing protein for human consumption, and therefore, they are identical. (para. 23). Regarding the goods in Classes 29 and 30, the protein-based dietetic foodstuffs for non-medical purposes and *albumen for culinary purposes*, being protein, are identical to the opponent's *protein for human consumption*. As regards the other dietetic foodstuffs (with a base of fats, fatty acids, carbohydrates, etc.), they are similar to the opponent's goods, since they meet the same needs, are aimed at the same public and distributed through the same channels (para. 25). As regards *edible oils* covered by Class 29 of the contested mark, they may be used interchangeably with *butter*, covered by the general category of *milk products* in Class 29 of the earlier mark, and, therefore, are similar (para. 26). **Comparison of the signs.** The term 'laboratories' is weakly distinctive, since it refers to sophisticated production processes based on science and therefore creates an impression relating to the quality and effectiveness of the goods manufactured through chemical processes. As such, that term is not of a nature that could neutralise the visual and phonetic similarities between the signs. Likewise, the additional letter 'C' in the earlier mark is not of a nature that could call into question the visual and phonetic similarity resulting from the common letter sequence GN. The marks do not present any conceptual similarity, since the common letter sequence GN does not convey any particular message (para. 28-30). **LOC.** Given that the marks at issue are moderately similar and the goods covered by them are partly similar and partly identical, the likelihood that the public would believe that the goods in question come from the same undertaking or from economically linked undertakings cannot be ruled out either because of the presence of the letter 'C' in the earlier trade mark or because the term 'laboratories' forms part of the mark applied for. This conclusion is not affected by the higher level of attention that may be shown by some consumers of goods in Classes 5 or 29 (para. 33).

**T-448/17; SEVENFRIDAY / SEVEN et al.**; *Sevenfriday AG v EUIPO*; Judgment of 27 September 2018; EU:T:2018:617; Language of the case: EN. The applicant sought to register the word mark **SEVENFRIDAY** as an EUTM for goods in Classes 18 and 25. An opposition based on the earlier word mark **SEVEN** registered for goods in, inter alia, Class 18, was filed pursuant to Article 8(1)(b) and (4) EUTMR. The Opposition Division (OD) upheld the opposition. The applicant appealed. The Board of Appeal (BoA) dismissed the appeal finding that the low degree of similarity between the signs was offset by the identity between the goods. It concluded that there was a likelihood of confusion (LOC) between the marks on the part of the relevant public. The applicant brought an action before the General Court (GC), relying on a single plea in law: infringement of Article 8(1)(b) EUTMR. **Relevant public and comparison of the goods.** The relevant public consists of the general public of the EU, and the goods in Class 18 covered by the marks are identical (para. 23). **Comparison of the signs.** The signs are visually similar to an average degree due to their common word element 'seven' but due to the second element of the contested mark, namely 'friday', they differ in length (para. 34). The common element 'seven', appearing at the beginning of the contested mark has a greater impact in the overall visual impression, since the consumer generally pays greater attention to the beginning of a word mark than to the end (para. 35). The signs are phonetically similar to an average degree: the word 'seven' appears in full in the two signs and is pronounced identically. In addition, the attention of the relevant public tends to be directed in particular



to the beginning of a word, which is consequently the element most easily remembered (para. 41). The signs have some conceptual similarity: they have the semantic content of the element ‘seven’ in common, which refers to the number 7. That similarity cannot be ruled out by the mere presence, in the sign **SEVENFRIDAY**, of the word ‘Friday’, which conveys an independent meaning and does not change that of the word ‘seven’ (para. 49). **Distinctiveness of the word ‘seven’**. The word ‘seven’ must be regarded as having an average degree of inherent distinctiveness, since the opponent failed to prove that the word ‘seven’ had a particular meaning in relation to the goods, nor that it had a link with them or was commonly used in the sector concerned (para. 65). In any event, any finding of weak distinctive character for the earlier trade mark does not preclude LOC (para. 69). **LOC**. Given the average degree of similarity of the signs, the identity between the goods, and the average, or even low, distinctiveness of the earlier mark, there is LOC.

[T-449/17](#); **SEVENFRIDAY / SEVEN et al.**; *Sevenfriday AG v EUIPO*; Judgment of 27 September 2018; EU:T:2018:612; Language of the case: EN



EUTM application	Earlier trade marks
SEVENFRIDAY	SEVEN 

The applicant sought to register the word mark **SEVENFRIDAY** as an EUTM for goods in Classes 9, 16 and 18. An opposition based on the earlier EU word mark **SEVEN** registered for goods in Classes 16 and 18 and the international registration of the figurative mark above was filed pursuant to Article 8(1)(b) and (4) EUTMR. The Opposition Division (OD) upheld the opposition. The applicant appealed. The Board of Appeal (BoA) dismissed the appeal finding likelihood of confusion (LOC). The applicant brought an action before the General Court (GC), relying on a single plea in law: infringement of Article 8(1)(b) EUTMR. **Relevant public and comparison of the goods**. The relevant public consists of the general public of the EU and the goods in Classes 9, 16 and 18 are identical, with the exception of *money holders* that are highly similar to *holders for cheque books* (para. 23). **Comparison of the signs**. The signs are visually similar to an average degree due to their common word element ‘seven’, but due to the second element of the contested mark, namely ‘friday’, they differ in length (para. 34). The common element ‘seven’ at the beginning of the contested mark has a greater impact in the overall visual impression, since the consumer generally pays greater attention to the beginning of a word mark (para. 35). Regarding the earlier figurative mark, there is a low degree of similarity due to the differences flowing from the element ‘friday’, from the number 7 placed at the beginning of the earlier figurative mark and, accordingly, from the length of the signs (para. 42). The signs are phonetically similar to an average degree: the word ‘seven’ appears in full in the two signs and is pronounced identically. In addition, the attention of the relevant public tends to be directed in particular to the beginning of a word, which is consequently the element most easily remembered (para. 47). Furthermore, it is unlikely that the relevant public will pronounce the number 7 placed at the beginning of the earlier figurative mark, so it will not be pronounced as ‘seven seven’ or ‘seventy seven’ (para. 50). The signs have some conceptual similarity: they have the semantic content of the element ‘seven’ in common, which refers to the number 7. That similarity cannot be ruled out by the mere presence, in the sign **SEVENFRIDAY**, of the word ‘Friday’, which conveys an independent meaning and does not change that of the word ‘seven’ (para. 59). That finding is not called into question by the additional presence of the number 7 at the beginning of the earlier figurative mark, which, on the contrary, only strengthens the conceptual similarity



(para. 63). **Distinctiveness of the word ‘seven’.** The word ‘seven’ must be regarded as having an average degree of inherent distinctiveness, since the opponent has not proved that the word ‘seven’ had a particular meaning in relation to the goods, nor that it had a link with them or was commonly used in the sector concerned (para. 79). Having regard specifically to the earlier figurative mark, the distinctive character is slightly reinforced by the figurative elements, as well as by the use of numbers and letters (para. 82). In any event, any finding of weak distinctive character for the earlier trade marks does not preclude LOC (para. 83). **LOC.** Given the average degree of similarity of the signs, the identity between the goods, and the average, or even low, distinctiveness of the earlier marks, there is LOC.

♦ [T-186/17](#); **WALLAPOP (fig.) / WALA W (fig.) et al.**; *Unipreus, SL v EUIPO*; Judgment of 3 October 2018; EU:T:2018:640; Language of the case: ES

EUTM application	Earlier trade mark
	

The intervener sought to register the figurative sign above for services in Class 35. An opposition based on the earlier mark above, registered for services in Class 35, was filed by the applicant pursuant to Article 8(1)(b) EUTMR. The Opposition Division (OD) rejected the opposition, so the applicant appealed against the OD’s decision. The Board of Appeal (BoA) dismissed it confirming that the relevant territory was Spain and that the signs were only weakly similar. The applicant filed an action before the General Court (GC), relying on a single plea in law: infringement of Article 8(1)(b) EUTMR. **Comparison of services.** The distribution channels of the contested services are, at the very least, weakly similar (para. 38). The mark applied for does not concern sales services per se, but intermediation or online market management services for buyers and sellers of goods and services, including providing commercial information relevant to the conduct of sales (para. 41). The nature, destination and use of the services are not necessarily identical insofar as the applicant’s retail services are provided directly between the seller and the buyer through access to fixed stores or through the seller’s usual website. The intervener’s services, however, are provided through a mobile application that connects third party buyers and sellers who negotiate prices and purchase conditions between themselves. The contested services facilitate retail sales between buyers and sellers. Consequently, the destination and use of the services in question should not have been considered absolutely different by the BoA, but rather, instead, not very similar, (para. 44). It cannot be excluded that the mark applied for may be used to connect professional sellers with consumers, contrary to what the BoA stated in its contested decision (para. 47). The BoA therefore wrongly held that the services in question were not aimed at the same consumers (para. 49). It should also be noted that the services are weak competitors. Indeed, as the applicant claims, consumers can analyse the offer for the same product both on the ‘www.walashop.com’ website and on the ‘www.wallapop.com’ website (para. 50). The services in question are, at the very least, weakly similar, therefore, the BoA wrongly deemed that these services were different (para. 54).

[T-374/17](#); **Cuervo y Sobrinos LA HABANA 1882 (fig.) / CUERVO Y SOBRINO et al.**; *Cuervo y Sobrinos 1882, S.L. v EUIPO*; Judgment of 10 October 2018; EU:T:2018:669;



Language of the case: ES

EUTM	Earlier trade marks
	<p style="text-align: center;"><b>CUERVO Y SOBRINO</b></p>

The EUTM proprietor obtained registration of the figurative mark above as an EUTM for *jewellery, horological and chronometric instruments* in Class 14, *pens, pencils* in Class 16, *wallets, purses, briefcases* in Class 18 and *clothing, footwear, headgear* in Class 25. An invalidity application was filed pursuant to Article 59(1)(b) EUTMR and Article 60(1)(a) EUTMR in conjunction with Article 8(1)(b) EUTMR, based on two Spanish word marks, both for the sign **CUERVO Y SOBRINO**, for *jewellery, hardware, silverware, imitation jewellery, watches, accessories and supplies for watches* in Class 14 and *stylographs, ballpoint pens, mechanical pencils and office requisites* in Class 16. The Cancellation Division (CD) upheld the invalidity application on the basis of Article 59(1)(b) EUTMR. The proprietor appealed. The Board of Appeal (BoA) partially upheld the appeal insofar as the CD had upheld the application for a declaration of invalidity for the goods in Classes 18 and 25. It found, first, that there was a likelihood of confusion (LOC) with regard to the goods in Classes 14 and 16 since the signs were visually and phonetically very similar and the goods identical; second, that there was no LOC for the goods in Classes 18 and 25 since the goods were not similar; and, third, that the proprietor had not acted in bad faith, since the registration of the contested mark was not incompatible with the contractual relations existing between the parties and did not cause prejudice to the interests of the invalidity applicant. The proprietor brought an action before the General Court (GC), relying on one single plea in law: infringement of Article 60(1)(a) EUTMR in conjunction with Article 8(1)(b) EUTMR. It submits that the signs at issue are not similar and that LOC is therefore also excluded for the goods in Classes 14 and 16. The invalidity applicant brought a cross-claim, relying on two grounds: (i) infringement of Article 60(1)(a) EUTMR in conjunction with Article 8(1)(b) EUTMR and, (ii) infringement of Article 59(1)(b) EUTMR. It claims that the goods in Classes 18 and 25 are similar to the earlier marks' goods and that there is therefore a likelihood of confusion also with regard to those goods. It furthermore contends that the proprietor acted in bad faith when the contested mark was filed. **The EUTM proprietor's action. Comparison of the signs.** Although in marks composed of word and figurative elements, the former must not always be considered more distinctive than the latter, in this case, especially due to its larger size and central position, the element 'Cuervo y Sobrinos' clearly has a bigger impact on the overall impression of the contested mark, as compared to the shield in the upper part of the sign and the descriptive word element 'La Habana 1882' in the lower part. As the dominant element of the contested mark 'Cuervo y Sobrinos' is almost identical to the purely denominative earlier trade marks 'Cuervo y Sobrino'. Indeed, the conflicting marks, as a whole, are very similar visually and phonetically with the result that there is LOC between them for the identical goods in Classes 14 and 16. Such a conclusion cannot be called into question by the fact that the level of attention of the relevant public is higher for the goods in Class 14 (paras 24-30). Accordingly, the proprietor's single plea must be rejected as unfounded (para. 31). **The invalidity applicant's cross-claim. Comparison of the goods.** The contested goods in Class 18,







namely *wallets, purses and briefcases*, are different in nature, purpose and use to those of the earlier marks in Classes 14 and 16 and are not in competition or complementary. They are, therefore, not similar (para. 37). The contested goods in Class 25, namely *clothing, footwear, headgear*, cannot be regarded as similar to the invalidity applicant's goods in Classes 14 and 16 either (paras 35-36). This appreciation is not questioned by the fact that the parties had concluded a licence agreement on 14 November 2002 whereby the invalidity applicant granted authorisation to the proprietor to use the name CUERVO Y SOBRINO exclusively for wristwatches. The existence of such an agreement does not mean that consumers will consider it common practice for the goods covered by the contract to be marketed under the same brand. Furthermore, accepting that the existence of the licence agreement of 14 November 2002 is capable of establishing, on its own, a similarity between the goods covered by that contract would imply an absurd conclusion that, under certain circumstances, any product may be considered similar to any other, regardless of the characteristics of these goods. Therefore, the invalidity applicant's first ground must be rejected as unfounded. (paras 38-44). **Bad faith.** The contested mark was registered for goods in four classes, namely Classes 14, 16, 18 and 25. However, as regards the goods in Classes 14 and 16, the cross-claim has become devoid of purpose given that the annulment of the contested mark for those goods is confirmed by the court ruling on the only plea of the EUTM proprietor (paras 65-66). As regards the contested goods in Classes 18 and 25, the fact that the EUTM proprietor was already the owner of several earlier CUERVO Y SOBRINOS Italian and international marks at the time of filing the EUTM application suggests that the filing of the application for registration of the contested mark was part of a plausible commercial logic (paras 68-69). Furthermore, the licence agreement signed on 14 November 2002 for 15 years was presumably in force at the time of filing the contested mark, namely on 17 May 2012. Such an agreement restricted the licence exclusively to wristwatches and expressly prohibited the EUTM proprietor from using the CUERVO Y SOBRINO name for any other product or activity. However, the Regulation and Directive do not forbid, in principle, the registration of another person's trade mark for different goods. The proprietor's bad faith can therefore not be deduced from the mere existence of a contractual prohibition as the one included in the licence agreement. Having regard to all these factors, it must be held that, as regards the goods in Classes 18 and 25, the applicant's bad faith at the time of lodging the contested mark has not been proved (paras 70-74). The action and the cross-claim are both unfounded.

**T-444/17; life coins / LIFE et al.; CompuGroup Medical AG v EUIPO;** Judgment of 15 October 2018; EU:T:2018:681; Language of the case: DE. The applicant sought to register the word mark **LIFE COINS** for goods and services in Classes 9, 38, 41, 42, 44 and 45. An opposition based on the earlier EU word mark **LIFE**, registered for goods and services in Classes 7 to 11, 16, 28 and 42, was filed pursuant to Article 8(1)(b) EUTMR. The Opposition Division (OD) upheld the opposition for all the goods and services concerned, with the exception of *services of a medical laboratory* in Class 42, which were considered dissimilar to all the goods and services of the earlier mark. The applicant filed an appeal against the OD's decision. The Board of Appeal (BoA) partially annulled the OD's decision for the services of *collection and distribution of news (press agencies)* in Class 38, which were found to be at most remotely similar to the goods and services of the earlier mark and in any event not sufficiently similar to cause a likelihood of confusion (LOC). As for the remainder, the BoA confirmed the OD's finding of LOC. The applicant filed an action with the General Court (GC), relying on a single plea in law: infringement of Article 8(1)(b) EUTMR. **Relevant public.** The BoA had correctly held that the goods and services included in Classes 9 and 38 were intended for the general public and traders, who paid an average level of attention and were reasonably well informed and reasonably observant



and circumspect, while the services covered by Class 42 were primarily intended for traders with a level of attention slightly higher than average (paras 28-29). **Comparison of the goods and services.** The BoA had rightly found that the services included in Class 38 were telecommunications services, which were associated with the field of information technology required for their supply. It had also rightly found that, due to the increasing interdependence of the markets for computer hardware and software, on the one hand, and telecommunications services, on the other, there was a complementary relationship and similarity between the services in question and devices used for telecommunications purposes (para. 37). **Comparison of the signs.** Regarding visual and phonetic similarity, the BoA had concluded that the signs in conflict were identical in their verbal element, ‘life’ (paras 46 and 49). The BoA had been right to consider that the signs were similar visually, phonetically and, at least for the English-speaking part of the relevant public, conceptually (paras 54-61). **LOC.** The word ‘life’ was not descriptive of the goods and services for which the earlier trade mark had been registered (para. 70). The BoA had been right to conclude that there was a LOC between the signs for the average consumer regarding the goods and services included in Classes 9, 38 and 42, with the exception of the services of *collection and distribution of news (press agencies)* in Class 38 (para. 74).

♦ [T-548/17](#); **ANOKHI (fig.) / Kipling (fig.) et al.**; *VF International Sagl v EUIPO*; Judgment of 16 October 2018; EU:T:2018:686; Language of the case: EN

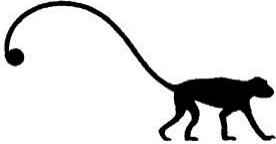
EUTM application	Earlier rights
	<p data-bbox="938 1061 1193 1093">EUTM No 165 845:</p>  <p data-bbox="927 1294 1209 1326">EUTM No 1 459 098:</p> 

An application for registration of an EU trade mark was filed for the figurative sign above for goods in Classes 9, 14, 18 and 25. The applicant filed an opposition based on the earlier EU trade marks above, pursuant to Articles 8(1)(b) EUTMR and Article 8(5) EUTMR. The Opposition Division (OD) rejected the opposition in its entirety on the grounds that, although the signs were similar, they were not sufficiently so as to lead to a likelihood of confusion (LOC) in the absence of proof of enhanced distinctiveness of the earlier marks, even in relation to identical goods. In the absence of convincing proof of reputation, the opposition was also dismissed under Article 8(5) EUTMR. On appeal against the OD’s decision, the Board of Appeal (BoA) found that the marks at issue were not visually, phonetically or conceptually similar, and thus, the opposition had to be dismissed under Article 8(1)(b) EUTMR without a global assessment of the LOC. As regards Article 8(5) EUTMR, the BoA confirmed the OD’s findings that reputation was not proven. The opponent filed an action before the General Court (GC), relying on three pleas in law: (i) infringement of Article 8(1)(b) EUTMR, (ii) infringement of Article 8(5) EUTMR and (iii) infringement of Article 85(1) EUTMR. The GC annulled the BoA’s decision in accordance with the following



reasoning. **Similarity of the signs — dominant and distinctive elements.** Contrary to the opponent's contention, the BoA did not deny the distinctiveness of the representation of a monkey in the composite signs, nor did it find such figurative elements negligible in the overall impression of the signs or that the word elements dominated the overall impression of the composite signs. Indeed, the BoA correctly found that, for composite signs, the verbal element usually has a greater impact than the figurative one, as it is easier to refer to the goods in question by reference to the word elements of the marks (paras 27, 29, 55, 57). **Visual comparison.** The BoA erred in finding that the marks were visually dissimilar. The differences in the word elements and in certain figurative details do not offset the overall visual similarity resulting from the representations of slender, long-tailed monkeys shown walking in profile, present in the marks (paras 37-39, 65-68). **Phonetic comparison.** The BoA correctly found the marks to be phonetically dissimilar with regard to the earlier composite mark (para. 41). However, it erred in coming to the same conclusion with regard to the earlier figurative-only mark, where it should have found that a phonetic comparison was not possible (paras 74-76). **Conceptual comparison.** The BoA erred in finding that the marks were not conceptually similar. As the figurative elements are not negligible in the overall impression of the marks, it erred in finding that the relevant public would not perceive a concept conveyed by those elements. As the marks at issue use images with an analogous semantic content, they are conceptually similar (paras 46-49, 82-85). **Overall similarity.** It follows that the BoA erred in finding no similarity between the marks at issue and in considering Article 8(1)(b) EUTMR inapplicable (paras 52, 88, 89).

♦[T-171/17](#); **KIMIKA / KAMIK**; *M & K Srl v EUIPO*; Judgment of 16 October 2018; EU:T:2018:683; Language of the case: EN. The applicant sought to register the word mark **KIMIKA** for goods in Classes 14, 18 and 25. An opposition based on the earlier EU word mark **KAMIK** registered for goods in Class 25 was filed pursuant to Article 8(1)(b) EUTMR. The applicant, pursuant to Article 47(2) and (3) EUTMR, submitted a request for the opponent/intervener to submit proof of genuine use. The intervener then provided various documents in order to show that the earlier trade mark had indeed been genuinely used. The Opposition Division (OD) upheld the opposition and the applicant filed an appeal against the OD's decision. The Board of Appeal (BoA) dismissed the appeal as it found that there was a likelihood of confusion (LOC). The applicant filed an action with the General Court (GC), relying on two pleas in law: (i) infringement of Article 47(2) and (3) EUTMR read in conjunction with Article 18(1) and (2) EUTMR and (ii) infringement of Article 8(1)(b) EUTMR. **Comparison of the goods.** The BoA did not err in law in concluding that the goods for which genuine use of the earlier mark had been proved, namely *footwear*, were (a) identical with *footwear* in Class 25 and (b) similar at least to an average degree to *clothing* and *headgear* in Class 25 (paras 61-72). It is common ground that *sports shoes* are not exclusively sold in specialist sports shops, but may also be offered for sale in the same retail establishments as those that sell *footwear* and *clothing*, including supermarkets, department stores and even high-end shopping centres (para. 70). In addition, potential differences between the distribution channels for goods in Class 25 do not constitute an argument likely to negate the common purpose of goods in that class (para. 71). **Comparison of the signs. Visual and phonetic comparison.** The two signs in question have the same first letter, 'k', and have the letter 'k', the syllable 'mik' and the letter 'a' in common, the first two of which occupy the same position in their respective words. The verbal element 'mik' is entirely reproduced in the mark applied for. The BoA was correct to conclude that the signs were visually similar to an average degree (paras 84 and 85). Although the vowel sequence is reversed, it should be considered that, due to the coincidence of the letter 'k' and the letter sequence 'm', 'i' and 'k', there is at least an average degree of phonetic similarity between the two signs (para. 86). In conclusion, the signs in question are visually and phonetically similar at least to an average degree, due to



the presence of several alphabetical elements common to both signs (para. 88). **Conceptual comparison.** The BoA was fully entitled to consider, and adequately reasoned, that, since neither of the signs had a clear and specific meaning for the relevant public in the European Union, a conceptual comparison was, in essence, impossible (paras 89-101). **LOC.** The BoA did not make an error of assessment in concluding that there was, pursuant to Article 8(1)(b) EUTMR a LOC on the part of the relevant public between the mark applied for and the earlier trade mark (paras 102-109).

**T-788/17; MicroSepar / SEPARSolidaria (fig.);** *Andreas Szabados v EUIPO*; Judgment of 17 October 2018; EU:T:2018:691; Language of the case: DE

EUTM application	Earlier trade mark
MicroSepar	

The applicant sought to register the word mark **MicroSepar** as an EUTM for services in Class 42. An opposition based on the earlier Spanish figurative mark above, registered for services in Classes 42 and 44, was filed pursuant to Article 8(1)(b) EUTMR. The Opposition Division (OD) upheld the opposition and the applicant appealed. The Board of Appeal (BoA) dismissed the appeal. The applicant went on to file an action before the General Court (GC), relying on a single plea in law: infringement of Article 8(1)(b) EUTMR. **Relevant public.** Regarding the nature of the services, the relevant public is composed of the general public and professionals, both of whom will be attentive (para. 21). Since the earlier mark is a Spanish trade mark, the relevant territory is Spain (para. 22). **Comparison of the services.** The services are identical, since both include *veterinary services, medical services and chemical laboratory services* (para. 25). **Comparison of the signs.** The signs are visually similar to an average degree due to their common distinctive element ‘separ’. This similarity is not counteracted by the red circle in the earlier mark or by the other verbal elements (para. 30). The different position of the element ‘separ’ in the two marks does not alter its distinctive character or the perception of the public regarding the coincidence of the term in both marks (para. 42). Phonetically, the marks are similar given the coincidence of the element ‘separ’. The weak elements ‘Micro’ and ‘Solidaria’ will not neutralise the phonetic similarity (paras 31-32). Neither ‘MicroSepar’ nor ‘SEPARSolidaria’ has a concrete meaning in Spanish. Moreover, ‘Micro’ and ‘Solidaria’ are weak, non-distinctive components of the marks: ‘Micro’ is a prefix used in many Spanish words in the medical, technical and scientific fields and confers on the compound form the sense of something small or localised or relatively small in size, while ‘Solidaria’ is an expression that is commonly used to denote objectives that are aligned with the community as a whole (paras 33-34). The website ‘deepI’, adduced by the applicant, is not an online dictionary but a search engine that merely provides a mechanical translation of words and elements without taking into account the context in which these are used. Therefore, it cannot prove that the element ‘separ’, a term which does not exist in the Spanish language and is not listed in Spanish dictionaries, would have any meaning for the relevant public (para. 35). Even if it did have a meaning, the marks would only be conceptually similar to a low degree because of their common element ‘separ’ (para. 36). **Likelihood of confusion.** Given the common distinctive element ‘separ’, the visual and phonetic (and potentially conceptual) similarity of the signs, as well as the identity of the services and the degree of attention of the relevant public, there is LOC (para. 40).



♦[T-533/17](#); **nuuna (fig.) / NANU et al.**; *Next design + produktion GmbH v EUIPO*; Judgment of 18 October 2018; EU:T:2018:698; Language of the case: DE

EUTM application	Earlier trade marks
	<b>NANU-NANA</b> <b>NANU</b>

The applicant sought to register the figurative mark above as an EUTM for, inter alia, *paper, cardboard and goods made from these materials, not included in other classes; printed matter; bookbinding material; photographs; stationery; adhesives for stationery or household purposes; artists' materials; paint brushes; typewriters and office requisites (except furniture); instructional and teaching material (except apparatus); plastic materials for packaging (not included in other classes); printers' type; printing blocks; jotters* in Class 16. An opposition was filed pursuant to Article 8(1)(b) EUTMR, that the opponent based on the earlier word marks **NANU-NANA**, registered for *paper and cardboard and goods made from these materials (included in Class 16), pamphlets, newspapers; periodicals; artists' materials, in particular paint boxes, paint brushes, crayons; pictures; decorative articles of paper and cardboard and toilet paper*, and **NANU**, registered for *paper and cardboard and goods made from these materials (included in Class 16), stationery, postcards, hinged cards, papier mâché, posters, calendars, pamphlets, newspapers; periodicals; artists' materials, in particular paint boxes, paintbrushes, crayons, pictures; decorative articles of paper and cardboard and toilet paper* in Class 16. The Opposition Division (OD) dismissed the opposition, so the opponent filed an appeal. The Board of Appeal (BoA) upheld the appeal, finding that the conflicting goods were identical or at least highly similar and that the signs had a low degree of visual similarity and an average degree of phonetic similarity. It also found that the earlier marks had an average distinctive character and concluded that there was a likelihood of confusion (LOC.) The applicant filed an action before the General Court (GC), relying on three pleas in law: (i) infringement of Article 8(1)(b) EUTMR, (ii) infringement of Article 1(1) EUTMR and the principle of autonomy and (iii) infringement of the principles of legal certainty, legality and good administration. **Relevant public.** LOC must be assessed by reference to the general public consisting of consumers with an average degree of attention in the territory of the European Union (para. 21). **Comparison of goods.** The *printers' type, printing blocks, typewriters, adhesives for stationery [and] plastic materials for packaging not included in other classes* applied for are not highly similar but simply similar, either to an average or to a low degree, to the earlier marks' goods (para. 53). As regards the comparison between the *artists' materials* of the earlier marks in Class 16 and the *printers' type; printing blocks; typewriters [and] adhesives for stationery or household purposes*, in point 54 of the GC's judgment of 19 June 2012, it states that some of the generic terms in the class headings of the Nice Classification are not clear and precise enough. *Artists' materials* belongs to this group of terms that are too vague to allow, without further information, to determine with certainty and on that basis alone, which goods are covered by this term (para. 58). According to point 60 of the abovementioned judgment, it is not for the court or the BoA to interpret vague and inaccurate terms such as *artists' supplies*, it is rather for the applicant to designate those goods with sufficient clarity and precision so as to inform the competent authorities and economic operators of the exact scope of protection intended for the mark (para. 59). The BoA's position that *artists' materials* includes all types of goods used by artists to produce works of art would amount to a finding of similarity with all sorts of very



different goods due to the diversity of artistic activity (para. 60). Therefore, if the applicant wanted to claim protection for artists’ supplies, it should have chosen wording for the list of goods that clearly indicated its intention; it cannot benefit from not fulfilling its obligation to indicate the list of goods in a clear and precise manner (para. 62). Unlike the case of the mark applied for, for the earlier marks, the goods *artists’ materials* have been the subject of a certain degree of specification; *artists’ materials, in particular paint boxes, paintbrushes, coloured pencils*, for the NANU-NANA mark, and *artists’ materials, in particular paint boxes, paintbrushes, pencils, pictures*, for the mark NANU. Although, according to the case-law, the term ‘in particular’ in a list of goods only has an exemplary meaning, clarifying what scope of protection the trade mark applicant wanted when it filed its application for registration (paras 63-65). Since the BoA did not consider the manner in which the earlier marks’ claim to *artists’ materials* was specified, it incorrectly found an identity with certain of the goods for which protection was sought, namely *printers’ type; printing blocks; typewriters [and] adhesives for stationery or household purposes* (paras 63-67). **Comparison of the signs.** Considering that the overwhelming majority of the relevant public will perceive the figurative mark applied for as consisting of the word element ‘nuuna’ (para. 81), a word comprising the same three letters as the earlier marks, ‘n’, ‘u’ and ‘a’, and also beginning with an ‘n’, there is a low visual and an average phonetic similarity between the mark applied for and the earlier marks (paras 84, 98) and there is no conceptual similarity as they have no meaning, even if the mark applied for could be perceived by some as a forename (para. 99).

♦[T-44/17](#); **CAMOMILLA / CAMOMILLA (fig.)**; *Camomilla Srl v EUIPO*; Judgment of 13 November 2018; EU:T:2018:775; Language of the case: IT



EUTM	Earlier trade mark
CAMOMILLA	

The EUTM proprietor registered the word mark **CAMOMILLA** as an EUTM for goods in, inter alia, Classes 18 and 25. An invalidity application was filed pursuant to Articles 59(1)(b) and 60(1)(a) EUTMR in conjunction with Article 8(1)(b) and Article 8(5) EUTMR, based on the earlier Italian figurative mark above, registered for Class 25 (*clothing and clothing accessories of all types*). The Cancellation Division (CD) dismissed the invalidity application, insofar as it found, inter alia, that the invalidity applicant had not adduced proof of use of the earlier mark and there was no likelihood of confusion (LOC). The invalidity applicant filed an appeal. The Board of Appeal (BoA) dismissed the appeal, finding, inter alia, that the use of the earlier mark was not sufficiently proven, and that certain documents were inadmissible as submitted for the first time before the BoA. The invalidity applicant filed an action before the General Court (GC), which the GC upheld, considering the belated evidence to be admissible as complementary. After remittal, the BoA re-examined the appeal and partially upheld it, insofar as it found that the earlier mark had previously been used in Italy for goods in Class 25 and that there was LOC for goods in Classes 18 and 25. The EUTM proprietor filed an action before the GC, relying on four pleas in law: (i) infringement of Article 94 EUTMR, (ii) infringement of Article 95(1) EUTMR, (iii) infringement of Article 60(1)(a) EUTMR in conjunction with Article 8(1)(b) EUTMR, and (iv) infringement of Article 64(3) EUTMR in conjunction with Article 64(2) EUTMR. **Dominant element.** The trade mark appears in forms that include the dominant word element ‘CAMOMILLA’, accompanied by other descriptive figurative and word elements



such as ‘Italia’ and ‘Moda donna’ (paras 47-48). **Relevant public.** The relevant public is the Italian public with an average level of attention (paras 85-86). **Comparison of the goods.** The goods in Class 25 are either identical (*footwear*) or similar due to complementarity, especially from an aesthetic perspective, and since they also share the same distribution channels, target the same public and are normally manufactured by the same undertakings (paras 90-91). The contested goods in Class 18 (*rucksacks, key cases, etc.*) are also slightly similar to items of clothing, since they usually share the same manufacturers, distribution channels and end consumers (para. 92). **Comparison of the signs.** (i) There is a certain degree of visual similarity between the signs: the respective stylisations are similar and devoid of any fanciful elements, whereas the dominant element ‘CAMOMILLA’, which will attract most of the public’s attention, counteracts the differences arising from the presence of certain figurative elements in the earlier trade mark. (ii) They are phonetically identical, given that their only word element, ‘CAMOMILLA’, will be pronounced in the same way. (iii) The signs are also identical from a conceptual perspective, since they both allude to the concept of ‘camomile’, which is widely understood to be a variety of annual herbaceous plant of the Asteraceae family (para. 98). **LOC.** Given the level of attention of the relevant public, the identity or similarity of the goods and the high degree of similarity of the signs and also taking the normal distinctive character of the earlier mark into account, there is LOC (paras 104-105).

**T-486/17; DIETOX (fig.) / Diator (fig.); Foodterapia, SL v EUIPO;** Judgment of 14 November 2018; EU:T:2018:778; Language of the case: EN

EUTM application	Earlier trade mark
	

The applicant sought to register the figurative mark above as an EUTM for goods and services in Classes 3, 5, 29, 30 and 43. An opposition based on the earlier EU figurative mark above, registered for goods in Classes 5, 29 and 30, was filed pursuant to Article 8(1)(b) EUTMR. The Opposition Division (OD) rejected the opposition, so the opponent filed an appeal. The Board of Appeal (BoA) upheld the opposition. The applicant went on to bring an action before the General Court (GC), relying on a single plea in law: infringement of Article 8(1)(b) EUTMR. **Relevant public.** The relevant public consists of the general public with regard to all of the goods, and of professionals with regard to certain goods. However, it is the section of the public with the lowest level of attention that has to be taken into account for the purposes of assessing the likelihood of confusion (para. 26). The level of attention is lower than average for goods that might be bought spontaneously, average for most of the goods covered, and higher for the consumer health goods in Class 5 (para. 28). **Comparison of the goods.** The goods covered are identical (para. 33). **Comparison of the signs.** (i) The signs have the sequence of letters ‘dieto’ in common, positioned in the same order. The weak distinctiveness of the stem ‘diet’ does not mean, however, that it should be neglected in the visual analysis of the signs (para. 66). The signs differ clearly in their figurative elements, their design and the last letter of their word elements (‘diator’ for the earlier mark and ‘dietox’ for the contested mark) (para. 67). The fact that the word element of the earlier mark is its dominant element reinforces both the



similarities and the differences between the signs (para. 68). Since the figurative element of the contested mark reproduces or announces the stylised letter of its word element and also makes up the grey background on which the word element is written, the relevant public will remain focused on that word element. In addition, reading that word element reveals its similarity to the word element of the earlier mark (para. 69). (ii) The signs are phonetically very similar: no matter how they are pronounced, the letters common to the word element in each of the signs, ‘d’, ‘i’, ‘e’, ‘t’ and ‘o’, will always be pronounced in the same way. Moreover, the last syllables of the words are almost identical, being based on the same vowel ‘o’. They also have the same rhythm, sound and intonation because of their almost identical structure (para. 74). (iii) The words ‘dietor’ and ‘dietox’ have no known meaning as such (para. 82). However, the common stem ‘diet’ alludes to the concept of diet or dietetic foodstuffs. Therefore, both words ‘dietor’ and ‘dietox’, whether they are written or pronounced, allude to the word ‘diet’ in some way, that is to say, to a particular diet (para. 83). Finally, the figurative elements of the signs at issue have no definite meaning (para. 84) and are similar overall (para. 86). **LOC.** The goods covered by both marks are identical, and the signs have some visual and conceptual similarity and a high degree of phonetic similarity (para. 91). Consequently, there is LOC (para. 93). **Scope of proceedings.** The Office’s guidelines are a self-imposed restriction, which cannot go against the interpretation that the EU Courts have given to a legal rule (para. 96).

**T-36/18; Celeson / CELESIO; Asahi Intecc Co., Ltd v EUIPO;** Judgment of 20 November 2018; EU:T:2018:808; Language of the case: EN. The applicant designated the European Union for international registration No 1 254 798 for the word mark **Celeson** for goods in Class 10. An opposition was filed pursuant to Article 8(1)(b) EUTMR, based on the international registration of the earlier word mark **CELESIO**, registered, inter alia, for goods in Class 10. The Opposition Division (OD) upheld the opposition for the goods in question. The applicant filed an appeal against the OD’s decision. The Board of Appeal (BoA) dismissed the appeal as it found, taking into account the attentiveness of the relevant public, that there was a likelihood of confusion (LOC) due to the identity between the goods, the high degree of visual and phonetic similarity between the earlier mark and the mark applied for, and the normal degree of distinctiveness of the earlier mark. The applicant filed an action with the General Court (GC), relying on a single plea in law: infringement of Article 8(1)(b) EUTMR. **Relevant public.** The relevant public to be taken into consideration consisted of specialists, in the European Union, in ‘the medical and surgical field with specific professional knowledge in the medical field’ and with a high level of attention. This was not disputed by the parties (paras 37 and 38). **Comparison of the goods.** The BoA considered that the contested *surgical, medical and dental apparatus and instruments, and their parts and accessories* were identical to the opponent’s *surgical, medical and dental apparatus and instruments* (para. 41). The BoA considered that the other goods covered by the mark applied for were all medical apparatus and instruments for the catheter treatment of coronary artery diseases and were, therefore, part of the broad category *medical apparatus and instruments* of the earlier mark. The term *medical apparatus and instruments* was clear and precise, and the applicant itself had used it in its lists (para. 42). By the first part of its plea, the applicant submitted that use of a general indication could not suffice to show that goods were similar (para. 44). In that respect, the BoA found that the general indication *medical apparatus and instruments* of the opponent’s goods in Class 10 was sufficiently clear and precise to determine the scope of the trade mark protection to be afforded (para. 47). As rightly pointed out by the BoA, the meaning of ‘medical device’ was defined by Council Directive 93/42/EEC as ‘any tool or device used to prevent, diagnose or treat a disease or illness’ (para. 51). Therefore, the general indication *medical apparatus and instruments* that features on the list of the opponent’s goods is all the more sufficiently clear and precise in that, as correctly observed by the BoA, the applicant itself had used it





in its own list of goods (para. 53). It followed that the applicant's argument that this general indication was vague and imprecise could not validly succeed (para. 54). Since case-law considers goods to be identical when the goods for which protection is sought are included in a more general category covered by the early mark, and since the BoA rightly found that the general category of *medical apparatus and instruments* included the goods covered by the mark applied for, it was also correct in concluding that the *medical apparatus and instruments* covered by the earlier mark were identical to all the other goods covered by the mark applied for (paras 56 and 57). By the second part of its plea, the applicant submitted that the BoA was wrong in finding that *stents and their parts and accessories* fell within the category *medical apparatus and instruments* (para. 59). However, by referring to the usual meaning of the term 'stents', and to their nature, intended purpose and method of use, the BoA rightly found that the term formed part of the broader category of *medical apparatus and instruments* covered by the earlier mark (para. 65). Therefore, the BoA rightly held that the *medical apparatus and instruments* covered by the earlier mark were identical to the *stents and their parts and accessories* covered by the mark applied for (para. 66). It follows that the BoA did not err in considering that the goods were identical (para. 67).

**Comparison of the signs. Visual similarity.** Assessment of the visual, phonetic and conceptual similarity has to be based on the overall impression given by the signs (para. 68). By the third part of its plea, the applicant submitted that the BoA had been wrong in finding the marks visually similar to a high degree, as the two signs differed in their suffixes 'io' and 'on' which had a strong influence on the visual characteristics of the signs (para. 72). The overall impression showed that each of the signs shared the same sequence of letters 'c-e-l-e-s\*-o-\*', the first five of which were identical and appeared in the same order (para. 75). The initial part of the two signs coincided in that they were made up of five identical letters of the seven letters in total (para. 76). Even if their respective suffixes 'io' and 'on' were different, they shared the letter 'o', with the result that the only difference lay in the penultimate letter 'i' of the earlier mark and the last letter 'n' of the sign applied for, which was a difference of secondary importance. The signs were therefore visually highly similar (paras 78-80).

**Phonetic similarity.** By the fourth part of its plea, the applicant submitted that the BoA was wrong in finding the signs phonetically similar without having taken into account the overall sonority (para. 82). The two signs consisted exclusively of verbal elements. As the words were devoid of conceptual meaning, the relevant consumer was likely to pronounce the words in accordance with the pronunciation rules of his or her language, so the two words could have the same rhythm and intonation, and produce a similar overall phonetic impression (para. 85). The overall phonetic impression was dominated, in each of the signs, by the fact that their pronunciations coincided as regards the sound of the letters 'c-e-l-e-s'. Therefore, it had to be found that those signs were highly similar phonetically (paras 86-87). Even if their respective suffixes 'io' and 'on' were different, they did not create a significant difference in the sound resulting from the pronunciation of the signs. The BoA concluded that the marks were highly similar phonetically (paras 88-90).

**Conceptual similarity.** The BoA considered that neither of the signs had any meaning for the relevant public (paras 91 and 92).

**LOC.** By the fifth part of its plea, the applicant submitted that the BoA had wrongly assessed the relevant factors for finding a LOC (para. 94). The BoA was right in considering that, in spite of the high level of attentiveness of the relevant public, there was a LOC between the marks as the signs were similar overall to a high degree both visually and phonetically (paras 101 and 107).

♦[T-724/17](#); **VIANEL/VIANIA et al.**; *The Vianel Group LLC v EUIPO*; Judgment of 22 November 2018; EU:T:2018:825; Language of the case: EN. An opposition based, inter alia, on the EUTM registration for the word mark **VIANIA** was brought against the international registration (IR) designating the EU for the word mark **VIANEL**, pursuant to Article 8(1)(b) EUTMR. The Opposition Division (OD) partially upheld the opposition,



namely, for *clothing, namely, sweaters, t-shirts, shirts, blouses, corsets, suits, vests, raincoats, skirts, coats, trousers, pullovers, dresses, jackets, shawls, sashes for wear, scarves, neckties, pocket squares, suspenders, gloves, belts, stockings, tights, socks, singlets, bathing suits and bath robes* in Class 25. It found that genuine use of the earlier mark was proved only for *underwear* in Class 25, and that there was a likelihood of confusion with the contested IR for the abovementioned goods in Class 25. The Board of Appeal (BoA) dismissed the appeal filed by the IR holder. It noted that the IR holder had accepted the OD's findings on genuine use of the earlier mark and the identity and similarity of the goods. The BoA thus endorsed the OD's reasoning both in this respect and regarding the likelihood of confusion. The IR holder brought an action before the General Court (GC), relying on two pleas in law: (i) irrelevance of the evidence of genuine use submitted by the opponent before the OD and (ii) infringement of Article 8(1)(b) EUTMR. **Likelihood of confusion.** Visually, neither the difference between the last two letters of the signs at issue, nor the repetition of the group of letters 'ia' in the earlier mark, can counteract the visual similarity resulting from the signs being of the same length and coinciding in their first four letters (paras 34-37). Phonetically, the homophony of the sounds produced by the repeated vowels 'ia' is not in itself sufficient to counteract all phonetic similarity between the signs, due to the presence of the common group of letters 'vian', so that the marks are phonetically similar to an average degree (paras 39-40). Conceptually, the signs are dissimilar as the earlier mark has no meaning while the contested IR 'VIANEL' might be perceived in France as a family name (para. 41). As the signs are similar overall to an average degree and the goods are partly identical and partly similar, the BoA correctly concluded that there was a likelihood of confusion between the signs in relation to the abovementioned goods in Class 25 (para. 45).

**T-59/18; FEMIVIA / FEMIBION INTIMA et al.; Endoceutics, Inc. v EUIPO;** Judgment of 22 November 2018; EU:T:2018:821; Language of the case: EN. The applicant sought to register the word mark **FEMIVIA** as an EUTM for *pharmaceutical preparations for the prevention and treatment of breast and uterine cancer, Alzheimer's disease, medical conditions related to menopause, bone loss, muscle loss, type 2 diabetes, fat accumulation, osteoporosis, hot flushes, skin atrophy, memory loss, and cognition loss* in Class 5. An opposition based on the earlier EU word mark **FEMIBION INTIMA** registered for, inter alia, *pharmaceutical preparations* in Class 5 was filed pursuant to Article 8(1)(b) EUTMR. The Opposition Division (OD) upheld the opposition. The applicant filed an appeal. The Board of Appeal (BoA) dismissed the appeal finding that for the identical goods there would be a LOC on the part of the Spanish-speaking public, as the signs had an average degree of visual and phonetical similarity, and a certain degree of conceptual similarity. In particular, the prefix 'fem', common to the signs at issue, would be understood by the Spanish-speaking public as being an abbreviation of the Spanish word 'femenino', which describes the intended purpose for the goods. Despite its weak distinctive character, such a prefix should not be neglected in the comparison. As regards the element 'intima', its distinctive character for the opponent's goods was weak or even non-existent. The applicant filed an action before the General Court (GC), relying on one single plea in law: infringement of Article 8(1)(b) EUTMR. **Relevant public.** It is not disputed that the relevant public consists of both the average consumer and professionals in the medical and pharmaceutical sectors of the EU and that this public will have a high level of attention. For reasons of procedural economy, the Court focuses the comparison on the Spanish-speaking public of the EU, as did the OD and the BoA (paras 22-24). **Comparison of the goods.** It is not disputed that the goods are identical (paras 25-26). **Distinctive elements of the signs.** Although the common element 'fem' will be understood by the Spanish public as referring to the word 'femenino' (meaning 'feminine'), which is descriptive of the purpose of some of the goods, it is still likely to attract the attention of the public, in particular, because of its position at the





beginning of the mark (para. 34). The element ‘intima’ of the earlier mark, which would probably be perceived by Spanish consumers as an indication of the intimate or personal use of the goods concerned, or as a reference to their purpose, albeit a weak element, cannot be classed as negligible (paras 39-41). The element ‘femibion’ would be perceived as the most distinctive element in the earlier mark (para. 42). **Comparison of the signs.** The signs are visually similar at least to a low degree as ‘femibion’, which is the most distinctive element of the earlier mark, and the mark applied for, ‘**FEMIVIA**’, coincide in their first four letters and are thus similar to an average degree (paras 46-48). The signs are phonetically similar to an average degree as the elements ‘femivia’ and ‘femibion’ have a high degree of similarity, in particular due to the pronunciation of the letter ‘v’ as a ‘b’ in Spanish and considering that the element ‘intima’ of the earlier mark is weakly distinctive (paras 50, 52, 54). Taken as a whole, the signs are conceptually similar at least to a low degree insofar as the common prefix ‘fem’ evokes the Spanish word ‘femenino’ (paras 53-56). **Likelihood of confusion.** As the goods are identical and the signs have at least a low degree of similarity visually and conceptually, and an average degree of similarity phonetically, in the light of the distinctive elements of the signs at issue, and despite a high level of attention of the relevant public, there is LOC in the mind of at least a part of the relevant public (para. 59) since the principle of interdependence between the factors needs to be taken into account for the assessment (para. 63).

**T-826/17; FYYO / FIO et.al.; TeamBank AG Nürnberg v EUIPO**; Judgment of 22 November 2018; EU:T:2018:819; Language of the case: DE. The applicant sought to register the word mark **FYYO** as an EUTM for goods and services in Classes 9 and 38, inter alia. An opposition based on the earlier word mark **FIO**, registered for goods and services in Classes 9 and 38, inter alia, was filed pursuant to Article 8(1)(b) EUTMR. The Opposition Division (OD) dismissed the opposition. The opponent filed an appeal. The Board of Appeal (BoA) upheld the appeal. It found that there was LOC, considering that the goods and services were identical and that the signs were similar, or even identical, from a phonetic point of view, and had a lower than average level of visual similarity, whereas from a conceptual point of view the comparison was neutral. The applicant filed an action before the General Court (GC), relying on one sole plea in law: infringement of Article 8(1)(b) EUTMR. It is not disputed that the relevant public consists of the English-speaking final consumers of the EU, whose degree of attention is average; that the goods and services are identical; and that the earlier mark has an average distinctive character (para. 19). It is also undisputed that the signs are phonetically very similar or even identical and that the similarity is conceptually neutral (para. 20). **Visual similarity of the signs.** The structure of the marks is the same, as they both consist of a single word element (para. 27). In addition, two of the letters in the signs are identical and placed in the same order, namely the letter ‘f’, by which the signs begin, and the letter ‘o’, by which they end. Therefore, the differences between the signs are limited to their central parts, namely ‘yy’ on the one hand, and ‘i’ on the other (paras 29-30). However, even if the letters ‘y’ of the mark applied for attract attention, insofar as this is an unusual combination of letters, this feature does not, on its own, exclude any similarity between the two signs (para. 30). Although the difference concerning their central parts prevents the signs from being regarded as having a high degree of visual similarity, it does not in any way preclude that they are considered similar to a lower than average degree (para. 33). The fact that, for the goods and services at issue, the visual perception plays a decisive role in the overall assessment of LOC, because it may be considered that they are mainly purchased and used online (in particular, *computer software* and *providing access to platforms and portals on the internet*), this does not call into question the finding of LOC. First, because the signs are visually similar, albeit to a lower than average degree; second, because it cannot be ruled out that in certain cases the goods and services are offered aurally, on the radio or by other



consumers; and third, because for the identical goods and services, the differences between the signs are not capable of counteracting the similarities between them (paras 42-43). There is LOC and the appeal must be rejected (para. 44).

♦[T-817/16](#); **OV (fig.) / V (fig.)**; *Vans, Inc. v EUIPO*; Judgment of 6 December 2018; EU:T:2018:880; Language of the case: DE

EUTM application	Earlier trade mark
	

The applicant sought to register the figurative mark ‘V’ as an EUTM for goods and services in Classes 18 and 25. An opposition based on the earlier figurative mark ‘V’, registered for goods and services in Classes 18 and 25, was filed pursuant to Article 8(1)(b) EUTMR. The existence of the earlier mark being an international registration was shown by an excerpt from the EUIPO’s TMview database. The Opposition Division (OD) partially upheld the opposition. The applicant appealed and, in its observations, the opponent filed a cross-appeal. The Board of Appeal (BoA) dismissed the appeal in its entirety and upheld the cross-appeal partially. The applicant filed an action before the General Court (GC), relying on three pleas in law: (i) infringement of Article 7(2) and (4) and Article 8(1) and (7) EUTMDR, (ii) infringement of Article 8(1)(b) EUTMR and (iii) infringement of Article 68(1), first sentence, Article 70(2) and Article 94(1) EUTMR and of the principle of prohibition of *reformatio in peius* and of the right to be heard. **Likelihood of confusion. Relevant public.** The goods in Classes 18 and 25, including *footwear* and *backpacks*, even if not purchased on a daily basis, are, in principle, common consumer goods intended for the general public. The level of attention of consumers is therefore average (para. 65). **Comparison of the goods.** The goods for which protection is sought, *gloves* and *belts*, are at least very similar to the earlier mark’s *clothing*, also in Class 25, as they must be regarded as clothing products intended to cover and protect the human body. They also fulfil an aesthetic function and are often marketed in the same outlets as clothing (paras 75-76). The *key rings* applied for in Class 18, in addition to the function of making it easy to find keys, can also have a decorative function; they are thus at least very similar to the opponent’s *small leather goods* (paras 83-85). **Comparison of the signs.** The signs must be compared as respectively registered, that is, in black and white and not as they might have been used in the marketplace (para. 95). The signs coincide in the representation of a ‘V’-shaped element within a circle of a comparable diameter and they both include a horizontal bar pointing to the right. These common elements prevail over their minor dissimilarities and, therefore, the BoA rightly held that the signs are visually similar to an average degree (paras 99-102). Part of the relevant public will recognise the letter ‘V’ in the signs and will therefore pronounce the signs identically, so the signs were rightly held to be phonetically identical (paras 105-106). The element ‘V’, a letter of the alphabet, has no semantic meaning and therefore no conceptual comparison between the signs is possible (para. 107). **Distinctiveness of the earlier mark.** The earlier mark’s distinctive character was rightly held to be average, as the sign consists not only of the ‘V’ element, but also of additional figurative elements (para. 118) and is not descriptive of the goods (para. 119). **Likelihood of confusion.** Considering the average distinctiveness of the earlier mark, the identity or strong similarity of the goods, and the fact that the signs are visually similar and, insofar as they are pronounced, phonetically identical, the BoA rightly held that there is LOC for the relevant public, that is to say, the average consumer in the EU (para. 127).



**T-115/18; KINDERPRAMS / Kinder (fig.) et al.; Tomasz Kawałko Trofeum v EUIPO;** Judgment of 6 December 2018; EU:T:2018:882; Language of the case: EN

EUTM application	Earlier trade marks
KINDERPRAMS	

The applicant sought to register the word mark **KINDERPRAMS** as an EUTM for services in Classes 35 and 38. An opposition based on the earlier Italian figurative marks above, registered for, inter alia, Classes 35 and 38, was filed pursuant to Article 8(1)(b) EUTMR. The Opposition Division (OD) partly upheld the opposition with the exception of the services *business brokerage* and *wholesaling and retailing vehicle safety seats for children* in Class 35. The applicant appealed and the Board of Appeal (BoA) annulled the OD's decision insofar as it had upheld the opposition for *auctioneering* services in Class 35, since those services differed from the opponent's goods and services. It found likelihood of confusion (LOC) regarding all the other identical or similar services. The applicant filed an action before the General Court (GC), relying on a single plea in law: infringement of Article 8(1)(b) EUTMR. **Relevant public.** The relevant territory was Italy and the relevant public included the public at large and the professional public, with an average to above average level of attention (paras 25-26). **Comparison of the services.** (i) The opponent's *advertising services* in Class 35, include the contested mark's *marketing and presentation of goods*, etc., and were, therefore, considered identical (para. 30). The contested mark's *import-export agency services* and *accepting orders for goods via means of telecommunication*, were similar, at least to an average degree, to the opponent's *business administration* services, which are provided by specialised companies who study their clients' needs and provide all the necessary information and advice in order to help them with the organisation and running of their businesses. These services all served the same purpose, targeted the same professional clients and could be provided by the same service providers (para. 31). (ii) The goods that were the subject of the contested mark's services were identical to the opponent's goods. They could be offered in the same places as those in which the opponent's goods were sold. Furthermore, there was a complementary nature between the contested mark's services and the opponent's goods (para. 32). There was a



strong link between certain services designated by the contested mark and certain goods designated by the earlier mark in the sense that the services consisted of the sale of those goods, which were, therefore, complementary (para. 34). (iii) The BoA found that the contested mark's services in Class 38, that is, *news agencies; radio and television broadcasting, communications and data transmission via the internet, computer networks and other means of communication, electronic mail, electronic mail accounts* belonged to the broader category of the opponent's *telecommunication services* in Class 38. Furthermore, the contested mark's services *providing user access to information on computer networks, setting up and providing computer services relating to discussion lists and forums; electronic advertising* were similar to the opponent's *telecommunication services* in Class 38, since those types of services were provided by the same undertakings and intended for the same users (para. 39). **Comparison of the signs.** (i) The signs were found to be visually similar to an average degree, given that the element 'kinder', the sole component of the earlier mark, is included in its entirety within the contested mark, making the marks partly identical (paras 48, 52). The fact that several undertakings use the word 'kinder' to designate their goods does not preclude that the relevant public, when encountering a sign, will pay more attention to the first part thereof (para. 51). (ii) The signs were found to be phonetically similar to an average degree due to the presence of the same series of letters in both signs, which are placed at the beginning of the signs and, therefore, more likely to attract the consumer's attention (para. 56). (iii) The applicant failed to prove that the two word elements were part of basic German and English vocabulary and would, on that basis, be understood by the Italian public. Furthermore, the GC had already ruled that, for the public at large in Italy, the word 'kinder' had no meaning, and therefore, the marks would not convey any concept for the relevant public (para. 60). **LOC.** In light of the identical nature of some of the services, the similarities between the other goods and services covered by the marks, the visual and phonetic similarities between the signs, the average level of distinctiveness of the earlier mark, and notwithstanding the average to above average level of attention of the relevant public, there is LOC (para. 67).

♦[T-665/17](#); **CCB (fig.) / CB (fig.) et al.**; *China Construction Bank Corp. v EUIPO*; Judgment of 6 December 2018; EU:T:2018:879; Language of the case: EN

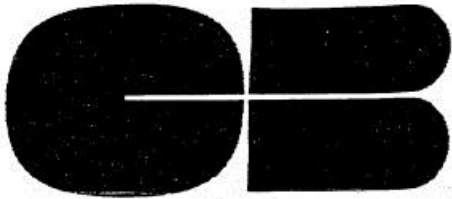
EUTM application	Earlier trade mark
	

The applicant sought to register the figurative mark above as an EUTM for services in Class 36. An opposition based on the earlier EU figurative mark above registered for services in Class 36 was filed pursuant to Article 8(1)(b) EUTMR. The Opposition Division (OD) upheld the opposition, as it found likelihood of confusion (LOC). The applicant filed an appeal, which was dismissed by the Board of Appeal (BoA). The applicant filed an action with the General Court (GC) relying on two pleas in law: (i) infringement of Article 94(1) and Article 95(1) EUTMR, and (ii) infringement of Article 8(1)(b) EUTMR. **Relevant public.** The relevant public consists of professionals and the general public, with a high level of



attention (para. 35). **Enhanced distinctiveness.** For the purposes of assessing whether the earlier mark had enhanced distinctiveness, the BoA properly relied on the elements put forward to establish its reputation (para. 41). The BoA was not obliged to assess whether the earlier mark had enhanced distinctiveness for all of the services it covered in Class 36. The BoA therefore correctly examined the reputation of the earlier mark in relation to *financial affairs, monetary affairs and banking* (para. 45). The BoA's assessment of the earlier mark's distinctiveness was correct (para. 48). **Comparison of signs.** The BoA was able, without erring in law, to rely on the reputation of the earlier mark in France and, therefore, to rely on the significance of the awareness of the link that mark establishes with the bank cards of the Groupement des cartes bancaires, described by the acronym CB, in order to correctly deduce that the relevant public will perceive the earlier mark as being the word element consisting of the acronym 'CB' (para. 54). The BoA acted correctly in relying mainly on the word element 'cb' of the earlier mark when comparing the signs (para. 58). The visual similarity between the signs due to both including the uppercase letters 'CB' is not offset by the differences resulting from the additional uppercase letter 'C' in the contested mark and the different figurative elements of the two signs (para. 61). There is a high degree of phonetic similarity, as the distinctive elements of the signs ('CCB' and 'CB') are pronounced letter by letter in a very similar manner, with the only difference being the repetition of the letter 'c' in the contested mark (para. 62). It is not possible to make a conceptual comparison (para. 63). **LOC.** Given the identity of the services concerned, the reputation of the earlier mark in France, and the similarity of the signs, there is LOC (para. 67). Even if the BoA erred in finding there was no regular use of the services covered and wrongly took that into account, that finding merely corroborates, as a supplementary ground, the general consideration that the relevant public retains an imperfect image of the trade marks, a matter not disputed by the applicant (para. 68).

♦ [T-378/17](#); **CERVISIA / CERVISIA AMBAR**; *La Zaragozana, SA v EUIPO*; Judgment of 7 December 2018; EU:T:2018:888; Language of the case: EN

EUTM application	Earlier trade mark
	<p style="text-align: center;"><b>CERVISIA AMBAR</b></p>

The applicant sought to register the figurative mark above as an EUTM for goods in Classes 32 and 33. An opposition based on the earlier Spanish word mark **CERVISIA AMBAR**, registered for *beer* in Class 32, was filed pursuant to Article 8(1)(b) EUTMR. The Opposition Division (OD) upheld the opposition, since it found likelihood of confusion (LOC). The opponent filed an appeal and the Board of Appeal (BoA) upheld the appeal. It found that, even though the signs were aurally similar to a low degree; that similarity was outweighed by the visual and conceptual differences. Therefore, considering that the figurative elements of the mark applied for are meaningful and that the common element of the marks at issue was of weak distinctive character, there was no LOC. The opponent filed



an action before the General Court (GC) relying on a single plea in law: infringement of Article 8(1)(b) EUTMR. **Relevant public.** The relevant public is the general public in Spain, who will display a normal level of attention (para. 19). **Comparison of goods.** The opponent’s *beers* are identical to the contested mark’s *beers; lagers; wheat beer; malt beer*, highly similar to *non-alcoholic beer*, averagely similar to *mineral and aerated waters and other non-alcoholic drinks; fruits beverages and fruit juices; syrups and other preparations for making beverages* and similar to the *alcoholic beverages (except beers)* (para. 20). **Comparison of signs.** It cannot be concluded that the word element of the contested mark is ‘barely legible’ and, consequently, it cannot be presumed that the relevant public will easily recognise the whole word based on what is visible (para. 24). Due to the common word element ‘cervisia’, the signs are visually similar to a certain degree, which must be qualified as average (para. 27). The strong stylisation of the contested mark cannot ‘outweigh’ that similarity (para. 28). The average consumer will easily realise that the word element of the contested mark is ‘cervisia’ and not ‘visia’. Since the consumer will pronounce the word ‘cervisia’ as a whole, the signs have a certain degree of aural similarity which may also be categorised as average (para. 30). In the absence of relevant evidence regarding the perception of the word ‘cervisia’ by the relevant public, the BoA was not entitled to consider whether the relevant public had such a knowledge of Latin that it could ‘easily link’ the word ‘cervisia’ to the word ‘cerveza’, whose pronunciations differ in Spanish, or to the concept of beers. It was for the BoA to produce such evidence, given that the perception of the word ‘cervisia’ by that public could not be regarded as a well-known fact (para. 35). Given the presence of the word ‘cervisia’, which has no particular meaning for the relevant public and, firstly, the word ‘ambar’ which means ‘amber’ and, secondly, the representation of a seahorse, the signs should be regarded as conceptually different (para. 36). The general public in Spain, will not be able to connect a Latin word — which the BoA itself pointed out was not a Spanish word and was not commonly used — to the Spanish word corresponding to the reading of the cited Latin dictionary (para. 48). The word element ‘cervisia’ does not have a weak distinctive character, but rather a normal degree of inherent distinctive character (para. 49). Given, in particular, the average degree of visual and aural similarity between the marks, there is LOC (para. 52).

**T-821/17; VITROMED Germany (fig.) / Vitromed; Vitromed GmbH v EUIPO;** Judgment of 12 December 2018; EU:T:2018:912; Language of the case: DE

EUTM application	Earlier trade mark
	<p data-bbox="1007 1536 1129 1570">Vitromed</p>



The applicant sought to register the figurative mark above as an EUTM for goods in Classes 5 and 10. An opposition based on the earlier European Union word mark **Vitromed**, registered for goods in Class 10, was filed pursuant to Article 8(1)(b) EUTMR. The Opposition Division (OD) upheld the opposition, and the applicant filed an appeal. The Board of Appeal (BoA) dismissed the appeal insofar as it found that there was likelihood of confusion (LOC) for the relevant English-speaking professional public in the EU. The applicant filed an action before the General Court (GC), relying on a single plea in law: infringement of Article 8(1)(b) EUTMR. **Relevant public.** The relevant public is to be determined on the basis of the goods as registered (para. 29). It consists of a specialised public within the EU with specific professional knowledge or expertise, such as specialists in the medical field (paras 30-31). **Comparison of the goods and services.** There is





identity between the contested Class 10 goods and the Class 10 goods of the earlier mark, since the former are included in the latter (paras 37-42). The contested biological preparations and tissue cultures in Class 5 are similar to the Class 10 goods of the earlier mark: they relate to the medical field and are intended for medical use. In addition, they may be complementary. They may also be aimed at the same specialist, and have the same origin and distribution channels (paras 43-49). **Distinctive and dominant element.** The element 'VITROMED' is the most important element in the overall impression of the contested sign. However, the smaller figurative element at the beginning of the contested mark is not negligible, unlike the small, non-distinctive word element 'Germany' underneath the word 'VITROMED' (para. 69). **Comparison of the signs.** (i) The signs are visually similar to a high degree. They coincide in 'VITROMED', which is the only component of the earlier trade mark. Although the figurative element of the contested sign is not negligible, it will not be able to divert the public's attention away from the word element (paras 73-74). (ii) Phonetically, the pronunciation of the signs coincides in the sound of the letters 'VITROMED', present identically in both signs. Given its size, position and lack of distinctiveness, the word element 'Germany' will be negligible in the contested mark (para. 80). The figurative element of the contested sign will have little or no impact phonetically (para. 81). (iii) The signs are conceptually similar to a high degree, since it is likely that the relevant public will associate the common term 'VITROMED' with the meaningful words 'in vitro' and 'medical' (para. 84). **Distinctiveness of the earlier mark.** The inherent distinctiveness of the earlier mark is weak (para. 87). **LOC.** Due to the identity/similarity of the goods, and the high visual and conceptual similarity and phonetic identity of the signs, and despite the high level of attention of the relevant public and the weak distinctiveness of the earlier mark, there is LOC (paras 94, 96).

**T-46/17; Pet Cuisine (fig.) / THE PET CUISINE alimento para mascotas felices GENIAL (fig.) et al.; TDH Group v EUIPO;** Judgment of 14 December 2018; EU:T:2018:976; Language of the case: EN

IR designating the EU	Earlier trade mark
	

The applicant applied for international registration of the figurative mark above designating the EU for goods in Class 31. An opposition based on, inter alia, the earlier EU figurative mark above registered for goods in Class 31, was filed pursuant to Article 8(1)(b) EUTMR. The Opposition Division (OD) partially upheld the opposition for the following goods in Class 31: *seeds and agricultural products, not included in other classes; seeds, natural plants; foodstuff for animals, malt*, since it found likelihood of confusion (LOC). The applicant filed an appeal and the Board of Appeal (BoA) dismissed the appeal, confirming LOC. The applicant filed an action before the General Court (GC) relying on a single plea in law: infringement of Article 8(1)(b) EUTMR. **Relevant public.** The relevant public is composed of EU pet owners with an average level of attention (paras 41, 43). BoA



confirmed OD's assessment and in doing so it gave a sufficient statement of reasons for the contested decision (para. 46). Since it is not proved that the contested goods are similar, complementary or in competition with medical or veterinary products, it cannot be demonstrated that the relevant public displays a high level of attention on account of the impact, if any, of animal foodstuffs on the health of pets (paras 48-49). The BoA found that likelihood of confusion (LOC) exists even in situations in which consumers pay 'considerable attention' to the goods (para. 52). **Comparison of the goods.** *Foodstuffs for animals and seeds, agricultural products, not included in other classes and natural plants* are identical, whereas *foodstuffs for animals* and *malt* are similar: malt is frequently added to pet foods in order to increase its protein content, and, moreover, malt and foodstuffs for animals share the same distribution channels and are sold in the same outlets (paras 62-63). **Comparison of the signs. Distinctive and dominant elements of the marks.** The term 'pet cuisine' is more distinctive than the other figurative elements of the sign covered by the IR which are directly descriptive, since 'pet cuisine' alludes to the nature and purpose of the goods not only for the part of the relevant public that understands English while it remains fanciful for the non-English-speaking part of the relevant public (paras 84, 86). For the Spanish-speaking part of the relevant public, the word 'genial' is a laudatory term, lacking distinctiveness (para. 88) and the expression 'alimento para mascotas felices' means 'food for happy pets'. It has a weak distinctiveness, and is descriptive of the nature and intended purpose of the goods covered (para. 89). Therefore, at least for the Spanish-speaking part of the relevant public, the term 'pet cuisine' is the most distinctive element of the earlier mark, even if the meaning of that term is understood (paras 91, 98). 'Pet cuisine' is also the most dominant element of the marks because of its central position and because of its size in relation to the other elements (para. 102). **Visual similarity.** Despite the visual differences in the word and figurative elements and in their colour, the signs are mostly visually similar due to the common, dominant and distinctive element 'pet cuisine', at least for the Spanish-speaking public (para. 108). **Phonetic similarity.** The expression 'alimento para mascotas felices' in the earlier mark will not be pronounced; as it is significantly smaller and set apart beneath the term 'pet cuisine' (paras 117, 121). The marks have an average degree of phonetic similarity for the part of the relevant public that will pronounce the earlier mark by using the expression 'pet cuisine genial' and a high degree of phonetic similarity for the part of the relevant public that will pronounce that mark by using the term 'pet cuisine' (para. 126). **Conceptual comparison.** For that part of the relevant public that understands the term 'pet cuisine', the marks are conceptually similar and, for that part of the relevant public that does not understand the word elements of the marks, those marks are conceptually different (para. 141) **LOC.** BoA did not err in finding LOC (para. 153). Notwithstanding the conceptual difference for that part of the relevant public that does not understand the word elements of those marks, the average degree of visual and phonetic similarity, first, and the identity or similarity of the goods, second, are sufficient to establish LOC (para. 147). As the covered goods are sold, inter alia, in self-service stores, where the visual aspect takes precedence, LOC seems all the more probable (para. 148). The consumer may consider they come from the same undertaking or economically linked undertakings because they are accustomed to seeing in the marketplace several versions of the same mark, owned by one proprietor (paras 149, 150).



**2. Outcome: No likelihood of confusion (NO LOC)**



**T-808/16; HISPANITAS JOY IS A CHOICE (fig.) / JOY; Jean Patou Worldwide Ltd v EUIPO**; Judgment of 30 January 2018; EU:T:2018:45; Language of the case: EN

EUTM application	Earlier trade mark
	<p style="text-align: center;">JOY</p>

The figurative mark above was sought to be registered as an EUTM for goods in Classes 3, 14, 16, 18 and 25. An opposition based on the earlier word mark **JOY** registered for goods in Class 3 was filed pursuant to Article 8(1)(b) EUTMR. The Opposition Division (OD) upheld the opposition insofar as it found likelihood of confusion. The Board of Appeal (BoA) upheld the opponent’s appeal as it found there was no likelihood of confusion, given the lack of any similarity between the signs. The opponent filed an action before the General Court (GC) relying on a single plea in law: infringement of Article 8(1)(b) EUTMR. **Relevant public.** The relevant public is the EU general public with an average to high level of attention, given that the goods may be ordinary goods or luxury goods (para. 12). **Comparison of goods.** The goods are identical, since *perfumes* in Class 3 are included in the broader category of *perfumery* of the earlier mark (para. 13). **Comparison of signs.** The dominant element of the contested mark is the word ‘hispanitas’, due to its prominent position in the first line and its considerably larger and darker print. As part of a whole sentence, the word ‘joy’ is conjoined with other words in such a way that the independent distinctive role of the earlier mark is removed in the contested sign, where it is perceived as an inseparable part of a slogan, merely illustrating the dominant word ‘hispanitas’. The signs are similar only to a very low degree, because of their clearly different length and composition (para. 53). **No LOC.** Despite the identity between the goods and the presumed enhanced distinctive character of the earlier mark (which was duly taken into account), the marks produce a significantly different overall impression in the minds of the relevant public; in the contested mark, the word element ‘joy’ cannot be disassociated from the phrase it forms part of and plays only a secondary role in that mark (para. 54). Even assuming the combination of a ‘house mark’ with ‘product marks’ in the contested mark, it could not be inferred from this that such a usage is common to the entire perfumery sector and could be presumed to be known by the average consumer of perfumes (para. 34).



**T-795/16; CRABS (fig.) / RAKOVYE SHEIKI KARAMEL (fig.);** *Moscow Confectionery Factory ‘Krasnyiy oktyabr’ OAO v EUIPO*; Judgment of 7 February 2018; EU:T:2018:73; Language of the case: EN

EUTM application	Earlier trade mark
	

The applicant sought to register the figurative mark above as an international registration designating the EU for goods in Class 30. An opposition based on the earlier figurative mark above registered for goods in Class 30 was filed pursuant to Article 8(1)(b) EUTMR. The Opposition Division (OD) dismissed the opposition insofar as it found no likelihood of confusion, since irrespective of the identity between the goods and the conceptual similarity of the pictures of crayfish, the visual and phonetic differences between the signs, in particular as regards their word elements, were sufficient to offset the similarities. The opponent appealed against the OD’s decision and the Board of Appeal (BoA) dismissed the opponent’s appeal, since it found that the differences between the signs outweigh the similarities and, regardless of the identity between the goods and the low to average degree of attention of the public, there is no likelihood of confusion. The opponent filed an action before the General Court (GC) relying on a single plea in law: infringement of Article 8(1)(b) EUTMR. **Relevant public.** The relevant public is the public at large with a low to average level of attention. The relevant territories are Bulgaria, Benelux, Germany, Greece, Spain, France, Croatia, Italy, Cyprus, Latvia, Lithuania, Poland, Portugal, Romania, Slovakia and the United Kingdom (para. 21). **Comparison of the goods.** The goods covered are identical (*candy*) (para. 23). **Comparison of the signs.** The word ‘crabs’ is the most distinctive and dominant element of the contested mark while in the earlier mark it is the representations of crayfish that dominate. On the contrary, the latter are perceived as serving purely decorative purposes in the contested mark (para. 37). The signs are visually similar only to a low degree, since they have in common depictions of crayfish (although with differences between them), whereas they are different in their structure, word elements and other figurative elements (paras 52 and 55). Aurally, the signs are either different for the public able to read the Cyrillic alphabet or incomparable insofar as the remainder of the public was not able to pronounce the word element in Cyrillic letters (para. 58). The signs are conceptually similar since they both contain representations of crayfish and their word elements are meaningless for the parts of the relevant public who don’t understand Russian or Bulgarian so as to be able to grasp the meaning of the word element ‘раковые шейки’ or who do not understand English or French so as to be able to understand the word element ‘crabs’ (para. 59). Therefore, the signs are similar only to a low degree. **Distinctiveness of the earlier mark.** A mark does not have a higher degree of distinctiveness just because it has no conceptual link to the relevant goods. The evidence provided regarding Russia, Ukraine and Belarus did not relate to the relevant territories (paras 68 and 70). **LOC.** The differences between the signs, especially the clearly recognisable visual differences in their structures and their overall impressions, outweigh



their similarities and, therefore, there is no likelihood of confusion even for the identical goods (para. 83).

♦[T-118/16](#); **BEPOST /ePOST (fig.) et al.**; *Deutsche Post AG v EUIPO*; Judgment of 20 February 2018; EU:T:2018:86; Language of the case: EN

EUTM application	Earlier rights
BEPOST	<p style="text-align: center;">POST</p>  <p style="text-align: center;">Non-registered mark: POST</p>

The word mark **BEPOST** was sought to be registered as an EUTMR covering the goods and services in Classes 16, 35, 38 and 39. An opposition was filed, inter alia, on the earlier German word mark **POST** (services in Classes 35 and 39) and the EU figurative mark above (goods and services in Classes 9, 35, 36, 38, 39, 40, 41 and 42) and the non-registered mark or sign used in the course of trade **POST**. The grounds invoked were based on infringement of Article 8(1)(b) and Articles 8(4) and 8(5) EUTMR. The Opposition Division (OD) dismissed the opposition and the opponent appealed. The Board of Appeal (BoA) dismissed the appeal, insofar as it found that the signs showed significant visual, aural and conceptual differences which were sufficient to rule out a likelihood of confusion, as required by Article 8(1) EUTMR and national law. The possibility of association or the creation of a mental link for the purpose of Article 8(5) EUTMR was rejected taking into account that the German word ‘post’ was a generic term widely used to refer to postal and related services. The opponent filed an action before the General Court (GC) relying on three pleas in law: (i) infringement of Article 8(1)(b) EUTMR, (ii) infringement of Article 8(4) EUTMR and (iii) infringement of Article 8(5) EUTMR. **On the earlier German word mark post. Relevant public.** The relevant public is composed of professionals and consumers in Germany with an overall average level of attention (para. 31). **Comparison of goods and services.** The contested mark’s goods and services are identical, similar or remotely similar to the opponent’s services (para. 33). **Comparison of signs.** The signs showed, despite their (weak) common element ‘post’, significant visual, aural and conceptual differences, because of the difference in the length of the word elements as well as the slightly dominant word element ‘be’ at the beginning of the contested mark, which does not allude to postal services (paras 43-49). Although a significant percentage of the relevant public recognises the trade mark significance of the word ‘post’, that does not, by itself, demonstrate that said term can be perceived only as that mark when it is incorporated in marks which differ in overall appearance, pronunciation and concept (para. 47). **No LOC.** In order to assess LOC, the BoA duly took into account the proof of enhanced distinctiveness of the earlier mark and correctly assessed the distinctiveness and dominance of the components of the marks, the degree of similarity of the marks and the goods and services, as well as the fact that the element ‘BE’ of the contested sign was placed at the beginning of the short contested mark and was slightly dominant. No LOC confirmed (para. 72). **On the eu figurative mark  . Relevant public.** The relevant public is composed of consumers in the EU (para. 74). **Comparison of goods and services.** Part of the goods and services are dissimilar, part identical or at least somewhat similar (para. 75). **Comparison of signs.** Visually the signs are similar to a low degree, inter alia, because the first word element of the earlier figurative mark is ‘e’ whereas the first word element of the



contested mark is ‘be’ There are further visual differences resulting from the different colours and typefaces used and the way in which those different elements are arranged and the distinctive character of those elements is no weaker than that of the word element ‘post’ (para. 81). The ‘e’ in the earlier mark ePOST will be understood as meaning ‘electronic, indicating the involvement of the internet’, which represents a conceptual difference between it and the mark applied for (para. 83). **No LOC.** The distinctive character of the two word elements ‘e’ and ‘post’ of the earlier EU figurative mark ePOST is weak (para. 88). The signs are similar to a low degree, since, despite their common element ‘post’, they show significant visual, aural and conceptual differences (para. 89). The common element ‘post’, which is not separated from the word element ‘be’ by a space, does not play the same role in the two marks at issue (paras 69 and 91). Even if the common element ‘post’ may potentially have some independent distinctiveness due to the registration of the sign **POST** as an earlier national word mark, it is rather likely to be seen as a mere reference to postal services in the contested mark, and, therefore, it is purely descriptive (paras 91-92). Therefore, due to the above and given the different overall impression of the marks because of the differences between the word elements at the beginning of the signs in different graphic styles, there is no LOC (para. 90). The same applies for the non-registered mark or sign used in the course of trade **POST** (paras 101-102).

♦ [T-179/17](#); **NYouX (fig.) / NUXE**; *Laboratoire Nuxe v EUIPO*; Judgment of 21 February 2018; EU:T:2018:89; Language of the case: FR

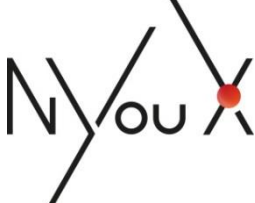

EUTM application	Earlier right
	<p style="text-align: center;"><b>NUXE</b></p>

The applicant sought to register the figurative sign above for goods in Classes 8, 11 and 26. An opposition based on the French earlier word mark, above registered for goods in Classes 3, 8, 11 and 26 was filed pursuant to Article 8(1)(b) EUTMR. Given the low degree of similarity of the signs and the average degree of distinctiveness of the earlier mark for the goods in Classes 8, 11 and 26, the Opposition Division (OD) dismissed the opposition in spite of the identity/similarity of the goods. OD did not examine the similarity of the *hair-cutting device, hairdryers and hairdressing accessories* in Classes 8, 11 and 26 with cosmetics for which enhanced distinctiveness was claimed. Upon the opponent’s appeal, the Board of Appeal (BoA) dismissed the appeal for the same reasons, without examining whether a different solution could be reached if the contested goods in Classes 8, 11 and 26 were compared to the goods in Class 3, and if the enhanced distinctiveness of the earlier mark for cosmetics was substantiated. The applicant filed an action before the General Court (GC), relying on two pleas in law: (i) infringement of the obligation to state reasons and (ii) infringement of Article 8(1)(b) EUTMR. **Obligation to state reasons.** The BoA observed that the earlier mark has an average intrinsic distinctive character as there is no conceptual link to the goods in question (para. 22). The BoA considered that the visual and oral similarity of the signs was low and there was no conceptual similarity (para. 30), but it also considered that the signs were different overall (para. 35). These two findings cannot be reconciled because if the similarity of the signs was low, it was necessary to



carry out an overall assessment of the likelihood of confusion (LOC), whereas it was not necessary if the signs were different (para. 36). **Likelihood of confusion.** The relevant public is the general public and hairdressing professionals of France with an average level of attention (para. 48). **Comparison of the signs.** The signs at issue can be differentiated as the earlier mark has four letters ('n', 'u', 'x' and 'e') and the contested mark has five ('n', 'y', 'o', 'u' and 'x') (para. 54). The only letter that has the same position in the two signs is the letter 'n' (para. 55). Moreover, the earlier mark is a word mark, and the particular graphic or stylistic aspects that it might adopt are irrelevant (para. 56). The contested sign is a composite mark characterised by the letters 'n', 'y' and 'x' written in upper-case letters, with a truncated form for the letter 'n', the letters 'y' and 'x' with different proportions and the colour red of the letter 'x' (para. 57). So the BoA concluded that the visual similarity was low (paras 58 and 63) and the arguments of the applicant cannot be taken into account (paras 61-63). Regarding the phonetic aspect, as there is no possible conceptual comparison the contested mark cannot be associated with the English word 'new' or with New York City as argued by the Office (paras 65 and 68). The letter 'x' will be pronounced by a large part of the relevant public (paras 71-72). The signs formed by two syllables have the same sound at the beginning with the letter 'n' and at the end with the letter 'x', so there is a high degree of phonetic similarity (paras 73-74). There is no conceptual similarity as the signs have no meaning (para. 75). Since the signs are similar, LOC could not be ruled out on the ground that one of the two conditions for the application of Article 8(1)(b) was missing (para. 76).

♦ **T-210/17; TRIPLE TURBO / ZITRO TURBO 2 (fig.);** *International Gaming Projects Ltd v EUIPO*; Judgment of 22 February 2018; EU:T:2018:91; Language of the case: ES



EUTM application	Earlier trade mark
	

The EUTM applicant sought to register the figurative sign above for goods in Classes 9 and 28. An opposition based on the earlier figurative mark above for the aforementioned goods was filed pursuant to Article 8(1)(b) EUTMR. The Opposition Division (OD) dismissed the opposition insofar as it found no likelihood of confusion. The opponent appealed the OD's decision and the Board of Appeal (BoA) annulled the OD's decision because it found that the relevant public was the general public composed of moderately attentive and informed consumers, as well as professionals, whose level of attention was higher than that of the general public, that the contested goods and the opponent's goods were identical or similar, and that the signs were visually, phonetically and conceptually similar. The EUTM applicant filed an action before the General Court (GC) relying on a single plea in law: infringement of Article 8(1)(b) EUTMR. **Relevant public.** The relevant public is the general public composed of moderately attentive and informed consumers, as well as professionals, whose level of attention is higher than that of the general public (para. 17). **Comparison of the goods.** The goods covered are identical or similar (para. 20). **Comparison of the signs.** The word 'turbo' and the figurative element of a smiling face wearing a racing helmet is the most distinctive and dominant element of the earlier mark (para. 41) while in the contested mark it is the words 'triple' and 'turbo' that dominate (para. 47). Even if both marks have the word 'turbo', with a weak distinctive character, it is not considered



dominant. The BoA wrongly estimated that just the presence of the word ‘turbo’ could implicate a visual similarity (para. 51). The signs at issue have differences: the fonts and the colours of the word ‘turbo’ are different; the earlier mark has a single verbal element that is horizontally aligned while the contested mark has two verbal elements that are curved; the figurative element (the face) of the earlier mark; the verbal element ‘triple’ is included in the contested mark (para. 52). The colour green is used in the word ‘turbo’ in the earlier mark and in the word ‘triple’ in the contested mark (para. 53). The BoA wrongly found the phonetic similarity relevant, as the word ‘triple’ is as important as the word ‘turbo’; the number of syllables in the contested mark is twice that of the earlier mark; and the word ‘triple’ is the initial part of the sign to which the consumer will pay more attention (para. 59). Finally, the BoA was right in finding a conceptual similarity as both signs refer to the original meaning of the notion of ‘turbo’ and they both refer to the speed of motor vehicles (paras 63-64). As the signs at issue only coincide in the term TURBO, which has a low degree of distinctiveness, the graphic differences will dominate the global impression of the signs in conflict and will offset the similarity resulting from the common term TURBO. There is no likelihood of confusion (paras 72-76).

♦ **T-6/17; BLACK LABEL BY EQUIVALENZA (fig.) / LABELL (fig.); *Equivalenza Manufactory, SL v EUIPO***; Judgment of 7 March 2018; EU:T:2018:119; Language of the case: ES

EUTM application	Earlier trade mark
	



The EUTM applicant sought to register the figurative sign above for the goods in Class 3 (*perfumery*). An opposition based on the earlier trade mark above was filed pursuant to Article 8(1)(b) EUTMR designating the Kingdom of Belgium, the Republic of Bulgaria, the Czech Republic, the Kingdom of Denmark, the Republic of Estonia, the Hellenic Republic, the Republic of Croatia, the Republic of Latvia, the Republic of Lithuania, the Grand Duchy of Luxembourg, Hungary, the Kingdom of the Netherlands, the Republic of Austria, the Republic of Poland, the Portuguese Republic, Romania, the Republic of Slovenia and the Slovak Republic for the abovementioned goods in Class 3 and for those with the following description: *cologne, deodorants for personal use (perfume), perfumes*. The Opposition Division (OD) upheld the opposition because of the existence of a likelihood of confusion (LOC) in the minds of the relevant public in Czechia, Hungary, the Republic of Poland and the Republic of Slovenia. The applicant appealed against the OD’s decision, which was dismissed by the Board of Appeal (BoA). It found that the relevant public was the general public with an average level of attention; that the goods were identical; that the signs were visually and phonetically similar to an average degree and that there were conceptual differences; that the applicant had not demonstrated that other marks containing the word ‘label’ coexisted on the market without any risk of LOC; and concluded that there was a LOC. The EUTM applicant filed an action before the General Court (GC) relying on a single plea in law: infringement of Article 8(1)(b) EUTMR. **Relevant public.** The relevant territory





was the Czechia, Hungary, the Republic of Poland and the Republic of Slovenia and the relevant public was composed of the general public with an average level of attention. The parties did not challenge these findings (para. 17). **Comparison of the goods.** The goods are identical; the parties did not challenge this finding either (para. 18). **Comparison of the signs.** The contested mark is composed of four words ('black', 'label', 'by' and 'equivalenza') while the earlier mark has only one ('labell') (para. 30). Moreover, the black quadrilateral geometric shape and the two small stylised leaves present in the mark applied for are very different from the blue oval shape shown in the earlier mark. The blue colour of the oval shape is visible and bright enough to not be confused with the black colour of the contested mark (para. 31). So the signs at issue are visually dissimilar (para. 32) and the BoA was incorrect in finding a visual similarity between the signs. The signs at issue are phonetically similar to an average degree as the words 'label' and 'labell' will be pronounced the same way (para. 36); and the other words may be not pronounced because of their position at the end of the sign (para. 38). Conceptually, the signs are dissimilar to the limited extent that the words 'black' and 'by equivalenza' are present in the contested mark. 'Black' is a basic English word understood by the public and qualifies the word 'label', which has no meaning for the relevant public, whereas the words 'by equivalenza' indicate that the goods originate from the trade mark applicant, but do not distinguish the marks because the earlier mark does not indicate a different origin (paras 40-45). The visual aspect of the signs at issue is more important than the phonetic and conceptual aspects of those signs (para. 52). The word and figurative elements of the signs have numerous and important visual differences, so the BoA should have considered that the signs were visually dissimilar (para. 53). Moreover, there is a conceptual difference between the signs due to the existence of the elements 'black' and 'by equivalenza' (para. 54). Therefore, because of the differences between the signs and notwithstanding the phonetic similarity to an average degree, the signs at issue are, in the overall assessment, not similar pursuant to Article 8(1)(b) (para. 55). There is no LOC pursuant to Article 8(1)(b) (para. 56).

♦ [T-159/17](#); **Desde 1972 Claro Sol Facility Services (fig.) / SOL (fig.);** *Claro Sol Cleaning, SLU v EUIPO*; Judgment of 8 March 2018; EU:T:2018:123; Language of the case: EN

EUTM application	Earlier trade mark
	

The applicant sought to register the figurative mark above as an EUTM for services in Classes 35, 37 and 39. An opposition based on the earlier Finnish figurative mark above, registered for services in the above classes was filed pursuant to Article 8(1)(b) EUTMR. The Opposition Division (OD) dismissed the opposition insofar as it found there was no likelihood of confusion. The opponent appealed and the Board of Appeal (BoA) partially upheld the appeal, since it found likelihood of confusion (LOC) (visual similarity and average phonetic similarity of the signs) for the services which were identical or similar. The applicant filed an action before the General Court (GC) relying on a single plea in law: infringement of Article 8(1)(b) EUTMR. **Relevant public.** The relevant territory is that of Finland and the consumer's level of attention is average to high. **Comparison of services.**



The services concerned are identical or similar. **Comparison of signs.** (i) the signs are visually similar, since the presence of the common element ‘sol’ is offset by the fact that, in the contested mark: (a) the element ‘claro’ is the first element to be seen, (b) the typographic characters in the signs, and in particular those of the element ‘sol’, are different, (c) there are other non-negligible word elements in the contested mark and (d) the other figurative elements of which it consists are also striking. The words ‘claro’ and ‘sol’ are not the dominant elements in the contested mark, since the element ‘desde 1972’ is not negligible in the overall impression and the composite figurative element will be clearly memorised by the relevant public (paras 42 and 49). (ii) The signs have limited phonetic similarity, since the presence of the word element ‘claro’ in the contested mark (the pronunciation of which is very audible, consisting of two syllables and being the first element) strongly offsets the similarity with the earlier mark, which consists solely of the monosyllabic element ‘sol’. The element ‘desde 1972’, in spite of its size and where it is placed, might also be pronounced by the Finnish public because of the fact that the word ‘desde’ has no meaning (paras 53 and 55). (iii) There is some degree of conceptual similarity insofar that for the Finnish public, which is easily able to understand Swedish (as an official language of Finland), the signs coincide in the meaning of the element ‘sol’, which will be understood as a reference to the sun. However, in the contested mark, the presence of the elements ‘claro’ and ‘desde 1972’, which have no meaning in either of the official languages of Finland, offsets that similarity. Furthermore, consumers normally attach more importance to the first part of a trade mark (paras 60-61). **No LOC.** Despite the identity or similarity of the services concerned and the average to high level of attention of the relevant public, and given the differences identified between the signs, there is no LOC.

**T-390/16; DONTORO dog friendship (fig.) /TORO et al.; Grupo Osborne, SA v EUIPO;** Judgment of 20 March 2018; EU:T:2018:156; Language of the case: EN



EUTM application	Earlier trade mark
	<p style="text-align: center;">TORO</p>

The applicant sought to register the figurative mark above as an EUTM for goods and services in Classes 18, 20, 25 and 35. An opposition based, inter alia, on the earlier EU word mark **TORO** registered for goods in Classes 18 and 25 was filed pursuant to Article 8(1)(b) EUTMR. The Opposition Division (OD) partially upheld the opposition as it found likelihood of confusion (LOC) except for some of the services in Class 35. The OD’s decision was appealed by the opponent and the Board of Appeal (BoA) partially upheld the appeal. It found LOC for contested goods in Class 25 due to their identity to the opponent’s *clothing, footwear, headgear; belts*. The opponent filed an action before the General Court (GC) relying on a single plea in law: infringement of Article 8(1)(b) EUTMR. **Relevant public.** The relevant public of the contested mark is both the general public and professionals, with an average to high level of attention. The relevant public of the earlier mark is the EU general public with an average level of attention (para. 22). **Comparison of the goods and services.** The opponent’s goods, namely, *clothing and footwear*, have a certain degree of similarity to the contested services of wholesaling, retailing and mail order sales of these goods because they are complementary, but differ in their nature, intended



purpose and method of use (paras 29-33). **Comparison of signs.** (i) The signs have a certain degree of visual similarity since the element ‘toro’ is the most distinctive element of the contested mark as regards the Spanish- and Italian-speaking parts of the relevant public and constitutes in itself the earlier mark (para. 45). (ii) The signs are phonetically similar to a low degree, since they coincide in the element ‘toro’, but they have a different pronunciation due to the expression ‘dog friendship’ in the contested mark. Moreover, the contested mark is composed of three words and six syllables, in contrast to the earlier mark, which consists of one word and two syllables (paras 48 and 51). (iii) The signs are conceptually similar to an average or even low degree: although the common reference to the concept of a bull is evident, the figurative element representing a crown and the phrase ‘dog friendship’ in the contested mark convey a concept which is distant from the classic concept of a bull as an animal or as a family name (paras 55-56). **Likelihood of confusion.** The visual, phonetic and conceptual differences between the signs are sufficient for the contested mark’s services not to appear, in the eyes of the relevant public, as originating from the undertaking which is the proprietor of the earlier mark (para. 60).

♦[T-648/16](#); **BOBO cornet** [www.bobo-cornet.com](http://www.bobo-cornet.com) (fig.) / **OZMO cornet** (fig.); *Şölen Çikolata Gıda Sanayi ve Ticaret AŞ v EUIPO*; Judgment of 17 April 2018; EU:T:2018:194; Language of the case: EN

EUTM application	Earlier trade mark
	

The EUTM applicant sought to register the figurative sign above for goods in Classes 29, 30 and 32. An opposition based on the earlier international registration above was filed pursuant to Article 8(1)(b) EUTMR. It was based on all the goods of the earlier registration, namely goods in Class 30, and directed against all the goods of the EU trade mark application. The Opposition Division (OD) rejected the opposition in its entirety. The opponent filed an appeal which was dismissed by the Board of Appeal (BoA). It found that the signs are visually dissimilar; aurally similar to a less than average degree; and conceptually void and deduced that there was no likelihood of confusion (LOC). The opponent filed an action before the General Court (GC) relying on two pleas in law: (i) infringement of Article 8(1)(b) EUTMR and (ii) infringement of Article 74 EUTMR and, more particularly, breach of the duty to state reasons, infringement of Article 95(1) EUTMR and breach of the duty of diligence. **Relevant public.** The relevant territory consists of the Member States designated by that international registration, namely Belgium, Bulgaria, Czechia, Denmark, Germany, Spain, France, Croatia, Italy, Luxembourg, the Netherlands, Austria, Poland, Portugal, Romania, Slovenia, Slovakia and the United Kingdom. The goods in question are everyday consumer goods directed at the public at large, who will display an average level of attention (para. 27). **Comparison of the signs.** The representation of the rabbit holding an ice cream cornet occupies two thirds of the mark



applied for and that constitutes a particularly striking feature of that sign (para. 36). The verbal elements ‘bobo’ and ‘cornet’ of the mark occupy a less prominent position than the representation of the rabbit. Among those verbal elements ‘bobo’ has more of a visual impact than the final element ‘cornet’, given the larger size of its letters (para. 37). The element ‘ozmo’ in the earlier mark is likely to have a greater visual impact than the element ‘cornet’ as it is written in larger letters and it is framed by a thin black line (para. 38). The mark applied for can be distinguished by the representation of the rabbit holding an ice cream cornet which dominates its visual representation. Furthermore, the words ‘bobo’ and ‘ozmo’, which will be regarded as being visually more important than the common word ‘cornet’, will be perceived by the relevant public as being visually different. **The signs are visually dissimilar** (para. 39). The words ‘bobo’ and ‘ozmo’ have a greater phonetic impact than the word ‘cornet’ as it is likely that, as the marks constitute a relatively long combination, the relevant public will pronounce only the first word. That will be the case in particular for the part of the relevant public which will understand the word ‘cornet’ and perceive it as having a descriptive character (para. 57). The words ‘bobo’ and ‘ozmo’ are pronounced very differently. **The degree of phonetic similarity of the marks is below average** (para. 63). Due to the descriptive and, therefore, non-distinctive character of the common word ‘cornet’, having regard to the absence of any concept conveyed by the words ‘bobo’ and ‘ozmo’ and the presence of a dominant figurative element in the mark applied for, the coincidence in the verbal element ‘cornet’ **cannot introduce even a low degree of conceptual similarity** (para. 80). **No LOC**. Given the dominant character of the rabbit holding the cornet, the visual and phonetic difference between the marks with regard to the words ‘bobo’ and ‘ozmo’, and the secondary character of the word ‘cornet’, the BoA was correct to find that there is no LOC between those marks (para. 95).

♦[T-25/17](#); **PROTICURD / PROTIPLUS et al.**; *Bernhard Rintisch v EUIPO*; Judgment of 19 April 2018; EU:T:2018:195; Language of the case: EN

IR designating the EU	Earlier trade marks
<p><b>PROTICURD</b></p>	<p><b>PROTI PROTIPLUS</b></p> 

The international registration designating the European Union of the word mark **PROTICURD** was notified to the Office for registration for goods in Classes 5 and 29. An opposition based on the earlier German word marks **PROTI** and **PROTIPLUS** (Classes 29 and 32), as well as the German figurative mark above, was filed pursuant to Article 8(1)(b) EUTMR. The Opposition Division (OD) upheld the opposition and the IR holder appealed. The Board of Appeal (BoA) partially upheld the appeal and rejected the opposition for all the contested mark’s goods in Class 5 (*pharmaceutical preparations; dietetic substances for medical purposes, dietetic preparations, dietary supplements, parapharmaceutical products, all for medical purposes*), and some of the goods in Class 29, namely *milk powders and milk beverages, with milk predominating*. The opponent filed an action before the General Court (GC) relying, inter alia, on the infringement of Article 8(1)(b) EUTMR. The GC upheld the plea in law based on the infringement of the duty to state reasons and annulled the BoA’s decision. The case was referred to the BoA for a new ruling which



annulled the OD’s decision. The opponent filed an action before the GC relying on three pleas in law: (i) infringement of Article 94 EUTMR, (ii) infringement of Article 47(2) EUTMR, and (iii) infringement of Article 8(1)(b) EUTMR. **Relevant public.** The relevant public consisted of consumers in Germany presumed to be reasonably well informed (para. 78). **Comparison of the goods.** The main purpose of the earlier mark’s goods in Class 32 (*dietary supplements in the field of sport and fitness*) is different from that of the contested mark’s goods in Class 5 (*medical use*) and, therefore, they are different (paras 91, 98 and 101). Moreover, there is only a remote similarity between the contested mark’s goods in Class 29 (*milk powders, milk beverages, with milk predominating*) and the earlier mark’s goods in Class 32 (paras 106). **Comparison of the signs.** Visually and aurally, the signs are similar to a medium degree, as the word mark ‘PROTI’ is found entirely at the beginning of the word mark ‘PROTICURD’ and consumers normally attach more importance to the beginnings of words. However, the English term ‘curd’ or ‘curds’ (curdled milk) is not part of the usual English vocabulary of the German-speaking public. Moreover, there is no similarity between the English term ‘curd’ and its counterpart in German, ‘quark’ (paras 109-110). **No LOC.** Since the term ‘curd’ is not part of the usual vocabulary of the relevant public, it will not be construed as descriptive and ‘PROTICURD’ will not be perceived as belonging to a family of marks comprising the word component ‘proti’ (para. 123). Despite the medium degree of similarity of the signs, there is no likelihood of confusion between the signs, due to the difference or low similarity between the goods concerned (para. 124).

**T-221/17; MEMORAME / MÉMORA et al.;** *Mémora Servicios Funerarios SLU v EUIPO*; Judgment of 24 April 2018; EU:T:2018:214; Language of the case: ES

EUTM application	Earlier trade mark
MEMORAME	

The EUTM applicant sought to register the word mark above for the goods and services in Classes 9, 35, 38 and 42. An opposition based on three earlier marks (the EU figurative mark above, and two Spanish word marks **MÉMORA**) was filed pursuant to Article 8(1)(b) and Article 8(5) EUTMR. The Opposition Division (OD) partially upheld the opposition as the services in Classes 35 and 45 were similar to services in Classes 35 and 42. However, the OD dismissed the opposition for the goods and services in Classes 9, 38 and 42 because of a lack of similarity between them and also under Article 8(5) EUTMR. The opponent filed an appeal against the OD’s decision. The Board of Appeal (BoA) dismissed the appeal as it found that the contested mark’s goods and services were not similar to the earlier marks’ services. Moreover, it rejected the arguments based on Article 8(5) EUTMR as they were not substantiated. The opponent filed an appeal before the General Court (GC), relying on infringement of Article 8(1)(b) in conjunction with Article 8(5) EUTMR. **Likelihood of confusion.** The trade mark applicant’s software functions as a management tool for professionals specialising in the funeral sector and not as a channel for the search and purchase of funeral services by the general public. Therefore, the contested mark’s goods in Class 9 do not target the same public as the opponent’s morgue and funeral services in Class 45, so the goods and services are not similar (para. 32). These goods and services are not complementary insofar as the contested mark’s goods in Class 9 target a professional public specialised in the administration and management of cemeteries,



whereas the opponent's services in Class 45 target the general public (para. 36). The BoA found that the services of the opponent in Classes 35 and 36 were general consulting services for managers and corporate directors, while the applicant's goods and services in Classes 9, 38 and 42 were tools and activities specifically designed for exploiting cemeteries. The destination and the relevant public of the opponent's services in Classes 35 and 36 are irrelevant to cemeteries. Therefore, these services are different from the contested mark's goods and services (para. 37). The BoA found that the contested mark's goods in Class 9 were not similar to the opponent's services in Classes 35, 36 and 45 (para. 38). The contested mark's services in Class 38 target directors and administrators of cemeteries, whereas the earlier marks' services in Class 45 target the general public (para. 40). Therefore, the BoA found that the contested mark's services in Class 38 were not similar to those in Classes 35, 36 and 45 (para. 41). The BoA confirmed that the contested mark's services in Class 42 were not similar to those of the earlier marks (para. 43). There was no contradictory reasoning as the OD stated that the contested mark's services in Class 42 were slightly similar to the earlier marks' services in Class 45. This was because the relevant public was the same and they were provided through similar distribution channels. Additionally, OD found that there was also a degree of similarity between these different services regarding their purpose. Both the OD and the BoA considered that the contested mark's services in Class 42 targeted specialised professionals different from the general public of those in Class 45. They also stated that the goods and services were not complementary to the extent that the use of a funeral service only requires calling a funeral parlour, not managing software and a database (para. 44). Therefore, the BoA found that the contested mark's goods and services in Class 42 were not similar to the earlier marks' services in Classes 35, 36 and 45 (para. 46).

**Reputation.** The opponent only submitted documents to prove the reputation of the earlier marks before the GC. However, these cannot be taken into consideration as the function of the GC is not to re-examine the factual circumstances in light of the documents submitted for the first time before it (paras 53-54).

♦ [T-554/14](#); **MESSI (fig.) / MASSI et al.**; *Lionel Andrés Messi Cuccittini v EUIPO*; Judgment of 26 April 2018; EU:T:2018:230; Language of the case: ES



EUTM application	Earlier trade mark
	<p style="text-align: center;"><b>MASSI</b></p>

The applicant sought to register the figurative mark above as an EUTM for goods in, inter alia, Classes 9, 25 and 28. An opposition based on the earlier word mark **MASSI** registered for goods in, inter alia, Classes 9, 25 or 28 was filed pursuant to Article 8(1)(b) EUTMR. The Opposition Division (OD) upheld the opposition and the applicant appealed. The Board of Appeal (BoA) dismissed the appeal, finding that there was likelihood of confusion (LOC) between **MESSI** and **MASSI**. This was due to the identical or extreme similarity of the



goods and the similarity of the signs. The latter resulted from the visual and phonetic quasi-identity of the signs' dominant elements. The BoA held the signs were conceptually distinguished only by part of the relevant public. However, the signs were also practically visually and phonetically identical, counteracting the conceptual difference. The applicant filed an action before the General Court (GC) relying on a single plea in law: infringement of Article 8(1)(b) EUTMR. **Relevant public.** The relevant public consists of the ordinary consumers in the European Union buying clothing, sports goods and devices for protective purposes. They are reasonably informed, observant and circumspect (para. 38). **Comparison of goods.** The goods are identical in Classes 9 and 25 and the goods in Class 28 of the contested mark are similar, even highly, as regards goods in Class 9 of the earlier mark (helmets for cyclists) (para. 39). **Comparison of signs.** (i) Visually, the signs are similar because the dominant element 'MESSI' of the contested mark is extremely similar to the element 'MASSI' of the earlier mark (para. 43). However, this is an average degree of similarity as the figurative element of the mark applied for will be perceived by reasonably observant consumers as an ornamental element, reinforcing the word element (paras 45-46). (ii) The aural similarity of the marks is very high. The figurative element may be perceived as a purely decorative element and/or a reference to the first letter of the word element. Further, consumers generally simplify the pronunciation of words for the sake of language economy (paras 48-49). (iii) Conceptually, the signs are different: the football player Lionel Messi is a celebrity known by most of the [informed] public, and the well-known character of his surname is a well-known fact that could have been taken into account by the BoA. The GC considers this, although it is adduced for the first time, and holds that the BoA erroneously found that the relevant public, taken as a whole, will not associate the mark with the famous football player's surname, and that a possible conceptual distinction would only be made by part of the public (paras 52, 54, 61 and 63). **Likelihood of confusion.** Given the similarity or identity between the goods and the fact that the high conceptual differences counteract the visual and phonetic similarities, the degree of similarity between the signs is not sufficient to find LOC (paras 68 to 77).

♦ [T-241/16](#); **EW (fig.) / WE**; *El Corté Inglés, SA v EUIPO*; Judgment of 4 May 2018; EU:T:2018:55; Language of the case: EN

EUTM application	Earlier trade mark
	

The applicant sought to register the figurative mark above for goods in Classes 3, 18 and 25. An opposition based on the EU word mark **WE** for goods in Classes 3, 18 and 25 was filed pursuant to Article 8(1)(b) and Article 8(5) EUTMR. The Opposition Division (OD) upheld the opposition for all contested goods except for *walking sticks* in Class 18 and the Board of Appeal (BoA) dismissed the applicant's appeal. It found that there was likelihood of confusion (LOC) for all the goods that had been found to be identical, similar or similar to a low degree because the signs were visually and phonetically similar to an average degree. The applicant appealed an annulment before the General Court (GC) relying on a single plea in law, alleging infringement of Article 8(1)(b) EUTMR. **Visual similarity.** Contrary to the BoA the degree of visual similarity is merely low as, first, the letters 'w' and 'e' are not arranged in the same order and, secondly, although the typeface used in the mark applied for is indeed banal, it is, however, necessary to note the interconnection in the upper part of the letters 'e' and 'w' which, though barely visible, nevertheless strengthens



the impression that the mark applied for forms a single syllable and an indivisible whole (para. 35). **Phonetic similarity.** It is also only low and not average since the relevant Italian and Spanish public will pronounce the marks as ‘ve’ or ‘güe’, the earlier mark, and ‘ev’, the applied for mark, respectively. There is no phonetic similarity at all for the part of the public with knowledge of English, which will pronounce the earlier mark as /wi:/. **Conceptual similarity.** For the part of the public that does not understand English, the conceptual comparison is indeed neutral as the BoA held. The marks, however, are not similar for the part of the public that does have knowledge of English, since for them, the earlier mark has meaning whereas the mark applied for does not (paras 42-43). **Likelihood of confusion.** Since the signs are short, the differences between the marks will not escape the relevant public’s attention. In particular, the letter ‘w’ is little used in Spanish and Italian and its position in the marks will attract the public’s attention. There is no LOC for Spanish and Italian consumers (paras 54-55).

♦ [T-165/17](#); **EMCURE / Emcure et al.**; *Emcure Gesundheitsmittel aus Bad Ems GmbH v EUIPO*; Judgment of 14 June 2018; EU:T:2018:346; Language of the case: EN. The applicant sought to register the word mark **EMCURE** for services in Classes 35, 41, 42, 44 and 45. The opponent filed an opposition pursuant to Article 8(1)(b) EUTMR based on the EU word mark **EMCUR** registered for goods in Classes 5 and 10 and the German word mark **EMCUR** registered for goods in Class 5. The Opposition Division (OD) upheld the opposition in part, rejecting registration of the mark for *pharmacy advice* services in Class 44, on the basis that there was a likelihood of confusion (LOC) regarding the earlier German mark. The opponent appealed, but the Board of Appeal (BoA) dismissed the appeal. Despite the high degree of similarity of the signs, there was no LOC because none of the remaining contested services were similar to the goods of the earlier marks. The opponent appealed to the General Court (GC), relying on a single plea in law: infringement of Article 8(1)(b) EUTMR. **Comparison of the goods and services. Classes 35 and 41.** Insofar as the opponent’s goods and the contested services in Classes 35 and 41 are used by professionals, the relevant public overlaps to some extent (para. 39). However, contrary to the opponent’s position, the complementary connection between the opponent’s goods in Class 5 (*pharmaceuticals and healthcare preparations*) and the contested services in Classes 35 and 41 (*services for commercial, advertising, training and educational purposes in the area of healthcare*) was not established. Therefore, there is no similarity between those goods and services (paras 40 to 44). **Class 42.** The services in Class 42 are closely connected to pharmaceutical products (paras 49 and 50). The BoA erred in finding that the earlier German mark’s goods in Class 5 and the contested services in Class 42 were not similar (para. 53). **Class 44.** Medical services and pharmaceutical products target and are used by both professionals and the general public. Accordingly, those goods and services target the same consumers, have the same aim, have the same distribution channels, and are complementary (paras 56 to 60). The BoA erred in finding that the services in Class 44 and the earlier German mark’s goods were not similar (para. 61). **Class 45.** The opponent did not submit any argument challenging the contested decision’s legality for services in Class 45. Accordingly, the Court cannot uphold the annulment of the contested decision (paras 64 and 65). The BoA did not err in finding that there was no similarity between the services in Classes 35 and 41 and the goods in Class 35. Therefore, there was no LOC (para. 66). However, the BoA erred in finding that there was no LOC within the meaning of Article 8(1)(b) EUTMR on the part of the relevant public solely based on the incorrect finding that there was no similarity between the services in Classes 42 and 44 and the goods in Class 35 (para. 67).





**T-859/16; EISKELLER (fig.) / KELER et al.; Sociedad Anónima Damm v EUIPO;** Judgment of 19 June 2018; EU:C:2018:352; Language of the case: EN

EUTM application	Earlier trade mark
	<p style="text-align: center;">KELER</p>

An EUTM registration for the figurative mark above was sought for goods and services in Classes 32, 33 and 43. An opposition based on, inter alia, the Spanish word mark **KELER** for goods in Class 32 was filed pursuant to Article 8(1)(b) EUTMR. The Opposition Division (OD) upheld the opposition, but the Board of Appeal (BoA) dismissed the applicant’s appeal insofar as it found that there was no likelihood of confusion (LOC), as the signs were dissimilar overall. The opponent appealed to the General Court (GC) for the annulment of the BoA decision, relying on a single plea in law: infringement of Article 8(1)(b) EUTMR. **Distinctive and dominant elements.** The figurative element of the mark applied for will not be completely overshadowed by the word element ‘eiskeller’, given that it will be perceived as a heraldic symbol and because of its size and central location in the mark (paras 33-34). Furthermore, it is not possible to break down the word element ‘eiskeller’ into ‘eis’ and ‘keller’ as there are no typographical or other elements to suggest that and it has not been established that the relevant public will be able to perceive two conjoined words in the sign (paras 37-38). **Visual comparison.** Although all the letters making up the earlier mark are present in the same order in the word element of the mark applied for, the presence in the mark applied for of additional letters and of the figurative element, and its colour and stylisation, render the signs visually dissimilar overall (paras 43-46). **Phonetic comparison.** The assertion that Spanish consumers will pronounce the double ‘ll’ as ‘l’ on the ground that consumers will recognise the mark applied for as a foreign mark is not supported by any evidence; therefore, the pronunciation of the signs at issue coincides only in relation to the groups of letters ‘ke’ and ‘er’ (paras 58-59). The phonetic differences between the signs at issue are sufficient to rule out any similarity despite the noisy environment in which the ordering of the goods in question may take place (para. 69). **Conceptual comparison.** For Spanish consumers neither sign has a meaning and, in any case, they will not split the word element ‘eiskeller’ into two word elements (paras 63-64).

♦ **T-362/16; XENASA / PENTASA; Tillotts Pharma AG v EUIPO;** Judgment of 19 June 2018; EU:T:2018:354; Language of the case: EN. The applicant sought to register the word mark **XENASA** for the following goods in Class 5: *pharmaceutical preparations, namely for the diagnosis, prevention and / or treatment of gastrointestinal disorders and conditions; pharmaceutical preparations for the treatment of inflammation of the gastrointestinal tract; dietetic substances adapted for medical use, namely for the diagnosis, prevention and / or treatment of gastrointestinal disorders and conditions.* An opposition was filed covering *pharmaceutical products and substances* in Class 5 pursuant to Article 8(1)(b) EUTMR. The Opposition Division (OD) dismissed the opposition. The opponent appealed the OD’s decision. The Board of Appeal (BoA) upheld the appeal, overturning the OD’s decision, and refused to register the mark. It found that the relevant public consists of medical professionals and end users within the European Union; that some of the goods are identical and the remainder highly similar; that there is an average degree of visual and phonetic similarity between the signs; that the conceptual comparison is neutral; that the



earlier mark has a normal level of inherent distinctiveness and that there is a likelihood of confusion (LOC). The applicant appealed to the General Court (GC), relying on a single plea in law: infringement of Article 8(1)(b) EUTMR. **Relevant public.** The relevant public for the goods consists of the professional public and patients as end users with a high level of attention (paras 20-21). **Comparison of the goods.** The contested mark's goods in Class 5 fall within two broad categories: those in *pharmaceutical products and substances*, which are protected by the earlier mark, and which are identical; those in *dietetic food and substances adapted for medical or veterinary use, food for babies*, which are not protected by the earlier mark, and which are not identical, but very similar (para. 25). **Comparison of the signs.** It has not been established that all end users of the goods will perceive the shared suffix 'ASA' as a reference to the active ingredient '5-asa' or 'mesalazine'. These end users must be borne in mind when comparing the signs (para. 31). The mark applied for covers, inter alia, pharmaceutical preparations for the treatment of inflammation of the gastrointestinal tract. It cannot be excluded that some end users may regularly take medications containing the active ingredient and a significant number of those end users will perceive 'ASA' as a reference to this (para. 34). **Visual similarity.** The differences at the beginning and in the middle of the signs produce a different overall visual impression. The signs will have a lower than average degree of similarity for end users who do not perceive 'ASA' as a reference to the active ingredient (para. 42). The degree of visual similarity will be low for end users who perceive 'ASA' as a reference to the active ingredient. For these end users, the fact that the marks share the word element 'ASA' will thus have less importance, and they will notice the difference between the initial first letters more easily, as they normally attach more importance to the beginnings of words (para. 43). **Phonetic similarity.** The signs will have a lower than average degree of similarity for end users who do not perceive 'ASA' as a reference, whether they pronounce the mark applied for as the syllables 'XEN' 'A' 'SA' or as 'XE' 'NA' 'SA' (paras 50-52). Phonetic similarity will be low for end users who perceive 'ASA' as a reference, as it will be allusive and therefore less capable of identifying the goods as originating from a particular undertaking (para. 53). **Conceptual similarity.** The BoA found that the conceptual comparison is neutral for end users who do not perceive 'ASA' as a reference. That conclusion must be partly upheld for end users who do not perceive 'ASA' as a reference and who do not perceive the beginnings of the signs 'XEN' and 'PENTA' as references to the Greek word 'xenos' and the prefix of Greek origin 'penta'. The signs will have some conceptual similarity for end users who perceive 'ASA' as a reference, but who do not perceive the Greek word elements. There will be a conceptual difference between the signs for end users who perceive the Greek word elements (paras 55-58). **Likelihood of confusion.** There will be no LOC for end users who do not perceive 'ASA' as a reference and who do not perceive the Greek word elements (para. 68). The signs will have some conceptual similarity for end users who perceive 'ASA' as a reference, but do not perceive the Greek word elements. However, in this case, the visual and phonetic similarity will be low due to the allusive character of 'ASA', and therefore there will be no LOC (para. 69). There will also be no LOC for end users who perceive the Greek word elements (para. 70). The BoA erred in finding that there is LOC at least for a significant number of end users (para. 71).



**T-537/15; InPost / POST et al.; Deutsche Post AG v EUIPO**; Judgment of 26 June 2018; EU:T:2018:384; Language of the case: EN

EUTM application	Earlier trade marks
	<p style="text-align: center;"><b>POST</b></p> 

The applicant sought to register the figurative mark shown above as an EUTM for goods and services in Classes 6, 9, 35 and 39. An opposition was filed based on, inter alia, the earlier German word mark **POST** (Classes 35 and 39) and the EU figurative mark above (services in Classes 35 and 39). The Opposition Division (OD) partly dismissed the opposition for goods and services in Classes 9, 35 and 39 except for *business enquiries, research surveys, and organisation of exhibitions for commercial purposes*. The opponent appealed and the Board of Appeal (BoA) dismissed the appeal, finding no likelihood of confusion (LOC). The opponent filed an action before the General Court (GC), relying on two pleas in law: (i) infringement of Article 8(1)(b) EUTMR and (ii) infringement of Article 8(5) EUTMR. (i) **On POST. Relevant public.** It consists of both the general public and professionals in Germany (para. 34). **Comparison of services.** The services concerned are similar or identical, with the exception of *advertising space rental services* of the contested mark which is dissimilar (para. 36). **Comparison of signs.** (a) Visually, the signs are similar as they coincide in the common element ‘post’, but differ as the contested mark has a black and yellow envelope symbol and begins with the word element ‘in’ (para. 54). (b) Aurally, they are similar to a low degree, since the pronunciation of the marks coincides in the pronunciation of the term ‘post’ and differs in the additional word element ‘in’ of the contested mark (para. 48). (c) Conceptually, the signs are similar to a low degree, since they convey the meaning of the word ‘post’, but differ significantly in that the word element ‘in’ at the beginning of the contested mark, unlike the term ‘post’, does not refer to the services (para. 51). **No LOC.** Given the low degree of distinctiveness of the earlier mark and the differences between the signs, despite the identity of the services, there is no LOC. The mere fact that the earlier national word mark, **POST**, reached the threshold required to be registered as a national trade mark does not mean that the element ‘post’ has acquired enhanced distinctiveness or a reputation (paras 66, 67 and 80). (ii) **On INFOPOST. Relevant public.** It consists of consumers in the EU (para. 81). **Comparison of services.** Most of the services in Classes 35 and 39 are identical (para. 82). **Comparison of signs.** (a) Visually, the signs are similar to a low degree: despite their common element ‘post’, they differ due to the black and yellow envelope symbol and because the first word element of the earlier EU figurative mark is ‘info’, whereas the first word element of the contested mark is ‘in’. Furthermore, they use different colours and typefaces and a different arrangement of the figurative elements (paras 87-88). (b) Aurally, the signs coincide in the pronunciation of ‘in’ and ‘post’. They also differ as the earlier figurative EU mark has an additional syllable, ‘fo’. This additional syllable changes the pronunciation, forming the independent word ‘info’ which conveys its own meaning (para. 89). (c) Conceptually, they are different, since the word element ‘info’ in the earlier EU figurative mark will be understood by the relevant public as meaning ‘information’ (para. 90). **No LOC.** Given the different overall impressions of the marks and that the common element, ‘post’, has a low degree of distinctiveness, LOC cannot be substantiated (para. 97). (iii) The relevant public will not make any link between the contested mark and **POST**, since ‘post’ is generic and likely to be perceived as merely a reference to postal services (para. 112).



**T-825/16; Pallas Halloumi (fig.) / HALLOUMI; Republic of Cyprus v EUIPO; Judgment of 13 July 2018; EU:T:2018:482; Language of the case: EN**

EUTM application	Earlier trade mark
	<p style="text-align: center;"><b>HALLOUMI</b></p>

The applicant sought to register the figurative mark above, comprising the colour indications ‘yellow, red, blue, white, grey’, as an EUTM for goods in Class 29. An opposition based on, inter alia, the earlier UK certification word mark **HALLOUMI** (registered for goods in Class 29) was filed pursuant to Article 8(1)(b) EUTMR. The Opposition Division (OD) dismissed the opposition and the opponent appealed. The Board of Appeal (BoA) dismissed the appeal insofar as it found that there was no likelihood of confusion between the earlier mark and the contested mark. It took the view that the inherent distinctive character of the term ‘halloumi’ was weak: in the eyes of the Cypriot public, the word designated a particular type of cheese produced in Cyprus, and that finding must be extended to the relevant UK public. That word is older than all the trade marks and, as such, is, to the relevant public, descriptive of the characteristics and composition of the product. The opponent appealed to the General Court (GC), relying on a single plea in law: infringement of Article 8(1)(b) EUTMR. **Relevant public.** Since the earlier mark is a UK mark, the relevant public consists of average UK consumers, who are reasonably observant and circumspect, insofar as the products for which protection is sought are everyday consumer goods (para. 26). **Comparison of the goods.** The goods are identical (para. 26). **Comparison of the signs.** (i) The signs are similar to a low degree, since they coincide only in the element ‘halloumi’, which is of secondary importance, due to its font size and its place within the contested mark. The relevant public will pay more attention to the element ‘pallas’, which appears as the dominant element of the contested mark. The two red ovals and specific graphic stylisation also constitute a second significant difference between the signs (paras 60-61). (ii) The signs have an average degree of phonetic similarity since they only share the term ‘halloumi’, which is located in a secondary position in the contested mark. Therefore, the presence of the word ‘pallas’ in the contested mark provides a significant difference between the signs (paras 63-64). (iii) The signs are conceptually dissimilar insofar as the term ‘pallas’ has no particular meaning for the relevant public and is unconnected with the earlier mark, it introduces a significant conceptual difference. The presence of the term ‘halloumi’ does not constitute a significant element in conceptual terms. It has not been established that the public would understand it as a reference to a certification process to which the user of the trade mark is subject (paras 65-66). **Inherent distinctiveness.** Even if the word ‘halloumi’, registered as a national certification mark, has a certain degree of distinctiveness, this does not mean that it must be recognised as having distinctive character per se to a degree that would provide it with unconditional protection enabling opposition to any registration of a later mark including that term (para. 40). The evidence submitted, consisting in particular of data on sales volumes, on promotion and marketing efforts, extracts from cookery magazines or press articles and various written statements, relates to ‘Halloumi’ cheese as a speciality cheese from Cyprus. However, it is not possible to link the term ‘halloumi’, used generically, to any certification mark, or even to a reference to a certified cheese (para. 42). Even if the distinguishing function of United Kingdom certification marks must be understood as the ability to distinguish one class of goods from another class of goods, in the light of the evidence adduced by the Republic of



Cyprus, it has not been demonstrated that the earlier mark, as a United Kingdom certification mark, is capable of constituting an indication of the commercial origin of the goods in question. The existence of a likelihood of confusion on the specific conditions of Article 8(1)(b) EUTMR depends on that being demonstrated (para. 45) The word ‘halloumi’ is directly understood by the UK public as describing the characteristics or even the origin of the goods, but not as an indication of its certified quality, not even as an indication of that quality (para. 43). Due to its descriptive character, the earlier mark is distinctive only to a low degree (para. 47). **Likelihood of confusion.** The mere identity between the goods and the similarity of the signs as regards the common presence of the descriptive term ‘halloumi’ is not sufficient to create a likelihood of confusion, because of the weak distinctive character of the earlier mark and its descriptive meaning. There is no LOC (para. 83).

**T-847/16; COWBOYS HALLOUMI (fig.) / HALLOUMI et al.; Republic of Cyprus v EUIPO;** Judgment of 13 July 2018; EU:T:2018:481; Language of the case: EN

EUTM application	Earlier trade mark
	<p style="text-align: center;"><b>HALLOUMI</b></p>

The applicant sought to register the figurative mark above as an EUTM for goods in Class 29. An opposition based on, inter alia, the earlier UK certification mark **HALLOUMI**, registered for goods in Class 29, was filed pursuant to Article 8(1)(b) EUTMR and Article 8(5) EUTMR. The OD dismissed the opposition and the opponent appealed. The Board of Appeal (BoA) dismissed the opponent’s appeal insofar as it found that there was no likelihood of confusion between the earlier mark and the contested mark. It took the view that the inherent distinctive character of the term ‘halloumi’ was weak due to its descriptive character. Since the word mark preceded all the other trade marks, it is, to the relevant public, descriptive of the characteristics and composition of the product. The opponent appealed to the General Court (GC), relying on a single plea in law: infringement of Article 8(1)(b) EUTMR. **Relevant public.** Since the earlier mark is a UK mark, the relevant public consists of average UK consumers, who are reasonably observant and circumspect, since the products covered are everyday consumer goods (para. 24). **Comparison of the goods.** The goods are identical (para. 24). **Comparison of the signs.** (i) The signs have a low degree of visual similarity, since they coincide only in the element ‘halloumi’, which is of secondary importance due to its place within the contested mark (para. 60). The relevant public will pay more attention to the element ‘cowboys’, which appears as the dominant element of the contested mark on account of its positioning in the upper part of the sign. Moreover, the presence of the central, figurative element consisting of a cowboy hat, which, as an image, illustrates the word ‘cowboys’, will reinforce the pre-eminence of that word (paras 50-51). (ii) The signs have a low degree of phonetic similarity. They only have the term ‘halloumi’ in common and, when the two words comprising the contested mark are pronounced, the degree of phonetic similarity of the signs is average. The presence of the word ‘cowboys’ in the contested mark, however, gives rise to a significant difference in the



pronunciation of the two signs. Furthermore, since consumers would abbreviate the pronunciation of the contested mark to that one word, the phonetic difference between the signs appears all the greater (para. 62). (iii) The signs are conceptually dissimilar as the term ‘cowboys’ is unconnected with the earlier mark and therefore introduces a significant conceptual difference. The presence of the term ‘halloumi’ does not constitute a significant element in conceptual terms. Indeed, it has not been established that the public would understand it as a reference to a certification process to which the user of the trade mark is subject. The relevant public will understand the term ‘cowboys’ as an indication of the commercial origin of the goods (paras 64-66). **Inherent distinctiveness.** Even if the word ‘halloumi’, registered as a national certification mark, has a certain degree of distinctiveness, this does not mean that it must be recognised as having distinctive character per se to a degree that would provide it with unconditional protection enabling opposition to any registration of a later mark including that term (para. 38). The evidence submitted, consisting in particular of data on sales volumes, promotion and marketing efforts, extracts from cookery magazines or press articles and various written statements, relates to ‘Halloumi’ cheese as a speciality cheese from Cyprus. However, it is not possible to link the term ‘halloumi’, used generically, to any certification mark, or even to a reference to a certified cheese (para. 40). The word ‘halloumi’ is directly understood by the United Kingdom public as describing the characteristics or even the origin of the goods, but not as an indication of its certified quality, not even as an indication of that quality (para. 41). Even if the distinguishing function of United Kingdom certification marks must be understood as the ability to distinguish one class of goods from another class of goods, in the light of the evidence adduced by the Republic of Cyprus, it has not been demonstrated that the earlier mark, as a United Kingdom certification mark, is capable of constituting an indication of the commercial origin of the goods in question. The existence of a likelihood of confusion on the specific grounds of Article 8(1)(b) EUTMR depends on that being demonstrated (para. 43). Due to its descriptive character, the earlier mark is distinctive only to a low degree (para. 45). **No LOC.** The mere identity between the goods and the similarity of the signs as a result of the common presence of the descriptive term ‘halloumi’ is not sufficient to create a likelihood of confusion, because of the weak distinctive character of the earlier mark and its descriptive meaning (para. 82).

**T-905/16; NUIT PRECIEUSE (fig.) / EAU PRECIEUSE; *Chefaro Ireland DAC v EUIPO*; Judgment of 12 September 2018; EU:T:2018:527; Language of the case: EN**

EUTM application	Earlier trade mark
NUIT PRECIEUSE	EAU PRECIEUSE

The IR holder applied for protection for the figurative sign above for the goods in Class 3. An invalidity application based on the earlier French word mark **EAU PRECIEUSE**, registered, inter alia, for goods in Class 3, was filed pursuant to Article 8(1)(b) and Article 8(5) EUTMR. The Cancellation Division (CD) upheld the application for a declaration of invalidity as it noted that the goods in question were identical and the signs were similar. The intervener appealed against the CD’s decision and the Board of Appeal (BoA) annulled the decision as it found that there was no likelihood of confusion (LOC). The applicant appealed to the General Court (GC), relying on a single plea in law: infringement of Article 8(1)(b) EUTMR. The GC dismissed the appeal as it found that there was no LOC. **Relevant public.** The relevant territory was France as the earlier right relied on was a French trade mark. The relevant public was the general public with an average level of attention for the goods in question in Class 3 except for *soap, dentifrices; incense; room*



fragrancing preparations; cosmetic preparations for baths; shampoos, shower gels, bubble baths; deodorants for personal use for which the level was probably low (not disputed) (paras 23-24). **Comparison of the goods.** The BoA noted that the goods in question were identical (not disputed) (paras 25-26). **Comparison of the signs.** The BoA took the view that neither of the signs contained any element more dominant than any other (not disputed) (paras 30-32). The first and second elements of each sign are intrinsically linked and will be perceived as a complete phrase read and understood in its entirety (para. 44). The BoA was right to find that, taken together, the elements ‘eau’ and ‘précieuse’ had a low inherent distinctive character for the goods *toilet water; scented water* (paras 46-47). The contested sign **NUIT PRÉCIEUSE** is not devoid of distinctive character for the goods in question, given that it does not have a descriptive meaning in relation to those goods or their characteristics (para. 48). The BoA did not indicate the exact degree of visual and phonetic similarity but its silence may be interpreted as meaning that the similarity is average (para. 55). Even though the element ‘précieuse’ is the longest word, that is offset by the fact that the shorter words, the elements ‘nuit’ and ‘eau’ respectively, are the first words of each sign (para. 57). It is the noun rather than the adjective that determines the conceptual perception of the signs, namely **EAU PRÉCIEUSE** and **NUIT PRÉCIEUSE**. The relevant public clearly perceives the meaning of each of the signs as a complete phrase containing a noun, ‘nuit’ and ‘eau’ respectively, with an identical qualifying adjective, namely the label ‘précieuse’. The BoA was justified in finding that the signs are conceptually different (paras 62-63). **LOC.** The BoA found that since, ‘seen as a whole, each of the signs will be easy to distinguish and will be individually memorable to the French public, even for those with a low level of attention’, there will be no LOC (para. 66). The similarities between the signs are limited to the presence of the laudatory adjective ‘précieuse’, which the relevant French public will not perceive individually but exclusively in the context of each of the marks taken as a whole (paras 72, 79). **Enhanced distinctiveness of the earlier mark.** The applicant merely alleges that, ‘it becomes quite apparent’ that the earlier mark has enhanced distinctiveness, without explaining the reasons why the contested decision was wrong in that regard. So, the applicant does not indicate how exactly the assessment of the evidence adduced before the BoA is incorrect and thus this part of the plea is inadmissible (paras 85-87).

♦[T-112/17](#); **NEW ORLEANS PELICANS (fig.) / Pelikan et al.; Pelikan Vertriebsgesellschaft mbH & Co. KG v EUIPO**; Judgment of 12 September 2018; EU:T:2018:528; Language of the case: EN

EUTM application	Earlier trade marks
	<p data-bbox="1018 1666 1118 1693">Pelikan</p>

The applicant sought to register the figurative mark above as an EUTM for goods and services in Classes 9, 16, 18, 25, 28 and 41. An opposition based on, inter alia, two earlier word marks, **Pelikan**; registered for, inter alia, goods and services in Classes 9, 16, 18, 25, 28 and 41 respectively, was filed pursuant to Article 8(1)(b) and Article 8(5) EUTMR. The Opposition Division (OD) upheld the opposition for all the contested goods and services, finding that the goods and services of the earlier word marks were identical and similar and



that the signs were similar. The Board of Appeal (BoA) upheld the applicant’s appeal due to the differences between the signs and the fact that the opponent had failed to submit a coherent line of argument as to why use of the mark applied for would take unfair advantage of, or be detrimental to, the distinctive character or repute of the earlier mark. The opponent appealed to the General Court (GC), relying on eight pleas in law, alleging, in the first seven: infringement of Article 8(1)(b) EUTMR and, in the final plea, infringement of Article 8(5) EUTMR. **Dominant elements.** The BoA did not distort the description of the dominant figurative element of the mark applied for when it described it as a bird and not as a pelican, as the BoA’s definition does not exclude the possibility that the bird could be perceived as a pelican, though it is not clear (paras 34-37). Furthermore, the BoA did not err when it held that the dominant verbal element ‘New Orleans’ would not be perceived by the EU public as an indication of the geographical origin of the goods and services (paras 41-43). **Phonetic dissimilarity.** The word ‘pelicans’ in the EUTM might not be pronounced, due to its secondary position, and, if it were, it would be pronounced at the end, after the words ‘New Orleans’. If it is pronounced the differences between the signs are such, considering, inter alia, the respective number of words, that they cannot be held to be similar (para. 52). **Conceptual dissimilarity.** The concept conveyed by the mark applied for differs from that expressed by the earlier marks since it refers to the words ‘New Orleans’ and to an ‘indefinable angry looking bird surrounded by wings and holding a basketball under his beak’ (para. 56). Furthermore, the presence, in a stylised form, of the name of a city in the United States together with an animal, reinforced as the case may be by an element referencing a sports team, such as a basketball, constitutes in itself a conceptual association capable of being recognised by the relevant public (para. 57). **Independent distinctive role.** The word element ‘pelicans’ does not play an independent distinctive role in the mark as it does not include the word ‘pelikan’, but rather the word ‘pelicans’, with the letter ‘c’ instead of ‘k’ and with a final ‘s’ to indicate the plural (para. 63). Furthermore, the element ‘pelicans’ is not dominant, playing only a secondary role in the overall impression conveyed by the mark (para. 64) and no arguments have been put forward to plead in favour of recognising an independent distinctive role to that specific secondary element in the case at issue (paras 64-66).

♦ [T-418/17](#); **Safari Club / WS Walk Safari (fig.)**; *Eduard Meier GmbH v EUIPO*; Judgment of 13 September 2018; EU:T:2018:540; Language of the case: EN

EUTM application	Earlier trade mark
Safari Club	

The applicant sought to register the word mark **Safari Club** as an EUTM for goods and services in, inter alia, Classes 18 and 25. An opposition based on the earlier Italian figurative mark above, registered for certain goods and services in Classes 18 and 25 was filed pursuant to Article 8(1)(b) EUTMR. The Opposition Division (OD) upheld the opposition and the applicant appealed. The Board of Appeal (BoA) dismissed the appeal. It found that, given the average degree of conceptual and phonetic similarity of the signs, their visually similarity, and the average level of attention of the relevant consumer, there was a likelihood of confusion (LOC) for all the goods concerned. The applicant filed an action before the General Court (GC), relying on a single plea in law: infringement of Article 8(1)(b) EUTMR. **Relevant public.** The relevant public is made up of the Italian general public with an average level of attention, given the nature of the goods (inexpensive







items purchased on a regular basis) (para. 21). **Comparison of the goods.** The goods are identical or similar to varying degrees (para. 21). **Dominant and distinctive element.** The element ‘WS’ of the earlier mark would be perceived as merely an abbreviation of the word element ‘walk safari’, and therefore, cannot constitute the distinctive and dominant element of that sign (para. 37). **Comparison of the signs.** (i) The signs are visually similar, at least to a low degree, insofar as the graphical representation of the earlier mark (a frame and a slightly stylised font) will not detract the relevant public’s attention from its word elements (para. 44). However, they are visually different regarding hunting-related goods, since the common word element ‘safari’ will be accorded less importance, given that it alludes to those goods. Accordingly, visual attention will be drawn to the other elements of the signs, inter alia, the element ‘walk’ of the earlier mark and the element ‘club’ of the contested mark, two completely different words (para. 45). (ii) The signs are phonetically similar, at least to an average degree, since three of their four syllables are identical, and since the element ‘WS’ of the earlier mark, being perceived as an abbreviation, would not be pronounced (para. 50). As regards hunting-related goods, the degree of similarity must be regarded as low, insofar as the common word element ‘safari’ alludes to those goods (para. 48). (iii) The signs are conceptually similar, since the common word ‘safari’ conveys an identical concept, despite the weak conceptual differences between the words ‘walk’ and ‘club’ (para. 53). However, as regards hunting-related goods, the common element ‘safari’ will have only weak distinctive character for the relevant public who will pay more attention to the differences between the signs, namely, the element ‘walk’ of the earlier mark, and the element ‘club’ of the contested mark, which have different semantic content (para. 54). **Likelihood of confusion.** There is no LOC for hunting-related goods: given the weak distinctive character of the common word element ‘safari’, the visual differences between the other elements will prevail in their overall impression (para. 65). Those visual differences are especially crucial, since the hunting-related goods are usually sold in self-service shops in which the consumer chooses the product him- or herself and must, accordingly, rely on his or her recollection of the mark applied to the product (para. 64).

♦[T-652/17](#); **Eddy’s Snackcompany / TEDDY et al.**; *Eddy’s Snack Company GmbH v EUIPO*; Judgment of 19 September 2018; EU:T:2018:564; Language of the case: DE. The applicant sought to register the word mark **Eddy’s Snackcompany** as an EUTM for goods in Classes 29 and 30. An opposition based on, inter alia, the earlier German word mark **TEDDY**, registered for goods in Class 30, was filed pursuant to Article 8(1)(b) EUTMR against registration of the EUTM application for the goods for which protection was sought in Class 30. The Opposition Division (OD) dismissed the opposition. It found that despite a certain visual and aural similarity between the signs, there was, because of the total difference between their meanings, no likelihood of confusion (LOC). The opponent filed an appeal. The Board of Appeal (BoA) upheld the appeal. It found that there was a LOC: the goods were in part dissimilar and in part similar to varying degrees, while the signs had at least an average degree of visual and aural similarity and, conceptually, did not differ to the point that it was easy for the target public to differentiate between them. The applicant appealed to the General Court (GC), relying on two pleas in law: (i) infringement of Article 8(1)(b) EUTMR and (ii) infringement of Article 95(1) EUTMR. **Infringement of Article 8(1)(b) EUTMR. Distinctive and dominant elements.** The BoA erred when it excluded from the comparison the elements ‘s’ and ‘Snackcompany’ of the EUTM application, which are in fact not negligible (paras 41-42). **Visual and aural similarity.** As a consequence of that, and contrary to what the BoA considered, the signs have only a low degree of visual and aural similarity (paras 49-50, 52). **Conceptual similarity.** The BoA’s reasoning concerning the conceptual comparison is also flawed. In fact, the signs are not conceptually similar as, first, the hypothesis that teddy bears could be given the name ‘Eddy’ is pure speculation; second, the concepts of ‘teddy bear’ and ‘company belonging to



Eddy that produces snacks’ are completely different; third, if ‘Snackcompany’ is not taken into account, the notions of ‘teddy bear’ and that of the abbreviation of the name Eduard are also different; and, fourth, if ‘Teddy’ were taken as the abbreviation of ‘Theodor’ by some of the public, this name is very different from the name Eduard (paras 55-59). **Likelihood of confusion.** For goods that are not identical but simply similar, the low degree of visual and aural similarity of the signs is not sufficient to give rise to LOC, without it even being necessary to rule on the question of whether the conceptual differences between the signs are capable of neutralising the visual and aural similarities. There is no LOC (paras 65-66).

♦[T-623/16](#); **MAIN AUTO WHEELS (fig.) / VW (fig.) et al.**; *Volkswagen AG v EUIPO*; Judgment of 19 September 2018; EU:T:2018:561; Language of the case: DE

EUTM application	Earlier trade mark
	

The applicant sought to register the figurative mark above as an EUTM for goods and services in Classes 12 and 35. An opposition based on, inter alia, the earlier figurative mark above, registered for goods and services in Classes 12 and 35, was filed pursuant to Article 8(1)(b) and Article 8(5) EUTMR. The Opposition Division (OD) dismissed the opposition. It found that there was no likelihood of confusion (LOC) as the signs had a very low degree of similarity and produced different overall impressions. Regarding Article 8(5) EUTMR, it held that the opponent had failed to prove unfair advantage. The opponent filed an appeal, which the Board of Appeal dismissed. It found that the signs were dissimilar and that therefore there was no need to compare the goods and services. Since the signs were dissimilar, the opposition also failed insofar as based on Article 8(5) EUTMR. The opponent appealed to the General Court (GC), relying on three pleas in law: (i) infringement of Article 8(1)(b) EUTMR, (ii) infringement of Article 8(5) EUTMR and (iii) infringement of Article 94(1) EUTMR. **Comparison of the signs. Visual comparison.** The signs produce a different overall impression from a visual perspective. Their backgrounds are a rectangle and a circle, respectively. The EUTM application has both graphic and verbal parts and not only a graphic part as in the earlier mark. The line motif of the EUTM application is different from that of the earlier mark. This is because the lines in the EUTM application go from bottom to top rather than from top to bottom, and have different points of contact with the surrounding circle. The respective line motifs differ even when the sign applied for is viewed upside down (paras 42-43). The description of the sign in the application is irrelevant (para. 40). **Phonetic comparison.** A phonetic comparison is possible only if the relevant public recognises the signs ‘v’ and ‘w’ in the earlier sign. In that case, ‘main auto wheels’ would have to be compared to ‘vw’ or ‘wv’, and the conclusion would be that the signs are not phonetically similar. If the relevant public recognised the letters ‘m’ and ‘a’ in the EUTM application, there would be no phonetic similarity between the signs either. The applicant’s argument that a phonetic comparison is not possible because the EUTM application is dominated by its figurative elements must be rejected (paras 48-49). **Conceptual comparison.** Since the earlier mark does not convey any meaning, a conceptual comparison is not possible. A line pattern is not a concept (paras 50-51).



♦ [T-266/17](#); **UROAKUT / UroCys (fig.) et al.**; *Kwizda Holding GmbH v EUIPO*; Judgment of 20 September 2018; EU:T:2018:569; Language of the case: DE

EUTM application	Earlier trade mark
UROAKUT	UroCys

The applicant sought to register the word mark **UROAKUT** as an EUTM for *food supplements and dietetic preparations; medical and veterinary preparations and articles* in Class 5. An opposition based on the earlier figurative mark above, registered for *dietary substances and food supplements for medical purposes, other than for the treatment or prevention of gout* in Class 5, was filed pursuant to Article 8(1)(b) EUTMR. The Opposition Division (OD) upheld the opposition. The applicant filed an appeal. The Board of Appeal (BoA) dismissed the appeal. It found, first, that the level of attention of the relevant public would be normal for the general public of Germany and Austria and high for medical and pharmaceutical specialists; second, that the goods were identical or highly similar, and third, that the signs at issue had an average degree of visual and phonetic similarity and a certain conceptual similarity. The BoA found therefore that there was likelihood of confusion (LOC). The applicant brought an action before the General Court (GC), relying on a single plea in law, alleging infringement of Article 8(1)(b) EUTMR. **Relevant public's level of attention.** The BoA wrongly held that part of the relevant public would only show an average level of attention when purchasing the goods at issue. Both pharmaceutical products and dietetic products or food supplements are goods intended to improve health and consequently, as the case-law has consistently held, the relevant public will show a high level of attention when purchasing them (paras 25-30). **Comparison of the goods.** It is not disputed that the goods are either identical or highly similar as the BoA rightly held. **Comparison of the signs.** The relevant public will understand that preparations and drugs having names beginning with the word element 'uro' are intended for the treatment of urinary tract diseases. Therefore, the public will perceive this element more as a reference to the purpose of the product than as an indication of its commercial origin. It is thus an element with a weak distinctive character (paras 43, 80). As the BoA rightly held, the signs have an average degree of visual and phonetic similarity and a certain conceptual similarity given their common initial element 'Uro', which refers to the field of urology (paras 42, 55-56, 60-63, 68-70). However, the visual, phonetic and conceptual differences relating to the additional elements 'akut' and 'cys' of the signs are not negligible in the impression of the signs for the relevant public, but compensate for the visual, phonetic and conceptual similarities which result solely from the presence of the common element 'uro' and the idea to which it refers, all the more so when the relevant public will show an increased level of attention (para. 81). The overall impression of the signs for the relevant consumers will be different. There is no LOC (para. 82).

♦ [T-668/17](#); **Eico / MAICO**; *Maico Holding GmbH v EUIPO*; Judgment of 20 September 2018; EU:T:2018:567; Language of the case: EN. The applicant sought to register the word mark **Eico** as an EUTM for goods in, inter alia, Class 11. An opposition based on the earlier EU word mark **MAICO**, registered for goods in, inter alia, Class 11, was filed pursuant to Article 8(1)(b) EUTMR regarding *apparatus for heating, refrigerating, drying, and ventilating*. The Opposition Division (OD) dismissed the opposition and the opponent filed an appeal. The Board of Appeal (BoA) dismissed the appeal. It found that there was no likelihood of confusion (LOC), insofar as the visual and phonetic differences between the signs



outweighed their similarities, given the high level of attention of the relevant public. The opponent filed an action before the General Court (GC), relying on a single plea in law: infringement of Article 8(1)(b) EUTMR. **Relevant public.** The relevant public consists of business customers and the general public in all the EU Member States, who, given the durable, expensive and technical nature of the goods, will display a high level of attention when purchasing them. The average consumer will purchase them only after careful examination, irrespective of the fact that they will use those goods regularly following their purchase and subsequent installation (paras 22, 25). **Comparison of the goods.** The goods are identical (para. 27). **Comparison of the signs.** (i) The signs are visually different, insofar as they are of different lengths and have different sequences of letters. The earlier mark has ‘m’ and ‘a’ situated at the beginning, while the contested mark has the single letter ‘e’ situated at the beginning (paras 32-33). (ii) The signs are phonetically different, as the presence of the letter ‘m’ at the beginning of the earlier mark **MAICO**, immediately followed by the letter ‘a’, creates the first syllable ‘mai’, which differs from the first syllable of the contested mark, irrespective of the language considered (paras 37, 39). (iii) The signs have no meaning, therefore no conceptual comparison can be made (para. 40). **Likelihood of confusion.** Bearing in mind the relevant public’s high level of attention, and despite the identity between the goods, the differences between the signs are sufficient for those signs to convey different overall impressions. There is no LOC (paras 44-45).

♦[T-328/17](#); **BBQLOUMI (fig.) / HALLOUMI et al.**; *Foundation for the Protection of the Traditional Cheese of Cyprus named Halloumi v EUIPO*; Judgment of 25 September 2018; EU:T:2018:594; Language of the case: EN

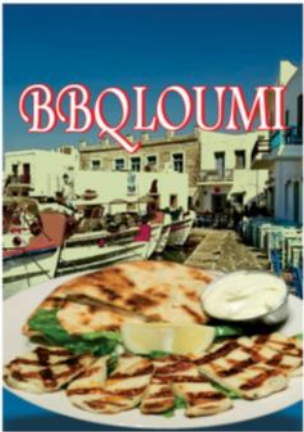
EUTM application	Earlier trade mark
	<p style="text-align: center;"><b>HALLOUMI</b></p>

The applicant sought to register the figurative mark above as an EUTM for goods and services in Classes 29, 30 and 43. An opposition based on the earlier EU collective word mark **HALLOUMI** registered for *cheeses* in Class 29, was filed pursuant to Article 8(1)(b) and Article 8(5) EUTMR. The Opposition Division (OD) dismissed the opposition and the opponent filed an appeal. The Board of Appeal (BoA) dismissed the appeal, finding there was no likelihood of confusion (LOC) given the weak distinctive character of the earlier mark, the low degree of visual similarity between the signs, the lack of phonetic and conceptual similarity and the varying degrees of similarity for some of the goods covered by the marks. The opponent filed an action with the General Court (GC), relying on a single plea in law: infringement of Article 8(1)(b) EUTMR. **Relevant public.** The relevant public is



the EU general public (para. 27). **Comparison of the goods.** The goods are identical (cheese) (para. 27). **Comparison of the signs.** Although the term ‘bbqloumi’ will attract the public’s attention, the public will also focus on the representation of the plate of food due to its presence in the foreground. The figurative representation is visually co-dominant and as regards the word element, more weight should be given to its initial part, namely ‘bbq’, rather than its final part ‘loumi’. Therefore, insofar as ‘loumi’ does not constitute a separate element in the word ‘bbqloumi’ and as it is the element on which the signs coincide, the visual similarity is low (para. 62). The five letters, ‘loumi’, appear in the earlier mark and in the word element of the contested mark, and this leads to a certain degree of phonetic similarity, which is low due to the final position of those letters in the contested mark and the different number of syllables (para. 64). Although the earlier mark conveys the concept of halloumi cheese, it cannot be ruled out that, to a certain extent, the contested mark conveys a similar concept. The BoA’s argument that the concept of ‘halloumi’ represents a cheese and not the commercial origin of the designated product or of the proprietor of the mark is ineffective, since it is relevant only at the stage of assessing the LOC and not at that of the conceptual comparison (para. 66). In fact, for the part of the public familiar with halloumi cheese, in this case a not insignificant part of the general public of the EU, the group of the last five letters ‘loumi’ can be understood as referring to the concept of halloumi cheese cooked or grilled on a barbecue (para. 67). The figurative elements, comprising a background showing a Mediterranean environment, introducing a link with the geographical position of Cyprus as a Mediterranean island, and a plate of food showing marks of grilling in the foreground, clearly reinforce the concept conveyed by the word element (para. 68). **Collective mark and distinctiveness.** The registration as a collective mark cannot per se give rise to a presumption that the mark has an average degree of distinctive character (para. 70). An analysis of the evidence as regards the perception of the earlier mark by the relevant public, including, inter alia, data relating to exports, sales, marketing and communication efforts, publications in various journals and works, showed that the word ‘halloumi’ denoted a particular type of cheese produced according to certain features and had done so for a long time, but did not identify it as belonging to anyone who marketed the product (para. 42). The evidence submitted was, furthermore, insufficient to establish intensive use as a trade mark designating cheeses (para. 70). **Likelihood of confusion.** There cannot be any LOC on the part of the relevant public since the existence of a visual, phonetic and conceptual similarity is not, for an earlier descriptive mark with a low degree of distinctiveness, sufficient to give rise to a presumption of LOC (para. 71).

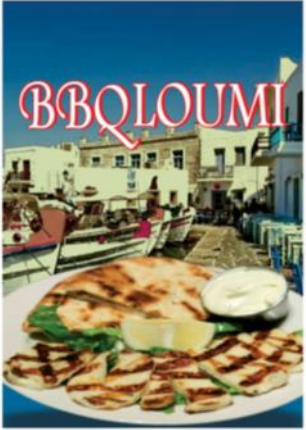

**T-384/17; BBQLOUMI / HALLOUMI et al.; Republic of Cyprus v EUIPO;** Judgment of 25 September 2018; EU:T:2018:593; Language of the case: EN

EUTM application	Earlier trade mark
	<p style="text-align: center;"><b>HALLOUMI</b></p>

The applicant sought to register the figurative mark above as an EUTM for goods and services in Classes 29, 30 and 43. An opposition based, inter alia, on the earlier UK certification word mark **HALLOUMI** registered for *cheese* in Class 29, was filed pursuant to Article 8(1)(b) and Article 8(5) EUTMR. The Opposition Division (OD) dismissed the opposition and the opponent filed an appeal. The Board of Appeal (BoA) dismissed the appeal, finding there was no likelihood of confusion (LOC) given the weak distinctive character of the earlier mark, the low degree of visual similarity between the signs, the lack of phonetic and conceptual similarity and the varying degrees of similarity for some of the goods covered by the marks. The opponent filed an action with the General Court (GC), relying on a single plea in law: infringement of Article 8(1)(b) EUTMR. **Relevant public.** The relevant public is the EU general public (para. 27). **Comparison of the goods.** The goods are identical (*cheese*). (para. 28). **Comparison of the signs.** Although the term ‘bbqloumi’ will attract the public’s attention, the public will also focus on the representation of the plate of food due to its presence in the foreground. The figurative representation is visually co-dominant and as regards the word element, more weight should be given to its initial part, namely ‘bbq’, rather than its final part ‘loumi’. Therefore, insofar as ‘loumi’ does not constitute a separate element in the word ‘bbqloumi’ and as it is the element on which the signs coincide, the visual similarity is low (para. 59). The five letters, ‘loumi’, appear in the earlier mark and in the word element of the contested mark, and this leads to a certain degree of phonetic similarity, which is low due to the final position of those letters in the contested mark and the different number of syllables (para. 61). Although the earlier mark conveys the concept of halloumi cheese, it cannot be ruled out that, to a certain extent, the contested mark conveys a similar concept (para. 63). In fact, for the part of the public familiar with halloumi cheese, in this case a not insignificant part of the general public of the EU, the group of the last five letters ‘loumi’ can be understood as referring to the concept of halloumi cheese cooked or grilled on a barbecue (para. 64). The figurative elements, comprising a background showing a Mediterranean environment, introducing a link with the geographical position of Cyprus as a Mediterranean island, and a plate of food showing marks of grilling in the foreground, clearly reinforce the concept conveyed by the word element (para. 65). **Certification mark and distinctiveness.** Even if it is appropriate to accord the word ‘halloumi’, registered as a national certification mark, a certain distinctiveness, that does not mean that it must be accorded an intrinsic distinctive



character of such a level that would provide it with unconditional protection enabling opposition to any registration of a later mark including that term (para. 43). It has not been demonstrated that the earlier mark, as a certification mark in the United Kingdom, would be capable of constituting an indication of the commercial origin of the goods in question. The existence of LOC on the specific conditions of Article 8(1)(b) EUTMR depends on this being demonstrated (para. 47). The earlier mark has a weak distinctive character due to its descriptive meaning (para. 49). The evidence, consisting of advertising material attached to various statements, articles and official records, and recipes, was insufficient to prove intensive use of the earlier mark in order to designate ‘cheeses’ in the United Kingdom and did no more than note the use of the word ‘halloumi’ as the generic name of a speciality cheese from Cyprus (para. 72). **Likelihood of confusion.** There cannot be any LOC on the part of the relevant public since the existence of a visual, phonetic and conceptual similarity is not, for an earlier descriptive mark with a low degree of distinctiveness, sufficient to give rise to a presumption of LOC (para. 71).

♦ **T-70/17; NorthSeaGrid (fig.) / nationalgrid (fig.) et al.; TenneT Holding BV v EUIPO;** Judgment of 27 September 2018; EU:T:2018:611; Language of the case: EN

EUTM application	Earlier trade marks
	

The applicant sought to register the figurative mark above as an EUTM for goods and services in Classes 4, 35 and 37 to 39. An opposition based on, inter alia, the two earlier EU trade marks above, registered for goods and services in Classes 1, 35 and 37 to 39, was filed pursuant to Article 46 EUTMR. The Opposition Division (OD) dismissed the opposition. The opponent filed an appeal. The Board of Appeal (BoA) partially upheld the appeal, namely for the goods and services for which protection was sought with the exception of the services *negotiation and settlement of commercial transactions for third parties relating to the delivery of electricity* in Class 35. It found that, with the exception of the latter services in Class 35, which were directed solely at business users, there would be a likelihood of confusion (LOC) for all the goods and services for which protection was sought. It also found, insofar as Article 8(5) was concerned, that it had not been proved that use of the mark applied for would take unfair advantage of, or be detrimental to, the earlier trade mark’s distinctive character or repute. The applicant filed an action with the General Court (GC), relying on two pleas in law: (i) infringement of Article 8(1)(b) EUTMR and (ii) infringement of Article 8(5) EUTMR. **Scope of the action.** Even though the applicant asked the court to annul the contested BoA decision without providing further clarification, it stated before the court that the action did not concern the part of that decision admitting certain services in Class 35 for registration (paras 25-26). It must furthermore be understood from the replies given by the applicant to the questions of the court that the applicant withdrew its second plea in law, alleging infringement of Article 8(5) (paras 30-31). **Relevant territory, relevant public and the latter’s level of attention.** As the earlier



marks are EU trade marks, the relevant territory is that of the European Union (para. 43). The relevant public includes both the general public and professionals. The applicant cannot validly rely on the fact that its circle of clients consists solely of professionals, since it is the description of the goods and services covered by the marks at issue, and not the goods and services actually marketed under those marks, that must be taken into account, and it is not apparent from the description of the goods and services that they are intended for professionals only (paras 50-54). Given, however, the sophisticated nature of the goods and services in question, the general public's level of attention is likely to be slightly higher than average (para. 59). **Comparison of the goods and services.** It is not disputed that the goods and services are identical (para. 42). **Comparison of the signs.** The overall impression conveyed to the relevant public by the mark applied for and the earlier marks is not dominated by any one of their respective components. In addition, none of the elements comprising the marks is negligible for the relevant public (paras 102, 117). The signs are visually similar to a low degree. The similarities, resulting from the presence of the common element 'grid' and the initial letter 'n', as well as the colour blue in the figurative signs at issue, are not totally offset by their differences (paras 123-125). The signs are also phonetically similar only to a low degree, due to their different number of syllables and the difference in pronunciation of their first parts, namely 'national' and 'northsea', respectively (paras 128-130). Conceptually, the signs are similar to a low degree for the English-speaking part of the relevant public, who will perceive the identical meaning of the common element 'grid' as a system of wires through which electricity is connected to different power stations across a region. For the non-English-speaking public it cannot be concluded that there is a conceptual similarity between the signs (paras 135-136, 142). In an overall comparison, the signs at issue are similar to a low degree for the English-speaking public, as they have a low degree of similarity for the visual, phonetic and conceptual aspects, while for the non-English-speaking public they have a low degree of visual and phonetic similarity and are conceptually different (paras 143-144). **Global assessment of the likelihood of confusion.** As regards the English-speaking public, despite the identity between the goods and services, the visual, phonetic and conceptual similarities of the signs are not sufficient to give rise to LOC for that part of the relevant public, which as mentioned above has a higher than average level of attention. That part of the public will view the common element 'grid' as descriptive, will identify the marked differences between the elements 'northsea' and 'national' and will note the figurative element of the mark applied for as reinforcing the message conveyed by the element 'northsea' (para. 146). As regards the non-English-speaking public, which also shows a high level of attention and takes time to study the marks, the differences between their respective initial parts counteract the presence of the common element 'grid', which is shorter and placed at the end of the marks. It is the element 'northsea' that will leave a particular impression on this part of the public, as it has a normal distinctive character, unlike the element 'national', which is only distinctive to a low degree. LOC does not exist here either (paras 147-149). The BoA therefore acted correctly in excluding LOC on the part of the English-speaking general public, but erred in finding that there was LOC on the part of the non-English general public (paras 150-151).



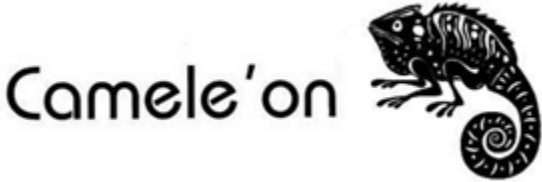

**T-472/17; Camele'on (fig.) / CHAMELEON; Wilhelm Sihh jr. GmbH & Co. KG v EUIPO;** Judgment of 27 September 2018; EU:T:2018:613; Language of the case: EN

EUTM application	Earlier trade mark
	<p>CHAMELEON</p>

The applicant sought to register the figurative mark above as an EUTM for, inter alia, goods and services in Classes 9 and 42. An opposition based on two earlier word marks **CHAMELEON** registered for *head ends for cable networks, namely apparatus for receiving, processing, converting, amplifying and transmitting signals; parts of the aforesaid goods; accessories or fittings for the aforesaid goods, as far as included in this class in Class 9*, was filed pursuant to Article 8(1) EUTMR against those goods and services. The Opposition Division (OD) partially upheld the opposition, but rejected it for the contested mark's *computer software packages and computer software for configuring technical and commercial data; software packages for computer-assisted production and/or sales in Class 9 and the services in Class 42*. The opponent appealed. The Board of Appeal (BoA) dismissed the appeal finding that the goods at issue in Class 9 and the contested services in Class 42 were dissimilar to the opponent's goods. The opponent filed an action before the General Court (GC), relying on a single plea in law: infringement of Article 8(1)(b) EUTMR. **Comparison of the goods and services.** It is not disputed that the contested *computer software* is different from *head ends for cable networks* in Class 9 of the earlier marks (para. 25). As regards the contested *computer software* and the earlier marks' *parts, accessories or fittings of head ends for cable networks* in Class 9, those goods are not identical or similar. The opponent failed to prove that configuration and operating software is an integral part of *head ends for cable networks* and it has emphasised itself that such software can be sold separately from *head ends for cable networks*. When the terms *parts* and *accessories or fittings* relate to numerous and complex goods, as is the case here, then they are vaguely defined terms. If the opponent wanted to ensure that the earlier marks were also registered for configuration and operating software for head ends for cable networks, it should have made it clear when it applied to register its trade marks. The applicant cannot gain from the vague wording of the goods covered by its marks (paras 28-30). The services at issue in Class 42 and the earlier marks' goods in Class 9 differ as regards their nature and intended purpose as the services relate to research, development and contribution of production, dissemination and application of scientific and technical knowledge whereas the earlier marks' goods are intended to perform a specific technical operation. Moreover, the earlier marks' *head ends for cable networks* and their *parts or fittings or accessories* belong to the field of telecommunications, whereas the contested services in Class 42 belong to the field of information technology. Furthermore, the opponent has not adduced any evidence capable of calling into question the finding that the contested services in Class 42 and the earlier marks' goods were usually supplied through different distribution channels (para. 38). The opponent's claim that *head ends for cable networks* are themselves computers and thus similar to the contested *computer services* in Class 42, cannot be accepted. The fact that *head ends for cable networks* may perform certain functions also carried out by computers is not sufficient to treat such apparatus like computers, the latter having much more complex and varied uses (para. 40).





♦ **T-150/17; FLÜGEL / ... VERLEIHT FLÜGEL et al.**; *Asolo Ltd v EUIPO*; Judgment of 4 October 2018; EU:T:2018:641; Language of the case: EN. The predecessor in title of the EUTM proprietor registered the word mark **FLÜGEL** as an EUTM for *beers; mineral and aerated waters and other non-alcoholic drinks; fruit drinks and fruit juices; syrups and other preparations for the preparation of drinks* in Class 32 and *alcoholic drinks (except beers)* in Class 33. An invalidity application was filed pursuant to Article 60(1)(a) EUTMR in conjunction with Article 8(1)(b) and Article 8(5) EUTMR. It was based on, inter alia, the earlier Austrian word mark **...VERLEIHT FLÜGEL** for *energy drinks* in Class 32. The Cancellation Division (CD) upheld the invalidity application in its entirety. In light of the repute of the earlier mark **...VERLEIHT FLÜGEL** and considering the possibility that the proprietor of the contested mark could take unfair advantage of that earlier mark, the CD accepted the request for a declaration of invalidity insofar as based on Article 60(1)(a) EUTMR in conjunction with Article 8(5) EUTMR. Furthermore, although the invalidity applicant was aware of the existence of the contested mark, it had not been demonstrated that the invalidity applicant had acquiesced in its use in Austria and been aware of it during the relevant period in this case, namely from 5 December 2006 to 5 December 2011. The proprietor filed an appeal, which the Board of Appeal (BoA) dismissed. However, the BoA did not assess Article 60(1)(a) EUTMR in conjunction with Article 8(5) EUTMR, since it found that there was a likelihood of confusion (LOC) with the earlier mark **...VERLEIHT FLÜGEL** on the basis of Article 8(1)(b) EUTMR. Therefore, it annulled point 2 of the operative part of the CD decision to the extent that examination under Article 8(5) EUTMR was not necessary. The BoA considered that the signs were similar to an average degree and the earlier mark's *energy drinks* were in part identical and in part similar to an average degree to all the goods of the contested mark. It also found that the evidence submitted by the proprietor was not sufficient to conclude that there had been acquiescence on the part of the invalidity applicant. The proprietor appealed to the General Court (GC), relying on two pleas in law: (i) infringement of Article 61(2) EUTMR and (ii) infringement of Article 60(1)(a) EUTMR in conjunction with Article 8(1)(b) EUTMR. **Scope of the contested decision.** By basing the invalidity of the contested mark on a ground different from that favoured by the Cancellation Division, the BoA merely substituted its own assessment for that of the Cancellation Division, thus exercising its powers under Article 71 EUTMR (para. 24). **Acquiescence.** The BoA rightly held, on the basis of all the information in the file, that the evidence adduced by the proprietor (before both the CD and the BoA) concerning the invalidity applicant's actual knowledge of the use of the contested mark in Austria was insufficient for the purposes of establishing that there had been acquiescence in that use within the meaning of Article 61(2) EUTMR. That is to say that the proprietor of the earlier mark had actually (and not just potentially) been aware of the use of the contested mark (paras 41-51). **Comparison of the goods.** To consider that alcoholic and non-alcoholic drinks are similar just because they are generally mixed, consumed or marketed together, when they are not intended to be consumed in either the same circumstances or the same state of mind or, as the case may be, by the same consumers, would put a large number of goods that can be described as 'drinks' into one and the same category for the purposes of the application of Article 8(1)(b) EUTMR. Therefore, it cannot be considered that an alcoholic drink and an energy drink are similar merely because they can be mixed, consumed or marketed together, given that the nature, intended purpose and use of those goods differ, based on the presence or absence of alcohol in their composition. Furthermore, the undertakings that market alcoholic drinks premixed with a non-alcoholic ingredient do not sell that ingredient separately and under the same or a similar mark as the premixed alcoholic drink at issue (paras 80-81). The average Austrian consumer is used to and aware of the distinction between alcoholic and non-alcoholic drinks, which is, moreover, necessary, since some consumers do not wish to, or even



cannot, consume alcohol (para. 83). The findings of the European Union judicature in previous cases on the relevant public's perception of drinks according to their alcohol content are undoubtedly valid in a context such as that of the present case. Although in some instances the Court might have acknowledged, in circumstances that were not identical to those of the present case, a low degree of similarity between alcoholic drinks and non-alcoholic drinks, that cannot be held to be sufficient to challenge the finding here that the conflicting goods are not similar (paras 84-85). The goods for which protection is sought in Class 33, *alcoholic beverages (except beers) and alcoholic essences; alcoholic extracts; fruits extracts (alcoholic)* are not similar to the earlier mark's *energy drinks*. Consequently, there is no LOC between the marks as regards the goods in Class 33. The contested decision must therefore be partially annulled.

**T-820/17; Alfrisa (fig.) / Frinsa F (fig.); Frinsa del Noroeste, S.A v EUIPO**; Judgment of 4 October 2018; EU:T:2018:647; Language of the case: ES



EUTM application	Earlier trade mark
	

The applicant sought to register the figurative mark above as an EUTM for goods and services in Classes 29 and 35. An opposition based on the earlier EU figurative mark above registered for goods in Class 29 was filed pursuant to Article 8(1)(b) EUTMR. The Opposition Division (OD) dismissed the opposition. It found that there was no likelihood of confusion (LOC). The opponent filed an appeal. The Board of Appeal (BoA) dismissed the appeal and confirmed the OD's findings. The opponent filed an action with the General Court (GC), relying primarily on the infringement of Article 8(1)(b) EUTMR. **Relevant public.** The goods target not only the general public but also professional clients. The examination focused on the perception of the general public as this public will be less attentive than the professional public (paras 30-31). **Comparison of the goods and services.** The goods and services are in part identical, in part similar to varying degrees, and in part different (para. 39) **Comparison of the signs.** The GC confirms that the common sequences of letters in the conflicting signs lack any semantic content or graphic features that could make them identifiable. Therefore, they cannot counteract the visual and phonetic differences between the signs (para. 44). **Distinctiveness of the earlier mark.** The extracts submitted and duly assessed by the BoA are insufficient to prove that the earlier trade mark was well known or had a reputation in the EU (para. 55). The alleged reputation of the undertaking is not to be confused with — and does not necessarily entail — the reputation of the earlier mark per se. In any event, the alleged reputation covers only Spain and not the whole of the EU (para. 57). It is not for the Office to search the website of the undertaking in order to find relevant data regarding the reputation of the earlier mark (para. 63). **Family of marks.** The existence of other marks containing the word 'frinsa' was alleged for the first time before the BoA (para. 65). However, no proof of use of said marks was adduced (para. 68). Furthermore, the opposition was based solely on the earlier mark and not on the alleged 'whole family' of marks (para. 70). **No likelihood of confusion.** Given the important visual and phonetic differences, and since the reputation of the earlier



mark was not duly proven, the low similarities between the signs are not sufficient to establish LOC.



♦**T-581/17; DEVICE OF FOUR CROSSING LINES (fig.) / DEVICE OF FOUR CROSSING LINES (fig.) et al.**; *Asics Corporation v EUIPO*; Judgment 16 October 2018; EU:T:2018:685; Language of the case: EN

EUTM application	Earlier trade mark
	

The applicant sought to register the figurative mark above as an EUTM for goods in Classes 18, 24 and 25. An opposition based on the earlier EU figurative mark above (for goods in Class 18) and an earlier Spanish figurative mark (for goods in Class 25) was filed pursuant to Article 8(1)(b) and Article 8(5) EUTMR. The Opposition Division (OD) dismissed the opposition, so the opponent filed an appeal. The Board of Appeal (BoA) dismissed the appeal, finding that the signs gave an overall different impression. It added that, as the signs were purely figurative, no phonetic comparison was possible and that the conceptual comparison remained neutral. The opponent filed an action before the General Court (GC), relying on five pleas in law: (i) infringement of Article 95(1) EUTMR, as the BoA committed a manifest error in the assessment of the facts and an infringement of essential procedural requirements during the comparison of the signs, (ii) infringement of the obligation of the BoA to review the legality of the OD’s decision, (iii) infringement of Article 94 EUTMR as the BoA infringed its obligation to state reasons, (iv) infringement of Article 8(1)(b) EUTMR, and (v) infringement of Article 8(5) EUTMR. **Relevant public and comparison of goods.** The relevant public consists of consumers in the EU (para. 38) and the goods are identical. **Comparison of the signs.** Even if the consumer does not recall details such as the size or thickness of the lines, the overall impression between the thick lines and curves forming a letter ‘x’ superimposed on a character “ on the one hand, and the thin straight lines that can be perceived as the number sign, ‘#’, inclined backwards to 45 degrees on the other, is so different that the consumer will not make a connection between the signs solely on the basis that they are both composed of parallel lines crossing two other, longer lines (para. 46). The overall impression given by the marks was different, and therefore, there is no visual similarity (para. 47). The signs are figurative marks without any word elements, therefore, it is not possible to compare the signs phonetically. The conceptual comparison remains ‘neutral’, since none of the graphic forms have a conceptual content (para. 48). **No LOC.** Given the lack of similarity between the signs, there is no LOC (paras 53-54).



♦[T-261/17](#); **SALOSPIR 500 mg (fig.) / Aspirin et al.**; *Bayer AG v EUIPO*; Judgment of 24 October 2018; EU:T:2018:710; Language of the case: EN



EUTM application	Earlier rights
	<p data-bbox="981 450 1155 528"><b>Aspirin</b> <b>Aspirin</b></p> 

The applicant sought to register the mark above as an EUTM for goods in Class 5 (*pharmaceuticals*). An opposition was filed pursuant to Article 8(1)(b) EUTMR, Article 8(4) EUTMR (§4(2) German law) and Article 8(5) EUTMR. It was based on the earlier German figurative mark **Aspirin** (above), the earlier German word mark **Aspirin**, the earlier EU figurative trade marks (above), and the non-registered sign **ASPIRIN** (packaging) in Germany. The Opposition Division (OD) dismissed the opposition, so the opponent appealed. The Board of Appeal (BoA) dismissed the appeal. It held that the contested mark was different from the earlier German marks and from the earlier EU figurative marks, and that the opponent had not proved that German law granted protection to the non-registered sign. The opponent filed an action before the General Court (GC), relying on three pleas in law: (i) infringement of Article 8(1)(b) EUTMR, (ii) infringement of Article 8(5) EUTMR, and (iii) infringement of Article 8(4) EUTMR. **Earlier EU figurative marks. Relevant public and comparison of goods.** The relevant public is the EU general public and professionals in the field of medicine and pharmacy, with a high degree of attentiveness with regard to pharmaceuticals. The goods are identical (*pharmaceuticals*) (para. 32). **Dominant and distinctive elements.** Taking account of its large size and its central position on a white background, the word element ‘salospir’ is dominant. Pharmaceuticals issued without prescription are purchased in a pharmacy and the purchaser, as a general rule, will say their name. Moreover, the word element ‘salospir’ has no meaning and, therefore, has an inherent distinctive character (paras 38-39). It is well known that the combination of green and white is commonplace in the pharmaceutical sector and the intervener had filed evidence in support of that argument (para. 42). The white and green colour combination does not have independent distinctive character in the contested mark as it is commonplace in the pharmaceutical sector (para. 47) and it is not identical to the earlier marks (paras 45, 56, 75). **Probative value of the surveys.** The survey on neutralised packaging does not concern the contested mark and is thus not capable of demonstrating the independent distinctive character of the combination and configuration of the white and green colours (para. 55). Regarding the Salospir survey, the legal principles applicable to the assessment of LOC between the signs constitute a point of law (para. 59). Furthermore, the neutralised packaging survey and the Salospir survey were not carried out in the objective circumstances in which the marks are present, or may be present, on the market. Firstly, a purchaser does not just look at the packaging, and neutralised packaging is not present as such on the market. Secondly, the surveys were conducted at the homes of the survey participants, therefore not under the usual conditions that prevail when purchases of



these goods are made (in pharmacies). Thirdly, the SALOSPIR product is not traded in Germany where the surveys took place (para. 65). Finally, participants were not shown several images, but only one single image with leading questions being asked inducing participants to think about the over-the-counter pharmaceuticals they knew in Germany (paras 68-69). **Comparison of the signs.** As regards earlier EU figurative marks, the dominant and distinctive word element ‘salospir’ has no counterpart in the earlier marks. The visual differences outweigh the common combination of white and green (paras 74-76). Since the earlier EU figurative marks do not contain any word element that could be pronounced or understood, no phonetic or conceptual comparison is possible (para. 78). The overall impression is different (para. 79). **Earlier German trade marks.** The relevant public is the German public, composed of professionals and of end consumers with a high degree of attention (para. 87). The goods covered are identical (para. 88). The signs are visually different, as the word ‘salospir’ differs from the word ‘aspirin’ in the beginning, the middle and the end, and the contested mark contains figurative elements that are absent from the earlier marks (paras 89, 93). The signs are also phonetically different, since the syllables, sequences of vowels and overall phonetic impressions are different (para. 90). Conceptually, no comparison is possible, since the words ‘salospir’ and ‘aspirin’ have no meaning in German (para. 91). The signs are dissimilar overall (para. 98).

♦[T-63/17](#); **Bingo VIVA! Slots (fig.) / vive bingo (fig.); Grupo Orenes, S.L. v EUIPO**; Judgment of 24 October 2018; EU:T:2018:716; Language of the case: ES



EUTM application	Earlier trade mark
	

The applicant sought to register the figurative mark above as an EUTM for *online video game services related to free games* in Class 41. An opposition based on the earlier figurative EUTM above, registered for services in Classes 28, 35, 36, 38 and 41, was filed pursuant to Article 8(1)(b) EUTMR. The Opposition Division (OD) dismissed the opposition. The opponent filed an appeal. The Board of Appeal (BoA) dismissed the appeal. It found that the services were identical and the signs had a very low visual similarity and an average phonetical and conceptual similarity. It considered that given the nature of the services in question, the visual aspect should be favoured in the assessment and consequently, a likelihood of confusion (LOC) between the signs had to be excluded. The opponent filed an action with the General Court (GC), relying on two pleas in law: (i) infringement of Article 94 EUTMR and ii) infringement of Article 8(1)(b) EUTMR. **Article 8(1)(b) EUTMR. Relevant public.** The relevant public is the general public of the EU, whose level of attention is average (not disputed) (paras 30-31). **Comparison of services.** The contested services are identical to some services of the earlier mark in Class 41. **Comparison of signs.** The GC confirms that the distinctive elements of the earlier mark are the figurative element and the verbal element ‘vive’, whereas in the mark applied for, the public will pay attention mainly to the figurative part of the sign and the verbal element ‘VIVA’. ‘Bingo’ and ‘Slots’ are descriptive in relation to the services (paras 45-51). The signs have a very low visual similarity as they have a different structure, image and overall composition. The relevant public will not focus solely on the verbal elements ‘vive’ and ‘viva’, but also on the figurative parts of the conflicting signs, which



differ in every respect (para. 57). The verbal elements ‘bingo’ and ‘slots’ are descriptive and consequently have a limited phonetic weight. Following the order in which the words appear, the mark applied for could be pronounced as ‘bingo viva! Slots’. The BoA finding that the signs are phonetically similar only to an average degree is not questioned by the GC (paras 62-64). The signs are conceptually similar to an average degree, without this finding being contested by the parties (paras 65-66). **Overall assessment.** The consumers of the contested signs will rely basically on their visual appearance (para. 72). The way the internet and search engines work does not exclude the possibility of making a comparison between the figurative elements (para. 74). The fact that access to these services is initially free cannot exclude the public carrying out a comparative process between different offers, since this does not exclude the service from offering paid content or requiring a financial investment at a later stage (para. 73). Although the services covered by the marks are identical, the importance of the visual differences between the signs provides sufficient grounds for considering that there is no LOC (para. 77).

♦[T-339/17](#); **SEVENOAK (fig.) / 7seven (fig.)**; *Shenzhen Jiayz Photo Industrial Ltd v EUIPO*; Judgment of 21 November 2018; EU:T:2018:815; Language of the case: EN

EUTM application	Earlier trade mark
	

The applicant sought to register the figurative mark above as an EUTM for, inter alia, *optical lenses* and *bags adapted for carrying photographic apparatus* in Class 9. An opposition based on the earlier figurative mark above, registered for *optical apparatus and instruments* and *cases for photographic apparatus, for glasses*, inter alia, in Class 9 was filed pursuant to Article 8(1)(b) EUTMR. The Opposition Division (OD) dismissed the opposition finding that, notwithstanding the identity between the goods, there was no likelihood of confusion (LOC) because, overall, the observant consumer would notice the differences between the signs at issue. The opponent filed an appeal. The Board of Appeal (BoA) upheld the appeal, finding that, given the similarities between the marks and the identity between the goods concerned and because of the principle of the interdependence of factors, there was a LOC, in particular for English-speaking consumers, even when paying a high level of attention for goods in the optics sector. The applicant appealed to the General Court (GC), relying on one plea in law: infringement of Article 8(1)(b) EUTMR. **Comparison of the goods.** The goods are identical and this is not disputed. **The relevant public and its level of attention.** The goods are directed not only at professionals but also at the general public who have an interest in photography — whose level of attention is deemed to be average (paras 43-44). **Comparison of the signs.** Visually, although the signs share the word element ‘seven’, they differ in several respects: first, while the mark applied for is represented in eight grey letters with a slim, vertical appearance that are not joined together, the earlier mark is composed of six bold letters with black outlines, white on the inside, aligned at the bottom and interconnected with regard to the element ‘seven’; secondly, while the mark applied for is represented in upper-case letters, the earlier mark is represented in lower-case letters; and thirdly, the mark applied for does not include the number 7, which appears at the beginning of the earlier mark. However, it includes the letter ‘n’, which is much more stylised than the ‘n’ in the earlier mark, and the ending ‘oak’, which does not appear in the earlier mark. The marks are thus visually dissimilar, and not



similar to a certain degree, as wrongly held by the BoA (paras 73-79). The pronunciation of the common word element 'seven' can create a certain phonetic similarity between the marks, which is not offset by the presence of the letters 'o', 'a' and 'k' at the end of the mark applied for (para. 83). There is some conceptual similarity between the marks as regards the English-speaking public because the common word element 'seven' will be understood as referring to the concept of the number 7 (paras 86-87). Even though the purchase of the goods may be made on an oral recommendation, the marks will generally be perceived visually prior to purchase (para. 93) and the visual aspect plays a greater role in the assessment of the similarity between the marks. Therefore, the differences in the respective visual perception of the marks outweigh the similarities found at the phonetic and conceptual levels, so the relevant public will not have the impression that the marks are similar (para. 95). **Likelihood of confusion.** Insofar as the visual aspect plays a greater role in the assessment of the similarity between the marks, the differences in the respective visual perception of the marks outweigh the similarities found at the phonetic and conceptual levels, so that the relevant public would not have the impression that the marks are similar. Therefore, in the absence of a minimum degree of similarity, the principle of interdependence does not apply and there is no LOC between the marks (paras 101-103). It follows that the contested decision must be annulled (para. 106).

**T-546/17; Leshare / LEXWARE; Haufe-Lexware GmbH & Co. Kg v EUIPO**; Judgment of 15 November 2018; EU:T:2018:782; Language of the case: EN. The applicant sought to register the word mark **Leshare** as an EUTM for goods in Classes 9 and 35. An opposition based on the earlier EU word mark **LEXWARE**, registered for goods in Classes 9 and 35, was filed pursuant to Article 8(1)(b) EUTMR. The Opposition Division (OD) dismissed the opposition. It considered that, despite the identical nature of the goods and services, there was no likelihood of confusion (LOC). The opponent appealed but the Board of Appeal (BoA) dismissed the appeal, finding that the differences, particularly on a conceptual level, were sufficient to rule out LOC. The opponent filed an action before the General Court (GC), relying on a single plea in law: infringement of Article 8(1)(b) EUTMR. **Relevant public.** The relevant public is, principally, the English-speaking public and the public with a basic knowledge of English, since the use of English is very common in the area of electronics and information technology (para. 30). The level of attention of the target public for the goods in Class 9 is average, whereas for the services in Class 35, such as the *rental of advertising space*, the *rental of advertising time on communication media* or the *production of advertising films*, are directed at professionals with a higher degree of attention (para. 23). **Comparison of the signs.** (i) The relevant public might immediately split the contested mark into the familiar elements 'le' and 'share', whereas the earlier mark will be intuitively divided into 'lex' and 'ware'. This visual splitting-up will lessen the effect of the coincidence between both the first and the last letters of the signs (para. 48). The signs are all the more likely to be broken up because the goods and services are in the field of information technology and information services, in which the use of English is very common. The terms 'ware' and 'share' will only have an average, or even low, degree of visual similarity (para. 49). There is no analogy to the situation examined in the 'MULTIPHARMA' judgment, since here the common word elements cannot be grouped in a word that is common to those signs and that has its own meaning and which is closely linked to the goods. The signs are visually similar to an average degree (paras 52-53). (ii) Despite the same number of syllables and the identity of their beginnings and endings, the difference between the middle letters 'xw' and 'sh' is readily perceptible when the signs are spoken (para. 54). Therefore, their degree of phonetic similarity is, at most, average (para. 56). (iii) The sign **LEXWARE** will have a meaning that is immediately apparent to the relevant public, although that sign is, to a certain extent, descriptive of those goods and services. In addition, the presence of a prefix before the word 'ware' will be perceived as







natural, or even intentional, although the relevant public may not understand the precise meaning of the word 'lex' (para. 59). The sign **Leshare** is not only meaningless but will also, at first sight, appear strange and unusual for the relevant public. The signs must be considered conceptually dissimilar (para. 62). **No LOC**. There is no LOC, insofar as the conceptual differences between the signs can be grasped, not only by the relevant public whose level of attention is high, but also by the public whose level of attention is average. This difference can also counteract in the eyes of that public the low, or average, visual and phonetic similarity of the signs (paras 72-73).

♦ [T-78/18](#); **FERMIN / FERMIPAN et al.**; *AB Mauri Italy SpA v EUIPO*; Judgment of 22 November 2018; EU:T:2018:829; Language of the case: EN. The applicant sought to register the word mark **FERMIN** as an EUTM for goods in Classes 1 and 30. An opposition based on the earlier international and Benelux word mark **FERMIPAN**, registered for goods in the same classes, was filed pursuant to Article 8(1)(b) EUTMR. The Opposition Division (OD) partially upheld the opposition for *flour; yeast, yeast extracts, bread improvers; baking powder; sour dough, ferments for pastes, mixes for bakery products; bakery mixtures (ready-to-use bread mixes); yeast-based preparations for bread, pastries and pizza dough*, finding them identical or similar to *yeast*. The applicant filed an appeal and the Board of Appeal (BoA) upheld the appeal. It found that *mixes for bakery products; bakery mixtures (ready-to-use bread mixes); yeast-based preparations for pastries and pizza dough* were not similar to *yeast*. It also found that the goods were not similar to *chemicals and biochemical products for artisanal use for preparing and improving bakery and pastry products* in Class 1. The opponent appealed to the General Court (GC), relying on a single plea in law: infringement of Article 8(1)(b) EUTMR. (i) The contested goods and *yeast* in Class 30, which mainly includes food of plant origin, share the same distribution channels and are aimed at the same public. They also have a common purpose inasmuch as they are principally intended to be used for making bakery products (paras 31-32). The fact that the goods differ in their nature is not necessarily sufficient for them to be considered dissimilar (para. 36). There is no reason to treat *yeast-based preparations for bread* and *yeast-based preparations for pastry and pizza dough* differently, when these two categories of products have *yeast* as a key ingredient. The Office's argument that *yeast-based preparations for bread* did not fall within the scope of the appeal cannot be accepted: in the review that the BoA must undertake of the decisions taken by the Office at first instance, it is required to base its decisions on all the matters of fact and of law that the parties put forward either at first instance or in the appeal (para. 37). Therefore, these goods are similar. (ii) In the absence of any evidence adduced by the applicant, it cannot be concluded that *chemicals and biochemical products for artisanal use for preparing and improving bakery and pastry products* share the same distribution channels as the contested goods: the former are specifically described as being intended for professionals and are, moreover, in Class 1, which mainly includes chemicals used in industry, science and agriculture (para. 43). Moreover, it has not been established that the *chemicals and biochemical products for artisanal use for preparing and improving bakery and pastry products* and the contested goods are produced by the same manufacturers (para. 44). Therefore, and despite the common purpose invoked for *chemicals and biochemical products for artisanal use for preparing and improving bakery and pastry products* and the contested goods, there is no similarity between these goods (para. 45).



♦ [T-763/17](#); **welly (fig.) / Kelly's (fig.) et al.**; *Septona AVEE v EUIPO*; Judgment of 29 November 2018; EU:T:2018:861; Language of the case: EN

EUTM application	Earlier trade mark
	

The applicant sought to register the figurative mark above as an EUTM for *rice cakes; rice-based snack food; cereals; cereal bars; cereal-based snack food; muesli; cake dough; rusks; natural sweeteners* in Class 30. An opposition based, inter alia, on the earlier figurative mark above, registered, inter alia, for *extruded and pelletised or otherwise manufactured or processed tapioca, manioc, rice, maize, wheat or other cereal products for snacks; savoury biscuits; muesli bars, mainly consisting of nuts, dried fruits, processed cereal grains; chocolate and chocolate products; sauces* in Class 29, was filed pursuant to Article 8(1)(b) EUTMR. The Opposition Division (OD) dismissed the opposition finding that there was no likelihood of confusion (LOC). The opponent filed an appeal. The Board of Appeal (BoA) upheld the appeal finding that there was LOC as the goods at issue were identical, with the exception of *natural sweeteners*, which it held to be similar to a low degree; that the signs were similar to a higher than average degree visually and phonetically and to a limited degree as regards their conceptual content; and that the distinctiveness of the earlier mark was average while the relevant consumer's level of attention was lower than average. The applicant filed an action before the General Court (GC), relying on a single plea in law: infringement of Article 8(1)(b) EUTMR. **Relevant public.** The relevant public is composed of average consumers in the EU, which is not disputed (para. 25). For inexpensive everyday consumer goods generally sold in supermarkets such as those applied for, the relevant public will display a lower than average degree of attention (paras 31-32). **Comparison of the goods.** With the exception of *natural sweeteners*, the contested mark's goods are identical to those of the earlier mark, which is also undisputed (para. 35). The BoA correctly held that the earlier mark's *chocolate and chocolate products* are similar, albeit to a low degree, to *natural sweeteners* because in the preparation of cereal snacks, muffins and cakes, chocolate and chocolate products, such as chocolate chips, are often used to sweeten those preparations naturally (para. 39). **Comparison of the signs.** Although the colour combinations and the quadrilateral forms used in the backgrounds of the respective signs are quite common and the word elements are very similar in length and coincide in the letters 'e', 'l', 'l' and 'y', placed in the same order, this is not sufficient to conclude that the signs are visually similar to a higher than average degree. Due to the differences resulting from the shape of the labels, the white lines emphasising the upper and lower edges of Kelly's label, the different arrangement of the word elements (horizontally and diagonally, respectively) and of the different aspect of the letters and colour of the backgrounds, the signs at issue are held to be only slightly similar in visual terms and not similar to an above average degree as the BoA wrongly held (paras 46-55). Additionally, contrary to what the BoA found, the signs must be regarded as having only a low degree of phonetic similarity because the initial letters 'w' and 'k' are markedly different letters aurally (paras 61-62). Since the signs are conceptually different for many consumers and, for those consumers who do not know that the word 'kelly' (with an upper case 'k') is a name, and do not perceive any concept in the word 'welly', the conceptual comparison of the signs at issue is neutral (para. 71). **Likelihood of confusion.**



Contrary to what the BoA found, the signs, taken as a whole, only have a low degree of visual and phonetic similarity. Moreover, the signs are conceptually different for a large part of the relevant public, while for the remainder of that public the conceptual comparison between the signs is neutral. Therefore, the low degree of visual and phonetic similarity between the signs cannot be offset by the fact that most of the goods are identical. The single plea must therefore be upheld and the contested decision annulled (paras 80, 81, 87).

♦[T-638/16](#); **DARSTELLUNG EINES SCHUHES (fig.) / BALKENDARSTELLUNG AUF EINEM SCHUH (POSITIONSMARKE) et al.**; *Deichmann SE v EUIPO*; Judgment of 6 December 2018; EU:T:2018:883; Language of the case: DE

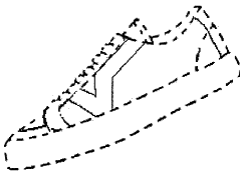
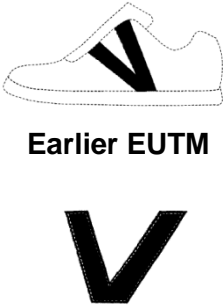
EUTM application	Earlier trade marks
	 <p style="text-align: center;"><b>Earlier EUTM</b></p> <p style="text-align: center;"><b>Earlier IR designating the EU</b></p>

The applicant sought to register the figurative mark above as an EUTM for *clothing, footwear, headgear, belts, gloves* in Class 25. An opposition based on the earlier position mark (EUTM) above, registered for *footwear* in Class 25, and on the earlier figurative mark above, registered for *clothing, footwear, headgear* (international registration (IR) designating the EU), was filed pursuant to Article 8(1)(b) EUTMR. The Opposition Division (OD) dismissed the opposition. The opponent filed an appeal. The Board of Appeal (BoA) dismissed the appeal. It found that the visual dissimilarities between the mark applied for and the earlier EUTM precluded any likelihood of confusion (LOC) between them. In addition, the extract in German from the CTM-Online (now eSearch Plus) database and the mention in the opposition form of the IR's goods did not constitute proof of the existence, validity and extent of protection of the mark. The opponent appealed to the General Court (GC), relying on two pleas in law: (i) infringement of Article 8(1)(b) EUTMR concerning the earlier EUTM; and (ii) infringement of Article 7(2) EUTMDR and Articles 8(1), (2) and (7) EUTMDR, of Article 189 EUTMR and of the principles of the protection of legitimate expectations and legal certainty and the prohibition of non-retroactivity concerning the earlier IR. **First plea (concerning the earlier EUTM). Relevant public.** It is not disputed that the goods at issue are intended for the general public, whose level of attention is of an average degree (para. 27). **Comparison of signs.** The fact that the EUTM application contains neither an indication that it refers to a position mark nor a description stating the positioning of the trade mark does not prevent, in principle, the mark applied for from being classified as a position mark (para. 35). However, the mark applied for here cannot be classified as such considering that dashed lines are not used exclusively in position marks, that the mark applied for does not only cover footwear and that the applicant did not indicate that it was meant to be a position mark nor did it provide a description of the mark specifying its positioning on the goods *footwear* (paras 37, 39, 40). This conclusion is not called into question by the BoA decision



04/12/2015, R 2345/2014-4, DEVICE OF A CROSS ON A SPORTS SHOE SIDE (FIG. MARK) where the mark applied for was limited solely to *sports shoes* and the question of whether the mark applied for was a position mark thus appeared differently (paras 41, 44). It is furthermore irrelevant to the lawfulness of the contested decision that, in Case T-68/16, concerning an action against the abovementioned decision of the BoA, the Office may have expressed a different opinion concerning whether it was bound by the classification of the mark as figurative by the applicant in the application form, since the legality of BoA decisions must be assessed solely on the basis of the EUTMR as interpreted by the EU Courts and not on the basis of previous decisions of the Office (para. 45). The parties in the latter case were not identical to those in this case and it appears that the applicant was not authorised to produce the document containing the response of 11 April 2016 submitted by the Office in Case T-68/16, which is thus inadmissible (paras 51-53). The signs differ visually from one another, in particular in their colour and the thickness of the lines, and in their shape, since the figure of the earlier mark can be divided into two parts, whereas the mark applied for shows three sections. The relevant public will perceive both marks as consisting of abstract lines and not as a letter ‘v’ (paras 56, 58, 65-68). Therefore, even assuming that the mark applied for constituted a ‘position mark’, the signs are visually dissimilar (para. 75). Furthermore, since the signs cannot be compared phonetically or conceptually, the BoA rightly held that there was no LOC between the mark applied for and the earlier EUTM (para. 76).

♦[T-274/17](#); **MONSTER DIP (fig.) / MONSTER ENERGY (fig.) et al.**; *Monster Energy Company v EUIPO*; Judgment of 13 December 2018; EU:T:2018:928; Language of the case: EN

EUTM application	Earlier rights
	 <p data-bbox="927 1453 1209 1514">MONSTER ENERGY MONSTER</p> <p data-bbox="770 1518 1361 1554">UK non-registered TM ‘MONSTER ENERGY’</p>



The applicant sought to register the figurative mark above as an EUTM for goods and services in Classes 2, 37 and 40. An opposition based on the EU word marks **MONSTER ENERGY** and **MONSTER**, the EU figurative mark (above) and the unregistered UK mark **MONSTER ENERGY**, inter alia, was filed pursuant to Article 8(1)(b) EUTMR, Article 8(4) EUTMR and Article 8(5) EUTMR. The Opposition Division (OD) dismissed the opposition. The opponent appealed, which the Board of Appeal (BoA) dismissed, finding that the goods and services were dissimilar. It stated that reputation had only been established for the earlier EU figurative mark **MONSTER ENERGY** and that it would only, therefore, take that earlier mark into account. It found that the marks were similar ‘to at least a certain extent’, but taking all the circumstances of the case into account, there was no link between the marks. The opponent filed an action before the General Court (GC), relying on five pleas in law: (i) the BoA wrongly held that the goods and services were different, (ii) the BoA wrongly rejected the existence of a conceptual similarity between the contested



mark and the earlier EU figurative mark **MONSTER ENERGY**, (iii) the BoA wrongly held that the relevant public would not establish a link between those marks, (iv) the BoA wrongly concluded that the distinctive character of the earlier marks was not undermined, (v) the BoA erred in failing to analyse the application of Article 8(4) EUTMR. **Relevant public.** The relevant public is composed of the general public with an average level of attention and professionals with a high level of attention (para. 27). **Comparison of the goods and services.** The goods in Class 16 of the earlier EU figurative mark **MONSTER ENERGY** and the contested mark's goods and services are generally not supplied or manufactured by the same undertakings, due to the different kinds of expertise needed, nor do they share the same distribution channels or points of sale. Moreover, they are not complementary in the sense that one is indispensable or important for providing the others (para. 41). Even in the rare event that the paint were used to decorate a vehicle, it could not be substituted for stickers or decals. Moreover, the goods *stickers, decals or transfers* in Class 16 cannot be regarded as 'substitutes' for the contested mark's *customised manufacture and prefabrication of coating preparations* services, nor do they share the same purposes (para. 45).

### 3. Other LOC related cases

♦ [T-151/17](#); **DEVICE OF A WINGED BULL (fig.) / DEVICE OF A GRIFFIN (fig.) et al.**; *Marriott Worldwide Corp. v EUIPO*; Judgment of 15 March 2018; EU:T:2018:144; Language of the case: EN

EUTM	Earlier trade mark
	

The intervener obtained the registration of the EU figurative trade mark above for the services in Class 43 *services for providing food and drink; catering and providing food and drink for cafes, hotels and restaurants*. The applicant filed an application for a declaration of invalidity of the contested mark against the abovementioned services pursuant to Article 60(1)(a) EUTMR read in conjunction with Article 8(1)(b) and Article 8(5) EUTMR, Articles 59(1)(b) and 60(2)(c) EUTMR. It was based on two earlier identical figurative marks above: the EU trade mark registered on 31 January 2010, No 8 458 259 and the United Kingdom trade mark registered on 30 April 2010, No 2 536 999 relating to the same services in Class 43 *services for providing food and drink; temporary accommodations; hotel services; restaurant, catering, bar and lounge services; resort and lodging services; provision of general purpose facilities for meetings, conferences and exhibitions; provision of banquet and social function facilities for special occasions; and reservation services for hotel accommodations*. The application for a declaration of invalidity was also based on the earlier copyright, designating the design of a griffin as depicted above, registered at the US Copyright Office on 19 March 2010, for which the applicant had obtained a user licence and claimed protection under United Kingdom legislation. The Cancellation Division (CD)



rejected the application in its entirety and the applicant appealed against the CD’s decision. The Board of Appeal (BoA) dismissed the appeal as it found that the signs at issue were visually and conceptually different and that it was not possible to compare them phonetically, since they were not pronounced; that the applicant had failed to demonstrate the existence of the alleged copyright. The applicant filed an action before the General Court (GC) relying on three pleas in law: (i) infringement of Article 95(1) EUTMR, (ii) infringement of Article 60(1)(a) EUTMR read in conjunction with Article 8(1)(b) EUTMR, (iii) infringement of Article 60(2)(c) EUTMR. The GC denied the infringement of Article 95(1) EUTMR (paras 17-23). **On the second plea in law.** The GC arrived at the following findings. **Visual comparison.** Both of the signs at issue feature a black-on-white silhouette of an animal-like creature viewed in profile and sitting in the same position, resting on their hind legs with their back straightened. Each of those figures has wings spread out towards the back and a tail which curves upwards. The wings, the body and the tail of the animals are depicted in similar proportions in the two signs (para. 36). The signs at issue differ in that one depicts the forward-facing head of a bull with horns and the other the head of an eagle aligned to the left. However, those differences are not such as to counteract the similarities set out before (para. 38). Those signs have at least a low degree of visual similarity, so the BoA was wrong (para. 39). **Phonetic comparison.** The BoA found that it is not possible to pronounce the signs at issue and that therefore a phonetic comparison is irrelevant (para. 40). **Conceptual comparison.** There is necessarily a conceptual similarity for the relevant public between the signs at issue insofar as they evoke an imaginary creature merging the characteristics of several animals (para. 42). Although the heads of the creatures are those of two different animals, namely a bull and an eagle, the wings, bodies and hind legs of each of the signs evoke very similar animals. The intervener acknowledges that the legs of the creature in the contested mark are those of a lion, and it is common ground between the parties that the griffin in the earlier marks has the hind legs of a lion (para. 43). The signs at issue present a low degree of conceptual similarity, so the BoA was wrong (para. 45). **On the third plea in law.** Since the BoA relied on the incorrect assumption that the signs at issue are different in order to reject the ground for invalidity provided for in Article 60(2)(c) EUTMR, it must be held that it erred in law. Consequently, the third plea must also be upheld (para. 50).

♦ [T-264/17](#); **SMATRIX / AsyMatrix (fig.)**; *Uponor Innovation AB v EUIPO*; Judgment of 6 June 2018; EU:T:2018:329; Language of the case: EN

EUTM application	Earlier trade mark
<b>SMATRIX</b>	AsyMatrix <del>X</del>

The EUTM applicant sought to register the word mark **SMATRIX** for the goods and services in Classes 9, 11 and 37. An opposition based on the earlier trade mark above was filed pursuant to Article 8(1)(b) EUTMR for all the abovementioned goods and services. The Opposition Division (OD) partially upheld the opposition regarding the goods in Class 11 and the services in Class 37 and rejected it for the goods in Class 9. The applicant appealed against the OD’s decision which was annulled by the Board of Appeal (BoA) as it found that there was a likelihood of confusion (LOC). The EUTM applicant appealed to the General Court (GC), relying on a single plea in law: infringement of Article 8(1)(b) EUTMR. **Relevant public.** The BoA correctly found that the goods and services in Classes 9, 11 and 37 are aimed at the general public, with a high level of attention, and at the relevant professional public (para. 20). **Comparison of the goods and services.** The goods in



Class 9 of the mark applied for are largely covered by the more general category of the earlier mark's *parts and fittings for heating elements and heating installations* in Class 11 (para. 33). The BoA did not err in finding that the goods in Class 9 and the goods in Class 11 were similar (para. 35). The BoA also correctly confirmed that the contested mark's goods in Class 11 were identical to the earlier mark's goods in Class 11 (para. 36). It also found that the services in Class 37 of the mark applied for were similar to the earlier mark's goods in Class 11 (para. 51). In fact, at the time of the sale of the goods in Class 11 many producers were offering after-sales services (para. 41). **Comparison of the signs.** The BoA was right in finding that the word element 'asymatrix' would be perceived by the relevant public as the distinctive and dominant element of the earlier mark (paras 57 and 59). It was also correct to hold that it is the word element 'smatrix' as a whole which produces an impression on the relevant public (para. 61). The word element 'asymatrix' contains the seven letters which make up the word element 'smatrix', six in the same order (para. 64). The BoA was correct in finding that the signs at issue were visually similar (para. 68). Part of the relevant public, namely the Spanish public, will pronounce the earlier mark 'asi-ma-trix', and the mark applied for 'esmatrix'. The pronunciation of the initial part of the signs will be relatively similar and the rest will be identical (para. 70). They are phonetically similar to an average degree (para. 71). The relevant public would associate the intervener's earlier mark with the word 'asymmetric' because the key characteristic of the product is that it is designed with an asymmetric plate (para. 78). So, the BoA was wrong in finding that neither of the signs at issue had any meaning, and this error led to its failure to examine a potentially relevant factor in the overall assessment of the LOC between the marks (para. 83). The single plea must be upheld and the contested decision consequently annulled (para. 87).

**T-294/17; Lion's Head / LION CAPITAL et al.; Lion's Head Global Partners LLP v EUIPO;** Judgment of 14 June 2018; EU:C:2018:345; Language of the case: EN. The IR holder designated the EU for the word mark **Lion's Head** covering, inter alia, *insurance, financial affairs, monetary affairs, and real estate affairs* in Class 36. An opposition based on the EU word mark **LION CAPITAL**, registered for the same services, was filed by the opponent pursuant to Article 46 EUTMR. The Opposition Division (OD) upheld the opposition. The Board of Appeal (BoA) dismissed the IR holder's appeal. The IR holder appealed to the General Court (GC) to annul the BoA's decision relying on a single plea in law, namely, infringement of Article 8(1)(b) EUTMR submitting that the marks at issue are not visually, phonetically or conceptually similar. **Visual similarity.** As 'lion' is the first word of both marks, the marks are visually similar (para. 25). The fact that the pronunciation of 'head' in the IR is emphasised does not alter the visual similarity (para. 26). **Phonetic similarity.** The fact that the marks at issue do not have exactly the same number of syllables does not in itself exclude the possibility that those marks may be phonetically similar (para. 32). **Conceptual similarity.** Since both marks refer to lions, it cannot be disputed that they are conceptually similar (para. 35). The reference of the earlier mark to a lion, in its entirety, includes the head and the other body parts of the animal, resulting in the conceptual similarity of the two marks (para. 36).



**T-310/17; LION'S HEAD global partners (fig.) / LION CAPITAL et al.;** *Lion's Head Global Partners LLP v EUIPO*; Judgment of 14 June 2018; EU:C:2018:344; Language of the case: EN

IR designating the EU	Earlier trade mark
	<p>LION CAPITAL</p>

The IR holder designated the EU for the figurative mark above covering, inter alia, *insurance, financial affairs, monetary affairs, and real estate affairs* in Class 36. An opposition based on the EU word mark **LION CAPITAL**, registered for the same services, was filed by the opponent pursuant to Article 46 EUTMR. The Opposition Division (OD) upheld the opposition. The Board of Appeal (BoA) dismissed the IR holder's appeal. The IR holder appealed to the General Court (GC) to annul the BoA's decision relying on a single plea in law, namely, infringement of Article 8(1)(b) EUTMR submitting that the marks at issue are not visually, phonetically or conceptually similar. **Dominant and distinctive elements.** In the IR, the non-descriptive verbal element 'Lion's Head' is the most distinctive element. It is also the dominant element given its distinctive character, larger size and central position (paras 25-27). The non-descriptive word 'lion' constitutes the sole distinctive element of the earlier mark (para. 38). **Visual similarity.** The presence of the dominant and distinctive word 'lion' in both marks suffices to conclude that the marks are visually similar (para. 32). The fact that the pronunciation of the word 'head' in the IR is emphasised does not alter the assessment that visual similarity exists (para. 33). **Phonetic similarity.** The fact that the marks at issue do not have exactly the same number of syllables does not in itself exclude the possibility that those marks may be phonetically similar (para. 39). **Conceptual similarity.** Since both marks refer to lions, it cannot be disputed that they are conceptually similar (para. 42). The reference of the earlier mark to a lion, in its entirety, includes the head and the other body parts of the animal, resulting in the conceptual similarity of the two marks (para. 43).





♦ [T-164/17](#); **WILD PINK / PINK LADY et al.**; *Apple and Pear Australia Ltd v EUIPO*; Judgment of 15 October 2018; EU:T:2018:678; Language of the case: EN

EUTM application	Earlier trade marks
<p>WILD PINK</p>	<p style="text-align: center;">PINK LADY</p> 

The applicant sought to register the word mark **WILD PINK** as an EUTM for goods in Classes 29 to 31. An opposition, based on the earlier EU and national (Benelux, German, UK, French) word marks **PINK LADY** as well as the earlier EU figurative marks above, registered for goods in Classes 29 to 31, was filed pursuant to Article 8(1)(b) EUTMR and Article 8(5) EUTMR. The Opposition Division (OD) dismissed the opposition and the opponent filed an appeal. The Board of Appeal (BoA) dismissed the appeal without assessing any reputation the earlier marks may enjoy, since it found them to be dissimilar to the mark applied for. The opponents filed an action before the General Court (GC), relying on four pleas in law: (i) infringement of Article 95(1) EUTMR, (ii) infringement of Article 94 EUTMR and Article 296 TFEU, (iii) infringement of Article 8(1)(b) EUTMR and (iv) infringement of Article 8(5) EUTMR. **Descriptive and dominant element.** The word element ‘pink’ is descriptive, as it indicates a specific quality of the goods, namely their colour (para. 69). The term ‘pink’ plays a secondary but not negligible role vis-à-vis that of the word ‘lady’, which is at the end of the earlier mark, and the word ‘wild’, which is at the beginning of the contested mark (paras 73-74). **Visual and phonetic similarity.** Due to the common word ‘pink’, which is not negligible, the signs have, at least, a low degree of visual and phonetic similarity (paras 79, 81). **Conceptual similarity.** Both the relevant English-speaking and non-English-speaking public will perceive the presence of the word ‘pink’ in both signs as denoting the colour pink (para. 88). The word ‘pink’ must be regarded as part of basic English vocabulary regularly used both in everyday life and in advertising. It is clear that the relevant public throughout the EU has had extensive and repeated exposure to that word (para. 58). The non-English-speaking public will also understand the meaning of the word ‘lady’, since it can be found in most dictionaries in the official languages of the EU and, even if it does not appear, its meaning is well known, since it is a common English word very widely used in most languages of the EU and in the media (para. 86). The presence of the square in the figurative marks does not convey any meaning other than the colour pink (para. 90). Therefore, the signs have some conceptual similarity, which is deemed to be low, due to the descriptiveness and low distinctiveness of the term ‘pink’ (para. 89). **Global assessment.** On the basis of an incorrect assessment, the BoA wrongly concluded that the signs were dissimilar overall, without carrying out any global assessment of LOC (para. 91). **On infringement of Article 8(5) EUTMR.** The BoA erred in finding that



Article 8(5) EUTMR was not applicable without carrying out an overall assessment that also took into account the renown or reputation enjoyed by the earlier mark (para. 101).

♦[T-416/17](#); **fino Cyprus Halloumi Cheese (fig.) / HALLOUMI (Collective Mark)**; *Foundation for the Protection of the Traditional Cheese of Cyprus named Halloumi v EUIPO*; Judgment of 23 November 2018; EU:T:2018:834; Language of the case: EN

EUTM application	Earlier trade mark
	<p style="text-align: center;"><b>HALLOUMI</b></p>

The applicant sought to register the figurative mark above as an EUTM for goods in Class 29 (*cheese made out of cow's milk and/or sheep's milk and/or goat's milk (from any milk proportion and combination); rennet*). An opposition based on the earlier EU collective word mark **HALLOUMI** registered for goods in Class 29 (*cheeses*), was filed pursuant to Article 8(1)(b) EUTMR and Article 8(5) EUTMR. The Opposition Division (OD) dismissed the opposition, so the opponent filed an appeal. The Board of Appeal (BoA) compared the marks and found that there was no visual, phonetic or conceptual similarity. The opponent filed an action before the General Court (GC), relying on a single plea in law: infringement of Article 8(1)(b) EUTMR. **Relevant public.** Contrary to the opponent's submissions, the BoA did not seek to limit its analysis to the public of the UK only, but has merely referred to the perception of the term 'fino' by that public on account of its resemblance to the English word 'fine', and its meaning in Spanish or Italian, solely in assessing the distinctiveness of that term as it appears in the contested trade mark (para. 31). The relevant public is the EU average end consumer with an average level of attention (para. 30). **Similarity of the goods.** The goods are identical (para. 30). **Similarity of the signs.** (i) Visual similarity is low. The word 'fino' is dominant because of its central position and its size, colour and inclusion in a golden, oval background, which serves to highlight it. The common word element 'halloumi', situated in the lower part of the sign, is also in a central position, written in white letters on a red background, enabling it to easily stand out; however, it is the sole element composing the earlier mark. The figurative elements of the contested mark do not alter the impression, since they are not very original and do not modify the visibility of the word element 'halloumi' (paras 61-62). (ii) It cannot be excluded that part of that public, albeit a minority, may read the mark in full or pronounce the word 'fino' followed by the word 'halloumi'. The fact that the earlier mark is contained within the contested mark inevitably results in a phonetic similarity, however, due to the different number of syllables, this must be regarded as low (para. 64). (iii) The series of three words 'cyprus halloumi cheese' is only very weakly distinctive, because it is linked with the goods designated by the contested mark. This does not, however, mean that the words, in particular the word 'halloumi', cannot be considered individually by a part of the relevant public. Therefore, there is a low degree of conceptual similarity (para. 66). **No bearing on decision.** The fact that the BoA described the earlier mark as a UK national trade mark is obviously an error of fact with no effect on the legality of that decision (para. 27).



♦ [T-417/17](#); **fino Cyprus Halloumi Cheese (fig.) / HALLOUMI (CERTIFICATION MARK) et al.**; *Republic of Cyprus v EUIPO*; Judgment of 23 November 2018; EU:T:2018:833; Language of the case: EN

EUTM application	Earlier trade mark
	<p style="text-align: center;"><b>HALLOUMI</b></p>

The applicant sought to register the figurative mark above as an EUTM for goods in Class 29 (*cheese made out of cow's milk and/or sheep's milk and/or goat's milk (from any milk proportion and combination); rennet*). An opposition based on the earlier UK certification word mark **HALLOUMI** registered for goods in Class 29 (*cheeses*), was filed pursuant to Article 8(1)(b) EUTMR and Article 8(5) EUTMR. The Opposition Division (OD) dismissed the opposition, so the opponent filed an appeal. The Board of Appeal (BoA) compared the marks and found that there was no visual, phonetic or conceptual similarity. It also found that the references to the nature of UK certification marks and the scope of the protection that they confer under national law are irrelevant at the comparison of the signs stage. The opponent filed an action before the General Court (GC), relying on a single plea in law: infringement of Article 8(1)(b) EUTMR. **Relevant public.** Since the earlier mark is a UK mark, the relevant public is the UK general public. In the light of the category of the goods and their low price, the level of attention of that public is low to average (para. 41). **Comparison of the goods.** The goods are identical (para. 41). **Comparison of the signs.** (i) Visual similarity is low. The word 'fino' is dominant because of its central position and its size, colour and inclusion in a golden, oval background, which serves to highlight it. The common word element 'halloumi', situated in the lower part of the sign, is also in a central position, written in white letters on a red background, enabling it to easily stand out; however, it is the sole element composing the earlier mark. The figurative elements of the contested mark do not alter the impression, since they are not very original and do not modify the visibility of the word element 'halloumi' (paras 58-59). (ii) It cannot be excluded that part of that public, albeit a minority, may read the contested mark in full or pronounce the word 'fino' followed by the word 'halloumi'. The fact that the earlier mark is contained within the contested mark inevitably results in a phonetic similarity, however, due to the different number of syllables, this must be regarded as low (para. 61). (iii) The concept conveyed by the earlier mark, which contains the series of three words 'cyprus halloumi cheese', is only very weakly distinctive, because it is linked with the goods designated by the contested mark. This does not, however, mean that the words, in particular the word 'halloumi', cannot be considered individually by a part of the relevant public. Therefore, there is a low degree of conceptual similarity (para. 63). **Certification mark.** The reasoning regarding the assessment of the distinctiveness of the earlier mark as a UK certification mark is irrelevant to the assessment of the lawfulness of the contested decision (para. 66).



♦ **T-702/17; PAP PAPOUIS HALLOUMI / HALLOUMI (I)**; *Foundation for the Protection of the Traditional Cheese of Cyprus named Halloumi v EUIPO*; Judgment of 23 November 2018; EU:T:2018:832; Language of the case: EN

EUTM application	Earlier trade mark
	<p style="text-align: center;"><b>HALLOUMI</b></p>

The applicant sought to register the figurative mark above as an EUTM for goods in Class 29 (*cheese made out of cow's milk and/or sheep's milk and/or goat's milk (from any milk proportion and combination), rennet*). An opposition based on the earlier EU collective word mark **HALLOUMI** registered for goods in Class 29 (*cheese made from sheep's and/or goat's milk; cheese made from blends of cow's milk; all included in Class 29*), was filed pursuant to Article 8(1)(b) EUTMR and Article 8(5) EUTMR. The Opposition Division (OD) dismissed the opposition, so the opponent filed an appeal. The Board of Appeal (BoA) compared the marks and found that there was no visual, phonetic or conceptual similarity. It found that, given the low inherent distinctiveness of the earlier mark and since the latter was not geographically descriptive, it could not fall within the exception of Article 74(2) EUTMR, which authorises the registration of an EU collective mark that is descriptive. With regard to the enhanced distinctiveness acquired through use of the earlier mark, the evidence adduced is not relevant, since it only shows use of the term 'halloumi' as a generic name designating a speciality cheese of Cyprus, but not as an EU collective mark. The opponent filed an action before the General Court (GC), relying on a single plea in law: infringement of Article 8(1)(b) EUTMR. **Relevant public.** The relevant public is made up of average end consumers, given that cheese is a product that everyone consumes almost daily (para. 12). **Similarity of the signs.** (i) Visual similarity is low: although the common word element 'halloumi' is in a central position, written in stylised, white characters surrounded by blue and gold, however, it is the sole element composing the earlier mark. The figurative elements of the contested mark do not alter that impression, since they are not very original and do not modify the word element 'halloumi' (paras 54-55). (ii) It cannot be excluded that the relevant public will read the three, equally dominant, elements of the contested mark in full. The fact that the earlier mark is contained within the contested mark necessarily entails phonetic similarity when the three elements forming the expression 'pap papouïs halloumi' are pronounced. However, the degree of similarity is low due to, inter alia, the different number of syllables (para. 57). (iii) The elements 'pap' and 'papouïs' are clearly distinctive and dominant in the contested mark, but the concept conveyed by the earlier mark via the word 'halloumi' (which might be considered individually, despite its weak distinctiveness) must lead to a finding that there is a low degree of conceptual similarity (para. 59). **Previous judgments.** The configuration of the earlier mark is different from the one in the judgments invoked by the Office regarding the common element, since the word 'halloumi' neither forms part of a larger word element, nor a series of words. Therefore, it retains its autonomy and, consequently, its visibility as regards the public. The solution arising from the three judgments, in which the common word element was incorporated into a longer word element and could be considered as constituting an inseparable unit, cannot be transposed to the present case. It cannot be ruled out that, in the overall impression produced by the contested mark, the word 'halloumi' may be taken into consideration (paras 51-52).



♦ [T-703/17](#); **PAP PAPOUIS HALLOUMI / HALLOUMI (II)**; *Republic of Cyprus v EUIPO*; Judgment of 23 November 2018; EU:T:2018:835; Language of the case: EN

EUTM application	Earlier trade mark
	<p style="text-align: center;"><b>HALLOUMI</b></p>

The applicant sought to register the figurative mark above as an EUTM for goods in Class 29 (*cheese made out of cow's milk and/or sheep's milk and/or goat's milk (from any milk proportion and combination), rennet*). An opposition based on the earlier UK certification word mark **HALLOUMI** registered for goods in Class 29 (*cheese made from sheep's and/or goat's milk; cheese made from blends of cow's milk; all included in Class 29*), was filed pursuant to Article 8(1)(b) EUTMR and Article 8(5) EUTMR. The Opposition Division (OD) dismissed the opposition, so the opponent filed an appeal. The Board of Appeal (BoA) compared the marks and found that there was no visual, phonetic or conceptual similarity. As for the fact that the contested mark is a UK certification mark, it stated that this could only be taken into consideration during the overall assessment of the likelihood of confusion (LOC). The opponent filed an action before the General Court (GC), relying on a single plea in law: infringement of Article 8(1)(b) EUTMR. **Relevant public.** Since the earlier mark is an EU mark, the relevant public is the UK general public. In light of the category of the goods and their low price, the level of attention is low to average (para. 38). **Similarity of the goods.** The goods are identical (para. 38). **Similarity of the signs.** (i) The visual similarity is low: although the common word element 'halloumi' is in a central position, and written in stylised, white characters surrounded by blue and gold in the contested mark, it is the sole element composing the earlier mark. The figurative elements of the contested mark do not alter that impression, since they are not very original and do not modify the word element 'halloumi' (paras 56-57). (ii) It cannot be excluded that the relevant public will read the three, equally dominant, elements of the contested mark in full. The fact that the earlier mark is contained within the contested mark necessarily entails phonetic similarity when the three elements forming the expression 'pap papouis halloumi' are pronounced. However, the degree of similarity is low due to, inter alia, the different number of syllables (para. 59). (iii) The elements 'pap' and 'papouis' are clearly distinctive and dominant in the contested mark, but the concept conveyed by the earlier mark via the word 'halloumi' (which might be considered individually, despite its weak distinctiveness) must lead to a finding that there is a low degree of conceptual similarity (para. 61). **Previous judgments.** The configuration of the earlier mark is different from the one in the judgments invoked by the Office, since the word 'halloumi' neither forms part of a larger word element nor a series of words. Therefore, it retains its autonomy and, consequently, its visibility as regards the public. The solution arising from the three judgments, in which the common word element was incorporated into a longer word element and could be considered as constituting an inseparable unit, cannot be transposed to the present case. It cannot be ruled out that, in the overall impression produced by the contested mark, the word 'halloumi' may be taken into consideration (paras 53-54).

**C. Article 8(3), Article 60(1)(b) EUTMR — Unauthorised filing by agents of the TM proprietor**

♦ [T-7/17](#); **MINERAL MAGIC / MAGIC MINERALS BY JEROME ALEXANDER et al.**; *John*



*Mills Ltd v EUIPO*; Judgment of 15 October 2018; EU:T:2018:679; Language of the case: EN. The applicant sought to register the word mark **MINERAL MAGIC** as an EUTM for goods in Class 3. An opposition based on, inter alia, the earlier American word mark **MAGIC MINERALS BY JEROME ALEXANDER**, designating the goods *face powder featuring mineral enhancements* was filed pursuant to Article 8(3) EUTMR. The Opposition Division (OD) dismissed the opposition. The opponent filed an appeal and the Board of Appeal (BoA) upheld the appeal. It pointed out that Article 8(3) EUTMR relates not only to cases where the signs and the goods or services compared are identical, but also to cases where they are similar. The applicant filed an action with the General Court (GC), relying on a single plea in law: infringement of Article 8(3) EUTMR. **Identity and not just similarity of the marks for the purposes of Article 8(3) EUTMR.** The intention of the EU legislature was that Article 8(3) EUTMR can be applied only if the proprietor's trade mark and the mark applied for by the agent or representative of the proprietor are identical and not merely similar (para. 37). The fact that the legislature twice refrained from making express mention that the provision at issue should also apply where the trade marks are similar — firstly by amending the pre-draft of the regulation on this point and, secondly, by specifically rejecting a request made by a delegation during the CTMR Working Group within the Council — sufficiently demonstrates its intention with regard to this matter (para. 30). In addition, the same Working Group had agreed that the provision at issue should be interpreted as applying internationally within the meaning of Article 6 *septies* of the Paris Convention, which also refers to the identity of the marks (paras 32, 34). The inclusion of the words 'identical or similar' in Article 8(1)(b) EUTMR and the absence of such words in Article 8(3) EUTMR suggests the obvious application of the latter provision when the trade mark applied for by the agent is the mark of the proprietor (and so, by definition, identical), contrary to the Office's argument that its scope is not limited to cases concerning strictly identical trade marks. Therefore, it seemed unnecessary to the legislature to state this specifically (para. 36). However, regarding the level of similarity required for the signs to be considered identical, case-law indicates that a sign is identical to another where it reproduces, without any modification or addition, all the elements constituting the other sign. In the same vein, the issue of identity has also been examined, in a more indirect manner, in the context of assessing the genuine use of a trade mark (paras 38-39). **Comparison of the signs in issue.** It should be determined whether the signs at issue are identical within the meaning of the judgment *iDrive / IDRIVE* (03/12/2015, T-105/14, *iDrive / IDRIVE*, EU:T:2015:924) taking into consideration the criteria set out in the judgment *Bainbridge* (23/02/2006, T-194/03, *Bainbridge*, EU:T:2006:65) (para. 40). The contested trade mark differs from the earlier trade mark in that the order of the words 'mineral' and 'magic' is reversed and in that it contains neither the letter 's' nor the expression 'by Jerome Alexander'. The BoA correctly held on this basis that the signs should be considered similar. The conclusion that the signs are not identical is so obvious that it applies irrespective of any difference in perception that the average consumer may have depending on the territory (para. 41). Since the signs are not identical, the BoA erroneously held that it could rely on Article 8(3) EUTMR to refuse the registration of the contested mark (para. 42).



**D. Article 8(4), Article 60(1)(c) EUTMR — Non-registered marks/other signs used in the course of trade**

♦[T-118/16](#); **BEPOST / ePOST (fig.) et al.**; *Deutsche Post AG v EUIPO*; Judgment of 20 February 2018; EU:T:2018:86; Language of the case: EN



EUTM application	Earlier rights
BEPOST	POST  Non-registered mark: POST

The word mark **BEPOST** was sought to be registered as an EUTMR covering the goods and services in Classes 16, 35, 38 and 39. An opposition was filed, inter alia, on the earlier German word mark **POST** (services in Classes 35 and 39) and the EU figurative mark above (goods and services in Classes 9, 35, 36, 38, 39, 40, 41 and 42) and the non-registered mark or sign used in the course of trade **POST**. The grounds invoked were based on infringement of Article 8(1)(b) and Articles 8(4) and 8(5) EUTMR. The Opposition Division (OD) dismissed the opposition and the opponent appealed. The Board of Appeal (BoA) dismissed the appeal, insofar as it found that the signs showed significant visual, aural and conceptual differences which were sufficient to rule out a likelihood of confusion, as required by Article 8(1) EUTMR and national law. The possibility of association or the creation of a mental link for the purpose of Article 8(5) EUTMR was rejected taking into account that the German word ‘post’ was a generic term widely used to refer to postal and related services. The opponent filed an action before the General Court (GC) relying on three pleas in law: (i) infringement of Article 8(1)(b) EUTMR, (ii) infringement of Article 8(4) EUTMR and (iii) infringement of Article 8(5) EUTMR. **On the earlier German word mark POST: relevant public.** The relevant public is composed of professionals and consumers in Germany with an overall average level of attention (para. 31). **Comparison of goods and services.** The contested mark’s goods and services are identical, similar or remotely similar to the earlier mark’s services (para. 33). **Comparison of signs.** The signs showed, despite their (weak) common element ‘post’, significant visual, aural and conceptual differences, because of the difference in the length of the word elements as well as the slightly dominant word element ‘be’ at the beginning of the contested mark, which does not allude to postal services (paras 43-49). Although a significant percentage of the relevant public recognises the trade mark significance of the word ‘post’, that does not, by itself, demonstrate that said term can be perceived only as that mark when it is incorporated in marks which differ in overall appearance, pronunciation and concept (para. 47). **No LOC.** In order to assess LOC, the BoA duly took into account the proof of enhanced distinctiveness of the earlier mark and correctly assessed the distinctiveness and dominance of the components of the marks, the degree of similarity of the marks and the goods and services, as well as the fact that the element ‘BE’ of the contested sign was placed at the beginning of the short contested mark and was slightly dominant. No LOC confirmed (para. 72). **On the eu figurative mark: Relevant public.** The relevant public is composed of consumers in the EU (para. 74). **Comparison of goods and services.** Part of the goods and services are dissimilar, part identical or at least somewhat similar (para. 75). **Comparison of signs.** Visually the signs are similar to a low degree, inter alia, because the first word element of the earlier figurative mark is ‘e’ whereas the first word element of the contested mark is ‘be’ There are further visual differences resulting from the different colours and typefaces used



and the way in which those different elements are arranged and the distinctive character of those elements is no weaker than that of the word element ‘post’ (para. 81). The ‘e’ in the earlier mark ePOST will be understood as meaning ‘electronic, indicating the involvement of the internet’, which represents a conceptual difference between it and the mark applied for (para. 83). **No LOC.** The distinctive character of the two word elements ‘e’ and ‘post’ of the earlier EU figurative mark ePOST is weak (para. 88). The signs are similar to a low degree, since, despite their common element ‘post’, they show significant visual, aural and conceptual differences (para. 89). The common element ‘post’, which is not separated from the word element ‘be’ by a space, does not play the same role in the two marks at issue (paras 69 and 91). Even if the common element ‘post’ may potentially have some independent distinctiveness due to the registration of the sign **POST** as an earlier national word mark, it is rather likely to be seen as a mere reference to postal services in the contested mark, and, therefore, it is purely descriptive (paras 91-92). Therefore, due to the above and given the different overall impression of the marks because of the differences between the word elements at the beginning of the signs in different graphic styles, there is no LOC (para. 90). The same applies for the non-registered mark or sign used in the course of trade **POST** (paras 101-102).

♦**C-478/16 P**; **GROUP Company TOURISM & TRAVEL (fig.) / GROUP Company TOURISM & TRAVEL (fig.); EUIPO v Group ODD**; Judgment of 19 April 2018; EU:C:2018:268; Language of the case: BG

EUTM application	Earlier non-registered sign
	

The applicant sought to register the figurative mark above as an EUTM for services in Classes 35, 39 and 43. An opposition was filed based on the earlier non-registered figurative sign above, used in Bulgaria, Czechia, Hungary, Poland and Slovakia as a company name for transportation services. The Opposition Division (OD) dismissed the opposition insofar as the opponent had not specified or provided any evidence about the applicable national law on which it was relying and under which the use of the mark sought might have been prohibited in the Member States concerned. The opponent filed an appeal and submitted references to Bulgarian law. The Board of Appeal (BoA) dismissed the appeal, as it found that the documents produced by the applicant before the OD did not contain any reference to Bulgarian law. The BoA found that the references to three legal provisions in the statement of grounds of appeal, had been submitted late. According to the BoA, the required reference to the legal bases must be made within the time limits granted during opposition proceedings. It also found that the applicant had referred only to the text of Article 12(1) of the Bulgarian law on trade marks and geographical indications, without providing the original Bulgarian version or proving that that text originated from an official and reliable source. The opponent filed an action before the General Court (GC) relying on three pleas in law: (i) infringement of Article 95(1) EUTMR, (ii) infringement of Article 95(2)





EUTMR, and (iii) infringement of Article 8(4) EUTMR. The GC upheld the action insofar as it found that the **particulars of the national legislation** supplemented the initial evidence which concerned the use in the course of trade of an unregistered sign, with both sets of evidence being regarded together as ‘one piece of evidence proving the acquisition, permanence and the scope of the protection of an earlier right’. Therefore, the BoA could not rule out the admissibility of the content of the national law, submitted for the first time before it, without exercising its discretion under Article 95(2) EUTMR. Furthermore, the BoA could not require the opponent to produce an extract from the Darzhaven vestnik or the official Bulgarian text. If the BoA had doubts about the faithful reproduction, applicability or interpretation of the Bulgarian law relied on by the applicant, it was required to exercise its powers of verification. The Office filed an action before the Court of Justice of the European Union (CJ) relying on two pleas in law: (i) infringement of Article 95(2) EUTMR in conjunction with Rule 50(1) of Regulation No 2868/95 and (ii) infringement of Article 8(4) of Regulation No 207/2009 in conjunction with Article 7(2)(d) EUTMDR. Regarding the second plea concerning the alleged infringement of Article 8(4) EUTMR in conjunction with Article 7(2)(d) EUTMDR, the Court of Justice held that the opponent is free to choose the evidence it considers useful to submit to the Office in support of its opposition regarding a non-registered right (para. 58). Moreover, the Office is obliged to examine all the evidence submitted in order to determine whether it proves that the earlier mark was registered or filed, and cannot reject out of hand a particular type of evidence on the sole account of the form it takes (para. 58). No specific formalism is needed for the substantiation of a non-registered right (para. 56). It is clear that neither EU trade mark legislation nor the case-law identifies the manner in which the content of national legislation must be proven. Therefore, the BoA could not require the opponent to produce an extract from the Darzhaven vestnik or the official Bulgarian text (para. 59). The text of the legislation originating from an official source is not indispensable in order to enable the applicant to exercise its rights of defence (para. 60). It suffices that the elements of national law must enable the Office to identify correctly and unequivocally the applicable law (para. 61).

**C-75/17 P; PALLADIUM PALACE IBIZA RESORT & SPA (fig.); Fiesta Hotels & Resorts, S.L. v EUIPO**; Judgment of 19 April 2018; EU:T:2018:269; Language of the case: ES

EUTM	Earlier trade mark
	<p>GRAND HOTEL PALLADIUM</p>

The EUTM proprietor was granted the registration of the figurative mark above for services in Classes 41 and 43. An application for invalidity pursuant to Article 60(1)(c) EUTMR in conjunction with Article 8(4) EUTMR, based on the earlier name **GRAND HOTEL PALLADIUM** used in Spain in the course of trade for restaurant and temporary accommodation services, was upheld by the Cancellation Division (CD) insofar as the services in Class 43 were concerned. The Board of Appeal (BoA) dismissed the EUTM proprietor’s appeal. It found that the earlier sign had been used in Spain in the course of trade to designate a hotel and that the scope of that use was not merely local. It also found that the trade name allowed the invalidity applicant, under Spanish law, to prohibit the use



of a subsequent trade mark where there was a likelihood of confusion. The EUTM proprietor appealed to the General Court (GC) relying on two pleas in law: (i) infringement of Article 60(1)(c) EUTMR in conjunction with Article 8(4) EUTMR and (ii) infringement of Article 8(1)(b) EUTMR and Spanish case-law on so-called intermediary marks. The GC dismissed the appeal. The EUTM proprietor appealed to the Court of Justice of the European Union (CJ) on four grounds, three based on the infringement of Article 8(4) EUTMR and the fourth on infringement of Article 72 EUTMR. **Of more than mere local significance.** Given the geographical dispersion of the clientele of the hotel to which the earlier trade name refers, shown by the fact that the invoices submitted to the Office were addressed to people domiciled in at least 16 different Spanish provinces, it can be concluded that the trade name had a geographical scope of more than mere local significance (paras 37-39). **Notorious use or knowledge of the earlier right.** It suffices to state that there is a final decision by a Spanish court declaring that the right to the earlier sign was acquired in conformity with Spanish law, without that conclusion being affected by the existence of a doctrinal and judicial controversy on the scope of the obligation to demonstrate a ‘notorious use or knowledge’ of said right (paras 50-51). **Sign that confers on its proprietor the right to prohibit the use of a subsequent mark.** The GC was right in noting that an EU trade mark may be declared invalid on the basis of a trade name that complies with the legal requirements established in Article 9(1)(d) of the Spanish trade mark law (paras 56-60).

♦ [T-238/17](#); **GUGLER (fig.) / GUGLER FRANCE**; *Alexander Gugler v EUIPO*; Judgment of 25 September 2018; EU:T:2018:598; Language of the case: EN

EUTM application	Earlier trade mark
	<p style="text-align: center;"><b>GUGLER</b></p>

Gugler GmbH, the predecessor in title of the EUTM proprietor, registered the figurative mark above as an EUTM for goods and services in Classes 6, 17, 19, 22, 37, 39 and 42. An invalidity application was filed pursuant to Articles 59(1)(b) and 60(1)(c) EUTMR. In the context of Article 60(1)(c) EUTMR, read in combination with Article 8(4) EUTMR, the invalidity applicant, which was the distributor of Gugler GmbH on the date of the EUTM filing, relied on rights acquired on its company name and on Article L 711-4 of the French Intellectual Property Code, according to which signs may not be adopted as marks if they infringe other rights, such as the names of companies, if there is likelihood of confusion (LOC) for the public. The Cancellation Division (CD) upheld the invalidity application under Article 60(1)(c) EUTMR read in combination with Article 8(4) EUTMR. The EUTM proprietor appealed and the Board of Appeal (BoA) upheld the appeal. The invalidity applicant filed an action before the General Court (GC) who upheld the action, finding that the BoA had infringed the obligation to state reasons. The case was referred back to the BoA for a new decision. After remittal, the BoA dismissed the appeal finding that the invalidity application of the contested mark should be upheld on the basis of Article 60(1)(c) EUTMR read in conjunction with Article 8(4) EUTMR. It took the view that consumers who had been exposed to the company name in the field of building-closing devices reasonably believed that identical or similar closing devices, as well as related insulation goods, marketed in France under the trade mark GUGLER, had the same business origin and therefore concluded that there was a likelihood of confusion within the meaning of Article L 711-4 of the French Intellectual Property Code. The EUTM proprietor filed another action before the



GC, relying on three pleas in law: (i) infringement of the principle of sound administration, (ii) infringement of Article 8(4) EUTMR and (iii) infringement of Article 61(2) EUTMR. **Existence of business relations.** On the date upon which the application for registration of the contested mark was filed, business relations existed between the invalidity applicant and Gugler GmbH, at that time the proprietor of the contested mark. The invalidity applicant was the distributor of Gugler GmbH's goods in France. Their business relationship dated back to 2000, when the invalidity applicant was called PK Fermetures. Since July 2002, Gugler GmbH held 498 shares in the invalidity applicant's capital (para. 36). In 2003, Gugler GmbH formed the company Gugler Europe with French partners, some of which were founders of the invalidity applicant, which has been the proprietor of the French figurative mark GUGLER since 28 August 2003. Gugler Europe granted a licence for that mark to the invalidity applicant (para. 37). **Likelihood of confusion in case of economically linked undertakings.** The finding that there is a likelihood of confusion as to the origin of the contested mark's goods and services presupposes that the relevant public might erroneously believe that the goods and services of that mark and the activities protected by the earlier sign come from economically linked undertakings (para. 42). However, the contested mark's goods are manufactured by the EUTM proprietor while the proprietor of the earlier company name (the invalidity applicant) was the distributor of those goods on the filing date of the contested EUTM, which is the relevant point in time for assessing whether the conditions for the application of Article 8(4) EUTMR are fulfilled. Therefore, this is a case in which the fact that the consumer might believe that the goods and services in question come from economically linked undertakings does not constitute an error as to their origin (para. 43). **Awareness of the relevant public regarding the economic link.** The French public was probably unaware of the existence of Gugler GmbH and of the fact that this undertaking manufactured the goods sold by the invalidity applicant, since the latter did not explicitly present itself as the distributor of Gugler GmbH. The mere fact that the invalidity applicant presented its goods as being manufactured in Maxdorf in Germany is not sufficient for the French public to be aware that this was where Gugler GmbH had its seat (para. 45). The assessment of the likelihood of confusion is an objective one: it is not necessary that the consumer be aware that he or she is mistaken in believing that the goods and services in question come from the same undertaking or from economically linked undertakings. Similarly, he or she cannot be required to know that he or she will not err as to the origin of the goods because he or she is aware of the existence of an economic link between the proprietors of the conflicting signs (para. 46). In order to exclude the likelihood of confusion where the proprietors of the conflicting signs are economically linked, it is not necessary that the consumer be aware of that economic link (para. 48). The economic link between the invalidity applicant, the proprietor of the earlier company name, and Gugler GmbH (the proprietor of the contested mark on the date on which the application for registration was filed) precluded a finding of a likelihood of confusion (para. 49). **No LOC.** Therefore, given the economic link between the parties, and despite the identity or similarity of the goods and services concerned and the high degree of similarity of the signs, there is no LOC within the meaning of Article L 711-4 of the French Intellectual Property Code.

**T-328/16; DEEP PURPLE / DEEP PURPLE;** *Ian Paice v EUIPO*; Judgment of 4 October 2018; EU:T:2018:649; Language of the case: EN. The intervener sought to register the word mark **DEEP PURPLE** as an EUTM for goods and services in Classes 9, 25 and 41. An opposition based on the earlier non-registered mark **DEEP PURPLE** for all the abovementioned goods and services was filed pursuant to Article 8(4) EUTMR. The OD partly upheld the opposition, and the mark applied for was refused registration for some of the goods in Class 9 and all of the services in Class 41. However, it granted the application for registration of the mark for the goods in Class 25 as well as for some of the goods in



Class 9. The applicant appealed against the OD's decision. The Board of Appeal (BoA) dismissed the appeal regarding some of the goods in Class 9, namely *computer hardware [and] computer chips and discs, interactive software as well as computer firmware; computer games; software for interactive games for computer, mobile phones and handheld devices; digital games, mobile phone games; DVD games; computer software and computer programs*. The BoA found that no evidence had been submitted that the band Deep Purple had been involved in trading those items. It also stated that those items fell into a category of goods that were not clearly associated with music business merchandising in general and Deep Purple in particular. This did not, therefore, have the nature of 'notorious fact' evidence (para. 14). The applicant filed an action before the General Court (GC), relying on two pleas in law: (i) alleging that the **Lego** judgment was misapplied and, (ii) alleging deceptive intent on the part of the intervener. The applicant submits that the BoA failed to have regard to the principle established in the **Lego** judgment, according to which, the existence or absence of a common field of activity is not the acid test for establishing the likelihood of misrepresentation. The test is actually whether there is a real risk that a substantial number of persons will in fact believe that there is a business connection between the claimant and the defendant. The BoA did not, however, ask itself that question, instead applying the 'badge of allegiance' test (para. 27). There is no indication in the contested decision that the use of the expression 'badge of allegiance' gave rise to an incorrect conclusion. It is only used by the BoA in order to explain the concept of merchandising in the music industry (para. 34). The applicant has not adduced any evidence that shows that the band Deep Purple have been involved in trading any of the goods at issue or that music bands or other performers or celebrities commonly traded those type of goods (para. 35). The fact that the applicant was involved in trading some of the goods in Class 9 is irrelevant, as that does not imply that the likelihood of misrepresentation is established for all the goods in that class in general or the goods at issue in particular (para. 36). The claim that the intervener sought to deceive the public was set out only in a very summary manner before the BoA. In addition, that claim was not substantiated by any evidence capable of proving that the intervener intended to deceive the public in a manner likely to damage the applicant. Though it is understood that the intervener is a former member of the band and is, therefore, associated with the band in the mind of the public, this cannot in itself amount to proof of a deceptive intent on his part. The BoA dealt fully with the issue of the likelihood of misrepresentation (para. 48). It cannot be successfully argued that the BoA failed to adjudicate on the applicant's argument concerning 'subjective deceptive intent', nor that it failed to state the reasons for which it had not upheld that argument (para. 49).

**T-344/16; DEEP PURPLE / DEEP PURPLE; Richard Hugh Blackmore v EUIPO**; Judgment of 4 October 2018; EU:T:2018:648; Language of the case: EN. The applicant sought to register the word mark **DEEP PURPLE** as an EUTM for goods and services in Classes 9, 25 and 41. An opposition based on the earlier non-registered mark **Deep Purple** was filed pursuant to Article 8(4) EUTMR. The Opposition Division (OD) partially dismissed the opposition, namely for the goods in Class 25 as well as for some of the goods in Class 9. The opponent filed an appeal, which the Board of Appeal (BoA) partially upheld, namely for goods in Class 9 (*mouse mats and mouse pads; sunglasses; mobile phone accessories*) and Class 25 (*clothing, footwear, headgear, etc.*). The applicant appealed to the General Court (GC), relying on four pleas in law: (i) undue admission of belated evidence, (ii) insufficient proof of goodwill, (iii) insufficient proof of the opponent's entitlement to a share in any goodwill and (iv) wrongful assessment of likelihood of misrepresentation. **The first plea in law, alleging undue assessment of the belated evidence.** The evidence was genuinely relevant to the outcome of the opposition and the BoA was not required to consider whether the opponent could have submitted the evidence within the time limit set,





since that is a discretionary matter (para. 55). **The second plea in law, alleging insufficient proof of goodwill.** (i) The press articles published in 2013 (Annex 3) prove that the band Deep Purple had an active and continuous presence in the United Kingdom (UK) during the period preceding the date of application for registration of the contested mark (para. 42). (ii) Annex 4 (list of the band's concerts) shows the band's commercial activity in the UK and mentions, inter alia, numerous concerts and ticket sales in that country between 2003 and October 2013 (para. 43). The argument that Annex 4 has no probative value because it is not supported by any sworn and signed statement cannot be accepted, since it was for the BoA to assess the evidence overall (para. 46). (iii) Annex 5, the list of 19 albums recorded and released between 1968 and 2013, also shows that there was trading activity in the UK at the time of the application for registration. The applicant's argument that those albums were not sold in that country is implausible given the band's fame there, as shown by the press articles, and the fact that one of those articles refers to the sale of 100 million albums (para. 44). The press articles are independent proof that Deep Purple is a UK band that has enjoyed considerable popularity, at least in that territory (para. 45). **The third plea in law, alleging insufficient proof of the opponent's entitlement to a share in any goodwill.** The plea in law is set out in an abstract and incomplete manner in the application, with no mention of the case-law which is being relied on or in what way the evidence was insufficient (para. 61). **The fourth plea in law, alleging wrong assessment of likelihood of misrepresentation.** The BoA duly relied, first, on the evidence concerning the merchandising of clothing in Class 25 and, secondly, on the evidence concerning the importance of merchandising and on the proof of matters of common knowledge (para. 68). *Sunglasses* are sufficiently accessorised with clothing, while *mouse mats and mouse pads; mobile phone accessories* are commonly decorated with commercial or personal imagery, so that there would be misrepresentation if the applicant marketed that category of items under the name **Deep Purple** (para. 67).

**T-345/16; DEEP PURPLE / DEEP PURPLE; Richard Hugh Blackmore v EUIPO**; Judgment of 4 October 2018; EU:T:2018:652; Language of the case: EN. The applicant sought to register the word mark **DEEP PURPLE** as an EUTM for goods and services in Classes 9, 25 and 41. An opposition based on the earlier non-registered mark **Deep Purple** was filed pursuant to Article 8(4) EUTMR. The Opposition Division (OD) partially upheld the opposition for some of the goods in Class 9 and all of the services in Class 41. The applicant filed an appeal, which the Board of Appeal (BoA) dismissed. The applicant appealed to the General Court (GC), relying on three pleas in law: (i) undue assessment of belated evidence, (ii) insufficient proof of goodwill and (iii) insufficient proof of the opponent's entitlement to a share in any goodwill. **The second plea in law, alleging insufficient proof of goodwill.** (i) Press articles published in 2013, contained in Annex 3, prove that the band Deep Purple had an active and continuous presence in the United Kingdom (UK) during the period preceding the date of application for registration of the contested mark. The argument that those articles are evidence of the band's return after a prolonged absence is unconvincing in view of the evidence showing the sale of concert tickets during the period from 2003 to 2013 (para. 35). (ii) Annex 4 (list of the band's concerts) shows the band's commercial activity in the UK in the period preceding the date of the application for registration of the contested mark, and mentions, inter alia, numerous concerts and ticket sales in that country between 2003 and October 2013 (para. 36). The argument that Annex 4 has no probative value because it is not supported by any sworn and signed statement cannot be accepted, since it was for the BoA to assess the evidence overall (para. 39) (iii) Annex 5, the list of 19 albums recorded and released between 1968 and 2013, also shows that there was trading activity in the UK at the time of the application for registration. The applicant's argument that those albums were not sold in that country is implausible given the band's fame there, as shown by the press articles, and the fact that



one of those articles refers to the sale of 100 million albums. The press articles are independent proof that Deep Purple is a UK band that has enjoyed considerable popularity, at least in that territory (para. 37). The applicant’s argument that the evidence in Annex 5 has no probative value (due to lack of substantiating evidence such as invoices, sales receipts, ticket samples or advertising for the concerts) is ineffective (para. 38). **The first plea in law, on undue assessment of belated evidence.** Even if the evidence submitted out of time is not taken into account, goodwill has been established (para. 42). **The third plea in law, alleging insufficient proof of the opponent’s entitlement to a share in any goodwill.** The plea in law is set out in an abstract and incomplete manner in the application. The applicant has failed in particular to state the case-law on which he relied or in what way the evidence was insufficient. In addition, at the hearing, the applicant partially withdrew and reformulated that plea (para. 47).



♦[T-261/17](#); **SALOSPIR 500 mg (fig.) / Aspirin et al.**; *Bayer AG v EUIPO*; Judgment of 24 October 2018; EU:T:2018:710; Language of the case: EN

EUTM application	Earlier rights
	<p data-bbox="979 887 1153 965"><b>Aspirin</b> <b>Aspirin</b></p> 

The applicant sought to register the mark above as an EUTM for goods in Class 5 (*pharmaceuticals*). An opposition was filed pursuant to Article 8(1)(b) EUTMR, Article 8(4) EUTMR (§4(2) German law) and Article 8(5) EUTMR. It was based on the earlier German figurative mark **Aspirin** (above), the earlier German word mark **Aspirin**, the earlier EU figurative trade marks (above), and the non-registered sign **ASPIRIN** (packaging) in Germany. The Opposition Division (OD) dismissed the opposition, so the opponent appealed. The Board of Appeal (BoA) dismissed the appeal. It held that the contested mark was different from the earlier German marks and from the earlier EU figurative marks, and that the opponent had not proved that German law granted protection to the non-registered sign. The opponent filed an action before the General Court (GC), relying on three pleas in law: (i) infringement of Article 8(1)(b) EUTMR, (ii) infringement of Article 8(5) EUTMR, and (iii) infringement of Article 8(4) EUTMR. **Recognition of the non-registered sign.** The opponent, who bears the burden of proof, has not proved to the requisite legal standard, according to the national law upon which it relies, that the potential recognition ‘as a trade mark’ of certain elements that make up the packaging of a product entailed the recognition ‘as a trade mark’ of that packaging (para. 128). Judgments concerning the interpretation of provisions of EU law, rather than the interpretation of German law, are irrelevant (para. 123).



**T-435/12; 42 BELOW (FIG. MARK) / VODKA 42 (FIG. MARK); Bacardi Co. Ltd v EUIPO;** Judgment of 24 October 2018; EU:T:2018:715; Language of the case: EN

EUTM application	Earlier trade mark
	

The applicant sought to register the figurative mark above as an EUTM for goods in Class 33 corresponding to the description *alcoholic beverages (except beers), including vodka, vodka-based and vodka-flavoured beverages*. An opposition based, inter alia, on the earlier non-registered figurative mark used in Czechia and Slovakia for *alcoholic beverages, namely vodka* was filed pursuant to Article 8(1)(b) EUTMR and Article 8(4) EUTMR. The Opposition Division (OD) dismissed the opposition. The opponent filed an appeal. The Board of Appeal (BoA) upheld the appeal. It found that in Czechia, under Article 7(1)(g) of the Czech law on trade marks, proprietors of non-registered trade marks used in the course of trade, with more than mere local significance, prior to the filing of an application for registration, had the right to prohibit subsequent trade marks if the signs were identical or similar and covered similar goods or services. It found that the rights to the non-registered mark had been acquired through its use by the opponent for *alcoholic beverages, namely, vodka* prior to the date on which the application for registration of the contested mark was filed. The applicant filed an action before the General Court (GC), relying on two pleas in law: (i) infringement of Article 32(h) EUTMR, and (ii) infringement of Article 8(4) EUTMR.

**The summary of the applicant’s arguments.** The BoA gave a very detailed summary of the arguments relied on by the applicant before the OD. It referred to the arguments concerning Czech law relating to unfair competition and copyright (para. 38). It also summarised the applicant’s arguments against the opponent’s appeal (para. 39).

**Assessment of use of the non-registered mark.** It is necessary to distinguish the condition for use in the course of trade, which must be assessed in the light of EU law, from that referred to in Article 8(4)(a) EUTMR concerning the acquisition of the right to a non-registered sign, which must be assessed in the light of the law of the Member State in which the sign was used before the date of filing of the EUTM application (para. 64). The fact that Czech law provides for proof of use as a condition for the existence of a non-registered sign has no effect on the date on which the use of the non-registered sign must be assessed (para. 65).

**Assessment of the conditions of Article 8(4) EUTMR under national law.** The BoA did not err in its assessment of the conditions for the application of Article 8(4) EUTMR in light of the provisions of Czech law, by taking all available evidence into account (para. 105). According to the annex to Section 4 of Part C of the Office Guidelines, the basis of protection of a non-registered mark is, as regards Czech law, Article 7(1)(g) of the Czech law on trade marks (para. 97). Even if the Office Guidelines are not binding, the applicant bears the burden of proof in order to show that the right to non-



registered marks was laid down in provisions other than Article 7(1)(g) of the Czech law on trade marks. Article 44 et seq. of the Czech Commercial Code relate to unfair competition, misleading marks and copyright infringement and it does not follow from the documents submitted relating to Article 7(1)(g) of the Czech law on trade marks that said provision should be read in conjunction with those provisions (paras 92, 98). Therefore, the BoA correctly found that Article 7(1)(g) of the Czech law on trade marks conferred protection on non-registered signs and, subsequently, the acquisition of the right to a non-registered sign of more than mere local significance was acquired through use in the course of trade before the filing of the application for registration of a subsequent mark (para. 99). By opposing the registration of a subsequent mark, the proprietors of rights over earlier signs seek effective protection against any future use of that mark (para. 100). The right to oppose the registration of a subsequent mark under Article 7(1)(g) of the Czech law on trade marks implicitly but necessarily includes the right to oppose the use of that mark (para. 102). **Scope of the proceedings.** Regarding the question of whether there are provisions other than those of Article 7(1)(g) of the Czech law on trade marks, which allow the proprietors of a non-registered sign to prohibit the use of a subsequent mark after it has been registered, those articles related to questions outside the sphere of competence of the Office (issues of unfair competition and breach of copyright) (paras 94, 103). The BoA did not err in stating that it was not competent to assess the validity of the non-registered mark and, accordingly, to rule on the existence of any infringement of the applicant's copyright or any act of unfair competition committed to its detriment (para. 113). It was for the applicant to demonstrate that the non-registered mark was invalid by producing definitive administrative or judicial decisions to that effect (para. 114).



**T-459/17; THE COMMODORES / Commodores et al.; *Fifth Avenue Entertainment LLC v EUIPO***; Judgment of 6 December 2018; EU:T:2018:886; Language of the case: EN. 'The Commodores' were a widely known band, formed during the 1970s. The applicant sought to register the word mark **THE COMMODORES** as an EUTM for goods and services in Classes 9 and 41. An opposition, based on, inter alia, the earlier unregistered sign **Commodores**, under the law of several Member States, was filed pursuant to Article 8(4) EUTMR. The Opposition Division (OD) dismissed the opposition. It found that the opposing party had failed to provide information on the content of the applicable national law or the conditions to be fulfilled in order for it to be able to prohibit the use of the mark applied for under the law of the Member States referred to. The opponent appealed pointing out that the earlier unregistered right **Commodores** came under the law of the United Kingdom, namely Section 5(4)(a) of the Trade Marks Act 1994. The Board of Appeal (BoA) upheld the appeal and rejected the registration of the mark. The applicant filed an action before the General Court (GC), relying on two pleas in law: (i) infringement of Article 8(4) EUTMR and (ii) infringement of Article 95 EUTMR. **Earlier unregistered sign in the UK.** One of the four cumulative conditions that an earlier sign other than a registered mark must meet in order to oppose the registration of an EUTM, pursuant to Article 8(4) EUTMR, is the condition that the sign confer on its proprietor the right to prohibit the use of a subsequent trade mark in the light of the criteria set by the law governing the sign relied on. In this case that is the UK Trade Marks Act 1994, which provides in Section 5(4) that '[a] trade mark shall not be registered if, or to the extent that, its use in the United Kingdom is liable to be prevented: (a) by virtue of any rule of law (in particular, the law of passing off) protecting an unregistered trade mark or other sign used in the course of trade...' (paras 22, 28, 31). The Court has previously held that the party invoking that provision must establish, inter alia, the goodwill acquired by the earlier sign (para. 32). The BoA concluded that the goodwill in the business operating under the name 'The Commodores' was owned by the opponent and is protectable under UK law, which therefore enables it to prohibit the use of the mark applied for in the context of an action for passing off. The BoA also held that the applicant was not





entitled to the sole proprietary right over the mark **THE COMMODORES** as, according to the general partnership agreement entered into by the members of the band and one other person on 20 March 1978, they had assigned their rights to a company, which subsequently merged with the opponent. The BoA, however, failed to take into account that the term of the general partnership agreement was limited to seven years. While the BoA referred to a number of relevant clauses from that agreement, it did not examine the effect resulting from the expiry of its validity (para. 36). It must, therefore, be held that the BoA could not, without erring in its assessment, conclude on the basis of, inter alia, an agreement (the term of which had expired) that the ‘common-law ownership’ of the name ‘The Commodores’ resided with the opponent and that said agreement clearly showed that the founding members had assigned their rights to the opponent, with the result that the applicant could not rely on a ‘sole proprietary right to the mark [The Commodores]’ (para. 38). By merely concluding that the applicant could not rely on the ‘sole proprietary right to the mark [The Commodores]’, the BoA omitted to examine whether the applicant was the co-owner of that right and, if that were the case, the impact of this co-ownership in light of the national law relied on (para. 39). The national law relied on provides that, in certain circumstances, several persons can simultaneously own separate goodwill in a name, with the result that they are permitted to use that name simultaneously. In these circumstances, an action for passing off brought against a party that owns separate goodwill, by another party that also owns goodwill in that name, is bound to fail (para. 40). Therefore, the BoA failed to examine to the requisite legal standard whether the fourth condition set out in Article 8(4) EUTMR, namely that the national law relied on confers on the intervener the right to prohibit the use of the mark applied for, was satisfied (para. 43). It follows that the first plea must be upheld and that the contested decision must be annulled, without it being necessary to examine the other arguments raised in the context of the first and second pleas (para. 44).

♦[T-274/17](#); **MONSTER DIP (fig.) / MONSTER ENERGY (fig.) et al.**; *Monster Energy Company v EUIPO*; Judgment of 13 December 2018; EU:T:2018:928; Language of the case: EN

EUTM application	Earlier rights
	 <p data-bbox="927 1621 1209 1682">MONSTER ENERGY MONSTER</p> <p data-bbox="772 1682 1369 1720">UK non-registered TM ‘MONSTER ENERGY’</p>

The applicant sought to register the figurative mark above as an EUTM for goods and services in Classes 2, 37 and 40. An opposition based on the EU word marks **MONSTER ENERGY** and **MONSTER**, the EU figurative mark above and the unregistered UK mark **MONSTER ENERGY**, inter alia, was filed pursuant to Article 8(1)(b) EUTMR, Article 8(4) EUTMR and Article 8(5) EUTMR. The Opposition Division (OD) dismissed the opposition. The opponent appealed, which the Board of Appeal (BoA) dismissed, finding that the goods and services were dissimilar. It stated that reputation had only been established for the earlier EU figurative mark **MONSTER ENERGY** and that it would only, therefore, take that



earlier mark into account. It found that the marks were similar ‘to at least a certain extent’, but taking all the circumstances of the case into account, there was no link between the marks. The opponent filed an action before the General Court (GC), relying on five pleas in law: (i) the BoA wrongly held that the goods and services were different, (ii) the BoA wrongly rejected the existence of a conceptual similarity between the contested mark and the earlier EU figurative mark **MONSTER ENERGY**, (iii) the BoA wrongly held that the relevant public would not establish a link between those marks, (iv) the BoA wrongly concluded that the distinctive character of the earlier marks was not undermined, (v) the BoA erred in failing to analyse the application of Article 8(4) EUTMR. **Article 8(4) EUTMR.** The goods *non-alcoholic drinks*, identical to those of the unregistered UK mark **MONSTER ENERGY**, and the contested mark’s goods and services, were so dissimilar that the relevant public would not establish any link with the world of *alcoholic drinks* of the unregistered UK mark **MONSTER ENERGY** (para. 95). Therefore, the reasoning of the BoA also covers the fact that one of the conditions laid down in UK law regarding the action for passing off is not fulfilled (para. 96).

#### E. Article 8(2)(c), 8(5), 60(1)(a) EUTMR — Well-known marks / trade marks with a reputation

♦[T-398/16](#); **COFFEE ROCKS / STARBUCKS COFFEE (fig.) et al.**; *Starbucks Corp v EUIPO*; Judgment of 16 January 2018; EU:T:2018:4; Language of the case: EN. Registration as an EUTM was sought for the figurative mark ‘COFFEE ROCKS’ for services in Class 43. An opposition was filed based, inter alia, on earlier EU and national trade marks consisting of the figurative sign ‘STARBUCKS COFFEE’, registered, inter alia, for services in Class 43, pursuant to Article 8(1)(b) and Article 8(5) EUTMR. The Opposition Division (OD) dismissed the opposition in its entirety and the opponent filed an appeal. The Board of Appeal (BoA) confirmed the OD decision and dismissed the opponent’s appeal. The opponent filed an action before the General Court (GC) relying on two pleas in law: (i) infringement of Article 8(1)(b) EUTMR and (ii) infringement of Article 8(5) EUTMR. **Reputation.** The similarity between the signs has to be capable of leading the relevant public to establish a link between the signs, but does not require that similarity to be capable of leading that public to confuse those signs (paras 78-79). The BoA erred in ruling out any similarity between the signs and should not have refused to assess the grounds set out in Article 8(5) EUTMR because the marks were dissimilar (para. 83).

♦[T-102/17](#); **SANTORO (fig.) / SANGRE DE TORO et al.**; *Cantina e oleificio sociale di San Marzano v EUIPO*; Judgment of 1 February 2018; EU:T:2018:50; Language of the case: EN. The applicant sought to register the figurative sign ‘SANTORO’ for *Italian wines* in Class 33. The opponent filed an opposition pursuant to Article 8(1)(b) and Article 8(5) EUTMR against all the goods in Class 33, based on, inter alia, the EU word mark **SANGRE DE TORO**, registered for *alcoholic beverages (except beers)*. The Opposition Division (OD) rejected the opposition on the ground that there was no likelihood of confusion (LOC) between the marks at issue and no link proved for Article 8(5) EUTMR. The Board of Appeal (BoA) upheld the appeal brought by the opponent and annulled the OD’s decision, holding essentially that, in the light of the identical nature of the goods and the similarity of the signs, there was a LOC on the part of the relevant public. In its application for annulment, the applicant raised three pleas in law: (i) infringement of Article 8(1)(b) EUTMR on the ground that the BoA did not correctly assess the similarity of the goods, (ii) infringement of Article 8(1)(b) EUTMR on the ground that the BoA did not correctly assess the similarity of the signs, (iii) infringement of Article 8(5) EUTMR and distortion of the evidence in relation to the assessment of the reputation of the earlier mark. **The**



**assessment of reputation.** As the opposition could be fully upheld under Article 8(1)(b) EUTMR, it was not necessary for the BoA to assess whether the earlier trade mark had a reputation. Therefore, the applicant’s arguments that the reputation of the earlier mark was not shown are ineffective (paras 62-63).

♦**T-118/16; BEPOST / ePOST (fig.) et al.;** *Deutsche Post AG v EUIPO*; Judgment of 20 February 2018; EU:T:2018:86; Language of the case: EN. The word mark **BEPOST** was sought to be registered as an EUTMR covering the goods and services in Classes 16, 35, 38 and 39. An opposition was filed, inter alia, on the earlier German word mark **POST** (services in Classes 35 and 39) and the EU figurative mark ‘ePOST’ (goods and services in Classes 9, 35, 36, 38, 39, 40, 41 and 42) and the non-registered mark or sign used in the course of trade **POST**. The grounds invoked were based on infringement of Article 8(1)(b) and Articles 8(4) and 8(5) EUTMR. The Opposition Division (OD) dismissed the opposition and the opponent appealed. The Board of Appeal (BoA) dismissed the appeal, insofar as it found that the signs showed significant visual, aural and conceptual differences which were sufficient to rule out a likelihood of confusion, as required by Article 8(1) EUTMR and national law. The possibility of association or the creation of a mental link for the purpose of Article 8(5) EUTMR was rejected taking into account that the German word ‘post’ was a generic term widely used to refer to postal and related services. The opponent filed an action before the General Court (GC) relying on three pleas in law: (i) infringement of Article 8(1)(b) EUTMR, (ii) infringement of Article 8(4) EUTMR and (iii) infringement of Article 8(5) EUTMR. **On the reputation of the earlier national mark POST.** Due to the significant differences between the marks and the weak distinctive character of the common element ‘post’, the relevant public will not make any link between the mark applied for and the earlier national word mark **POST**, since the term ‘post’, in the context of the mark applied for, is likely to be perceived merely as a reference to postal services (para. 115).

**T-85/16; POSITION OF TWO STRIPES ON A SHOE (posit.);** *Shoe Branding Europe BVBA v EUIPO*; Judgment of 1 March 2018; EU:T:2018:109; Language of the case: EN

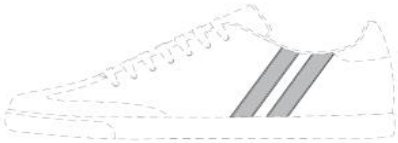
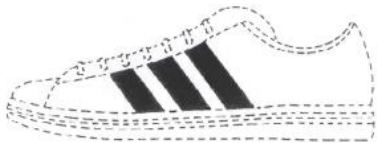
EUTM application	Earlier trade mark
	

The applicant filed an application for registration of the EU trade mark above for the goods in Class 9 (safety footwear for the protection against accidents or injury). An opposition based on the earlier figurative mark above for the goods in Class 25 (footwear) was filed pursuant to Article 8(5) EUTMR. The Opposition Division (OD) rejected the opposition and the opponent appealed the OD’s decision. The Board of Appeal (BoA) upheld the appeal because it considered that given the certain degree of similarity between the marks at issue, the similarity of the goods covered by those trade marks and the high reputation of the earlier mark, there was a likelihood that the relevant public might establish a link between the marks at issue and that the use of the mark applied for could take unfair advantage of the reputation of the earlier mark. The EUTM applicant filed an action before the General Court (GC) relying on two pleas in law: (i) alleging that there is no likelihood of confusion (LOC) on the part of the relevant public and (ii) infringement of Article 8(5) EUTMR. **On the first plea in law.** The BoA did not rely on the existence of LOC within the meaning of Article 8(1)(b) EUTMR, but merely considered it likely that the relevant public



would establish a link between the marks at issue and that unfair advantage of the repute of the earlier mark within the meaning of Article 8(5) EUTMR would occur. So, it must be declared that the contested decision was adopted solely on the basis of the provisions of Article 8(5) EUTMR (para. 27). **On the second plea in law: (i) lack of injury to the repute or to the distinctive character of the earlier mark: (1) First complaint.** Failure to carry out an independent assessment of the existence of injury to the repute or to the distinctive character of the earlier mark: the BoA noted that the earlier mark had a high reputation, that the marks at issue were similar, that the goods at issue were also similar and that there was an overlap in the applicant's and the intervener's groups of clients (para. 74). The BoA considered that there was a high probability that, owing to free-riding, the use of the mark applied for might take unfair advantage of the well-established reputation of the earlier mark (para. 75). Therefore, the BoA did examine whether the use of the mark applied for risked taking unfair advantage of the repute of the earlier mark (para. 76). **(2) Second complaint.** Failure to demonstrate the existence of injury to the repute or to the distinctive character of the earlier mark: the previous complaint alleging the failure by the intervener to demonstrate the existence of an injury referred to in Article 8(5) EUTMR is effective only insofar as it seeks to dispute the existence of a risk of unfair advantage being taken of the repute of the earlier mark. So, there is no need to examine whether the use of the mark applied for is capable of being detrimental to the repute or to the distinctive character of the earlier mark (para. 81). The relevant public for the two categories of goods was the general public in the European Union. The contested goods were also aimed at professionals. The target public for the opponent's goods was made up of the average consumer, reasonably well informed and reasonably observant and circumspect with an average degree of attention (paras 86-87). The BoA considered that the opponent's goods and the goods of the mark applied for were similar (para. 90). The marks at issue are also similar (para. 92). The BoA considered that the earlier mark enjoyed a high reputation and that said reputation was well established (para. 94). The BoA considered that, while the earlier mark had an inherently weak distinctive character, this was abundantly compensated by consistent large-scale use over time of that mark and by its reputation (para. 96). Given the similarity between the marks at issue, the similarity of the goods at issue and the strength of the earlier mark's reputation, there would be a link between the marks at issue in the mind of the relevant public (para. 98). The BoA was right to note that a 'lesser' degree of similarity between the marks at issue could be sufficient for the relevant public to establish a link between them (para. 99). The present dispute is not the first between the applicant and the intervener concerning the applicant's registration of an EUTM consisting of two parallel stripes affixed to a shoe (paras 108-110). The BoA was right to find that the earlier mark enjoyed a high, long-held and well-established reputation and the higher the reputation of the earlier mark, the more likely it is that the use of a similar trade mark will take advantage of the repute of the earlier mark (paras 113-114). The BoA was right to note that given that the goods at issue were similar, it was logical that unfair advantage would be more likely to occur than where the goods were dissimilar (para. 115). So this would strongly increase the probability of unfair advantage (para. 116). The BoA also noted the considerable investment made by the intervener to achieve the reputation enjoyed by the earlier mark (para. 117) and in the event of use of the mark applied for, the positive qualities associated with goods bearing the earlier mark would be transferred to the applicant's goods (para. 118). The intervener argued that the applicant clearly alluded to the earlier mark in using the slogan 'two stripes are enough' (para. 122). That slogan tends to confirm the possibility of unfair advantage being taken, in the future, of the repute of the earlier mark by using the mark applied for (para. 124). Consequently, the alleged coexistence of the marks at issue cannot be regarded as peaceful (para. 126) and that occurrence of injury to the repute of the earlier mark in the future cannot be excluded (para. 127). **(ii) Existence of due cause.** The BoA not only stated that the applicant had failed to provide evidence showing the existence of



due cause, but also specified that the alleged coexistence of the marks at issue was not peaceful (para. 135). The mark applied for must have been used throughout the territory of the European Union but the applicant mentioned coexistence of the marks at issue only on the German market (paras 139-140). Moreover, to constitute due cause, the use of the mark applied for must not have been challenged by the proprietor of the earlier mark with a reputation, which is not the case here (paras 141-142). The proprietor of the mark applied for must have acted in good faith when using the mark applied for, but it is not the case here as evidenced by use of the slogan (paras 143-144).

**T-629/16; DEVICE OF TWO PARALLEL STRIPES (other) / DEVICE OF THREE PARALLEL STRIPES (fig.) et al.**; *Shoe Branding Europe BVBA v EUIPO*; Judgment of 1 March 2018; EU:T:2018:108; Language of the case: EN

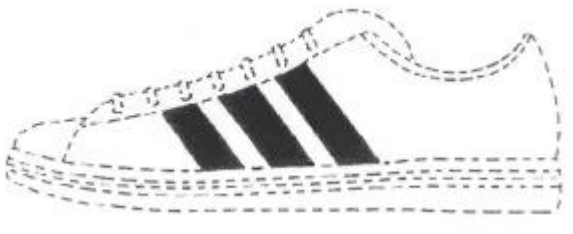
EUTM application	Earlier trade mark
	

The applicant sought to register the figurative mark above as an EUTM for goods in Class 25. An opposition based, inter alia, on the earlier EU figurative mark above, registered for goods in Class 25 was filed and based on Article 8(1)(b) and Article 8(5) EUTMR. The opposition was dismissed, and the opponent filed an appeal, which was dismissed by the Board of Appeal (BoA). It ruled that the trade marks were different overall and there was no likelihood of confusion (LOC) on the part of the relevant public. The opponent filed an action before the General Court (GC), which was upheld, as the GC found that the BoA erred in concluding that there was no similarity between the marks and led to a distorted assessment regarding the LOC. The applicant filed an appeal before the Court of Justice of the European Union (CJ). The CJ dismissed the appeal and the BoA re-examined the appeal brought before it against the OD's decision. It upheld the appeal and allowed the opposition on the basis of Article 8(5) EUTMR. The applicant filed an action before the GC, relying on a single plea in law: infringement of Article 8(5) EUTMR, divided in three parts as to errors of assessment: (i) the evidence of the reputation of the earlier mark, (ii) the existence of damage to the reputation or distinctive character of that trade mark and (iii) the absence of any due cause for the use of the contested mark. **Evidence of reputation of earlier mark.** The submitted evidence, taken as a whole, is sufficient to prove reputation of the earlier mark, and specifically the following: an affidavit about the considerable turnover and the advertising expenditure, surveys on the market share of the undertaking using considerable representative samples (and revealing a high degree of awareness), decisions of national courts (according to which the mark, when affixed to shoes, had a significant reputation or renown), as well as proof on the significant sponsorship activity (paras 70, 72, 73 and 84). The fact that some earlier marks are primarily used in Germany is sufficient, since the territory of Germany may be regarded as a substantial part of the territory of the EU for the proof of reputation of the earlier mark. Furthermore, some of the evidence proves an established reputation of the earlier mark in several other EU countries (paras 81 and 82). **Injury to the reputation or to the distinctive character of the earlier mark.** (i) The BoA fully complied with the annulling judgment (res



judicata) by [correctly] finding an average degree of attention of the relevant public, since the goods were mass-consumption goods, frequently purchased and used by the average EU consumer (paras 104 and 107). (ii) Likewise, the issue of the similarity between the marks was also covered by *res judicata*. In any event, the differences regarding the colour and length of the parallel stripes between the marks cannot rule out the similarity between the marks (paras 112 and 119). (iii) The alleged weakness is compensated by the consistent use of the marks over time on a large scale, leading to at least a normal distinctive character. Moreover, an earlier mark can have a particularly distinctive character because of the reputation it enjoys with the public (paras 132, 135 and 136). (iv) The existence of risk of unfair advantage of the repute of an earlier trade mark suffices to establish risk of detriment (para. 148). (v) Given the average degree of attention, the identity between the goods, the ‘lesser’ similarity of the signs, as well as the normal distinctiveness and the long-held, enduring, significant and global reputation of the earlier mark, the BoA correctly established a link between the marks in the mind of the relevant public (para. 167). The significant marketing efforts on behalf of the proprietor of the earlier mark make coat-tail riding even more tempting in order to benefit from its power of attraction, reputation and prestige (para. 190) The 2007 promotion campaign run in Spain and Portugal (the slogan ‘two stripes are enough’) must be regarded as an attempt to exploit the reputation of the earlier mark (para. 192). **Due cause for use.** In view of the legal dispute in Germany in 1990 and of the previous opposition proceedings brought in 2004, the alleged coexistence on the market cannot be categorised as peaceful (para. 179). In any event, a coexistence of the marks was mentioned only regarding the German market and there was no claim for actual use of the marks consisting of two parallel stripes affixed to a shoe registered in other Member States (para. 208).

♦ [T-2/17](#); **MASSI / MASI et al.**; *SRL v EUIPO*; Judgment of 3 May 2018; EU:T:2018:243; Language of the case: EN. The predecessor in title of the EUTM proprietor was granted registration of the word mark **MASSI** as an EUTM for, inter alia, goods in Class 12. An application for invalidity was filed for those goods pursuant to, inter alia, Article 60(1)(a) EUTMR in conjunction with Article 8(1)(b) EUTMR. The Cancellation Division (CD) dismissed the application for invalidity because related to the same goods, was partly identical as regards the cause of action and subject matter, and concerned parties connected to those involved in application No 5 069 C for a declaration of invalidity. This earlier proceeding was filed by Haro Bicycle Corp. (‘Haro’), and had been rejected by the Office in a decision having the force of *res judicata*. The Board of Appeal (BoA) upheld the invalidity applicant’s appeal and declared the EUTM to be invalid for all the contested goods. It found that the conditions laid down in Article 63(3) EUTMR were not satisfied, as the invalidity applicant was not the same entity as in earlier proceedings No 5 069 C; that the earlier mark was still well known for bicycles and parts thereof in Italy; and that there was a likelihood of confusion (LOC) between the earlier well-known mark **MASSI** and the registered EUTM, **MASSI**. The EUTM proprietor filed an action before the General Court (GC), relying on two pleas in law: (i) infringement of Article 63(3) EUTMR and (ii) infringement of Article 60(1)(a) EUTMR in conjunction with Article 8(2)(c) EUTMR. **Relevant public.** The relevant public is made up not only of cycling professionals and bicycle enthusiasts but also of the general public (paras 42-43). **Earlier well-known mark.** The evidence relating to the earlier mark **MASSI** is insufficient to prove that the invalidity applicant had clearly, convincingly and effectively shown that it was well known in Italy within the meaning of Article 6bis of the Paris Convention for bicycles and parts thereof at the time when the application for registration of the contested mark was filed and on the filing date of the application for a declaration of invalidity (para. 68). In the light of the evidence submitted, it is not possible to ascertain the actual degree of knowledge or recognition of the mark without relying on assumptions, while its status as a well-known





mark cannot be established on the basis of mere assumptions (para. 74). Even though the earlier mark **MASI** might, in the past, have enjoyed well-known status in the domain of cycling, this is nevertheless essentially historical and it has not been shown, by means of sufficient evidence, that such status continued to exist up to the filing date of the application for a declaration of invalidity (para. 76).

**T-662/16; Styriagra / VIAGRA; Gall Pharma GmbH v EUIPO**; Judgment of 3 May 2018; EU:T:2018:242; Language of the case: EN. The applicant sought to register the word mark **STYRIAGRA** for the following goods in Class 29; *preserved, frozen, dried fruits and vegetables, in particular pumpkin seeds*. An opposition was filed against all the abovementioned goods. The opposition was based on the word mark **VIAGRA** covering goods in Class 5 *pharmaceutical and veterinary preparations and substances* and the grounds invoked were those set out in Article 8(1)(b) and Article 8(5) EUTMR. The Opposition Division (OD) rejected the opposition so an appeal was filed against the OD's decision. The Board of Appeal (BoA) upheld the appeal basing its reasoning on Article 8(5) EUTMR. The applicant went on to appeal to the General Court (GC), relying on a single plea in law: infringement of Article 8(5) EUTMR. **Similarity of the marks.** The BoA correctly took into account the overall impression of the signs at issue finding that they were visually similar to a low degree. Despite having five shared letters in the same order, their beginnings and lengths are different (paras 25, 27). The phonetic differences at the beginning of the signs are not sufficient to offset the identical sounds at the end, so there is an average degree of phonetic similarity (para. 31). Conceptually, the signs have no meaning, so there is no impact from any conceptual comparison on the overall impression. The BoA was therefore right in finding that there is a low degree of overall similarity between the marks (para. 32). **Reputation of the earlier mark.** The BoA specified that the reputation of the earlier mark, though extending to the entire population of the EU, nevertheless remains clearly limited to *pharmaceutical preparations for the treatment of male erectile dysfunction* and does not extend to foodstuffs and beverages (para. 43). **Link between the marks.** The BoA was correct to ascertain whether, in the mind of the public concerned, namely the general public of the EU, the mark applied for would call to mind the earlier mark (para. 52). The BoA correctly found that, although the goods at issue are not similar, the aphrodisiacal properties are capable of giving rise to an association between the marks in the mind of the relevant public, despite the differences in nature and purpose of the goods covered by the marks at issue (para. 55). The finding of an association between the marks can be made on the basis of the denominations of the marks (para. 59). **Unfair advantage.** The BoA was fully entitled to conclude that, even though the goods are different, the significant reputation of the earlier mark and the fact that aphrodisiacal effects are sometimes attributed to the natural products in Class 29, it is possible that the general public would establish a link between the two signs and transfer the positive values of the earlier mark to the goods of the mark applied for (para. 79).



♦♦[T-721/16](#); **BeyBeni (fig.) / Ray-Ban (fig.) et al.**; *Luxottica Group SpA v EUIPO*; Judgment of 8 May 2018; EU:T:2018:264; Language of the case: ES

EUTM application	Earlier trade mark
	

The EUTM applicant sought to register the figurative sign above for goods in Classes 9, 14 and 18. An opposition based on the earlier figurative trade mark above was filed pursuant to Article 8(1)(b) and Article 8(5) EUTMR for all the abovementioned goods. The Opposition Division (OD) upheld the opposition pursuant to Article 8(1)(b) EUTMR for all the goods applied for in Classes 14 and 18 and for part of the goods applied for in Class 9. For the remaining Class 9 goods (*apparatus, instruments and cables for electricity, safety, security, protection and signalling devices; devices for treatment using electricity, photovoltaics...*), the opposition was dismissed, pursuant to Articles 8(1)(b) and Article 8(5) EUTMR, as sunglasses and *eyeglass frames* (for which reputation was proved) are not close enough to such goods for the public to establish a link. The applicant appealed the OD’s decision, and the Board of Appeal (BoA) dismissed the appeal. It found that there was only a very small degree of similarity between the signs at issue, and the *sunglasses* and *spectacle frames* did not have sufficient proximity to the goods concerned for a link between the marks at issue to be established in the mind of the relevant public. The EUTM applicant appealed to the General Court (GC) relying on two pleas in law: (i) infringement of Article 70(2) and 94 EUTMR and (ii) infringement of Article 8(5) EUTMR. **Relevant public.** The relevant public is composed of both Spanish professionals and the Spanish general public with at least part of the relevant public possessing an average level of attention (paras 42, 44). So the BoA was wrong to limit its analysis only to professionals (para. 46). **Reputation of the earlier mark.** In light of the evidence submitted by the applicant (sales information, advertising expenditure and market shares) as well as the various references to the success of the mark, the mark enjoyed a high level of recognition among the relevant public for sunglasses and spectacle frames. In addition, the OD considered that the earlier mark had been used extensively and intensively in the relevant market, where it occupies a consolidated position among the leading brands with approximately 25 % of the relevant market share in Spain (para. 47). So the BoA was right to consider that the earlier mark enjoyed a solid reputation in Spain (paras 48-49). **Comparison of the signs for the purposes of Article 8(5) EUTMR.** Even though the BoA was entitled to make a new assessment of the similarity of the conflicting marks, its analysis of the degree of similarity cannot be upheld for the following reasons (para. 53). **Visual comparison.** The marks have a similar structure in that they are both composed of two word elements of similar length, one with six letters and the other seven, several of which are common. Their presentation is also similar, as they are both slightly inclined upward to the right (para. 63). The typographies of the two marks are also very similar as they both resemble handwriting (para. 64). The upper-case letters ‘B’ and ‘R’ are similar and this resemblance is accentuated by their typography. Thus, the first terms of the two marks are strongly similar, especially given the size of the initial letters and the common letter ‘y’ in the two terms (para. 65). Despite the differences — their respective last word elements (‘beni’ and ‘ban’), and the earlier mark being written in black on a white background, while the mark applied for is written in white on a black background







— they are not sufficient to create a general impression which would prevent the consumer making a link between the marks (para. 67). Therefore, because of the similar structure and composition of the conflicting marks, the use of similar handwriting and the similarity of their initial letters ‘r’ and ‘b’, the elements of similarity prevail over the differences. The BoA erred in its assessment of visual similarity, which should have been described as average (para. 68). **Phonetic comparison.** If the public could confuse the initial ‘b’ of the first term of the contested mark with an ‘r’, the same confusion would occur with the initial ‘b’ of the second term. It would not be pronounced ‘rey ben’ or ‘rey beni’, but ‘rey ren’ or ‘rey reni’, expressions that are not phonetically similar to the earlier mark pronounced ‘ray ban’ (para. 71). If the verbal elements are pronounced ‘bey beni’ and ‘ray ban’, there is a clear phonetic difference between the initial syllables ‘b’ and ‘ra’, as well as the elements ‘beni’ and ‘ban’ or ‘eni’ and ‘an’ (para. 72). Even if the pronunciation coincides with the resemblance of the sounds ‘ey’ and ‘ay’ and ‘eni’ and ‘an’, the signs at issue do not include the same number of syllables and are therefore not pronounced with an identical rhythm and cadence (para. 73). So the BoA did not err in finding that the elements of differentiation would prevail over the elements of similarity and that there was a low degree of phonetic similarity between the signs at issue (para. 75). **Conceptual comparison.** As both marks are meaningless in Spanish, the BoA considered that a pertinent comparison could not be made (paras 76-77). The BoA should have inferred from this that the degree of overall similarity should be qualified as low to medium, rather than very low (para. 78). **Existence of a link between the marks in the mind of the public.** An association between the marks cannot be excluded, particularly given the degree of similarity between the marks and the definition of the relevant public as being the general public with an average level of attention (para. 87). The BoA’s assessment is vitiated by errors regarding the relevant public, the degree of similarity of the marks at issue and, consequently, the assessment of the existence of a link between the marks in the public mind (para. 88). These are the relevant factors which make it possible to assess whether the relevant public will establish a link between the conflicting marks and, thus, whether the conditions of Article 8(5) EUTMR are fulfilled. It must therefore be held that the BoA infringed Article 8(5) EUTMR (para. 89).

♦[C-85/16 P](#) and [C-86/16 P](#) (joined cases); **KENZO ESTATE / KENZO**; *Kenzo Tsujimoto v EUIPO*; Judgment of 30 May 2018; EU:C:2018:349; Language of the case: EN. The IR holder designated the EU for two word marks **KENZO ESTATE** covering, respectively, goods in Class 33 and goods and services in Classes 29, 30, 31, 35, 41 and 43. Two oppositions based on the earlier word mark **KENZO**, registered for, inter alia, goods in Classes 3, 18 and 25 were filed by the opponent pursuant to Article 8(5) EUTMR against all the goods and services for which protection was sought. The Opposition Division (OD) dismissed both oppositions. The Board of Appeal (BoA) fully upheld the opponent’s appeal to which Case C-85/16 P refers and partially upheld the appeal to which Case C-86/16 P refers. The IR holder brought two actions before the General Court (GC) for the annulment of the BoA decisions. The GC dismissed both appeals. The IR holder filed two appeals before the Court of Justice of the European Union (CJ) relying on two pleas in law: infringement of Article 95(2) and of Article 8(5) EUTMR. Cases C-85/16 P and C-86/16 P were joined for the purposes of the procedure and of the judgment. The CJ dismissed the appeals. **On the second plea in law.** The CJ endorsed the GC’s findings, according to which the trade marks were similar (para. 59); the word ‘estate’ lacked distinctiveness (para. 61); the GC did not made an error in law by taking into account evidence, concerning the reputation of the earlier mark, submitted out of time, since the GC’s assessment did not relate to the late submission of that evidence (para. 68). Furthermore, the mere fact that a term, ‘kenzo’, corresponds to the appellant’s forename is irrelevant to the issue whether the use of that term constitutes due cause within the meaning of Article 8(5) EUTMR since the weighing of the different interests involved cannot undermine the essential function of the



earlier mark, which is to guarantee the origin of the product (para. 94).

♦ **T-900/16; Dayaday (fig.) / DAYADAY (fig.) et al.; Casual Dreams, S.L.U v EUIPO;** Judgment of 1 June 2018; EU:T:2018:327; Language of the case: ES

EUTM application	Earlier trade marks
	

The applicant sought to register the figurative mark above as an EUTM for goods in Classes 9, 16 and 24. An opposition based on, inter alia, the earlier figurative marks above, registered for goods in Classes 18 and 35, was filed pursuant to Article 8(1)(b) and Article 8(5) EUTMR. The OD dismissed the opposition. Upon the opponent’s appeal, the Board of Appeal (BoA) partially upheld the appeal with regard to the goods for which protection is sought in Classes 16 and 24 because it found that there was likelihood of confusion. With regard to Article 8(5) EUTMR, the Board concluded that the opponent had not argued or proved that the use of the mark would lead to unfair advantage or detriment to the distinctive character or reputation of the earlier marks. The opponent appealed to the General Court (GC) relying on two pleas in law: (i) infringement of Article 8(5) EUTMR and (ii) infringement of Article 8(1)(b) EUTMR. The reputation of the earlier trade mark, and, in particular, the strength of that reputation is one of the factors to be taken into account in the assessment both of whether there is an association on the part of the public between the conflicting signs and whether there is a risk that one of the three types of injury may occur (risk that the use without due cause of the contested trade mark would take unfair advantage of, or be detrimental to, the distinctive character or the repute of the earlier trade mark) (para. 30). Though the opponent did not refer expressly to the exceptionally strong reputation, it did mention that the sign enjoys considerable reputation before the OD, and huge success and broad acknowledgement before the BoA. Therefore, the BoA should have ruled on the reputation of the earlier marks, and, specifically, their importance (para. 35). Although the opponent had adduced evidence that allowed the assessment of the reputation of the earlier marks, the BoA did not examine it or reach a conclusion regarding its existence, nor did it formulate a hypothesis based on the acknowledgement of a reputation with a specific level of strength (paras 36-37). Since the importance of the reputation of the earlier mark was not assessed, the GC cannot decide on this question. The GC cannot replace the Office in the exercise of the powers conferred on the latter by the regulations. Therefore, the BoA infringed Article 8(5) EUTMR (para. 38).

**T-111/16; THE RICH PRADA / PRADA (fig.); Prada SA v EUIPO;** Judgment of 5 June 2018; EU:T:2018:328; Language of the case: EN. The applicant sought to register the word mark **THE RICH PRADA** as an EUTM for goods and services in Classes 30, 32, 35, 36, 37, 41, 42, 43, 44 and 45. An opposition based on, inter alia, various national word and figurative marks, **PRADA**, for goods and services in Classes 18, 25 and 35 was filed pursuant to Article 8(1)(b) and Article 8(5) EUTMR. The Opposition Division (OD) partially upheld the opposition for certain services in Classes 35, 41, 43 and 44. Both parties





appealed. The Board of Appeal (BoA) dismissed the applicant's appeal and partially upheld the opponent's appeal with regard to a number of services in Classes 35 and 41. It found that, due to the similarity between the marks, there would be a risk of unfair advantage being taken of the distinctive character or the repute of the earlier trade marks within the meaning of Article 8(5) EUTMR for the services closely linked to the fashion sector. The opponent appealed to the General Court (GC) for the annulment in part of the BoA decision relying on two pleas in law: (i) infringement of Article 8(1)(b), and (ii) infringement of Article 8(5) EUTMR. **Dissimilarity of the goods and services.** The opponent failed to demonstrate that the public would be able to establish a plausible link with the different subcategories of goods, even those furthest removed from the sectors of fashion and luxury items to which the earlier marks refer (paras 47-50). **Unfair advantage of the repute or of the distinctive character.** Similarly, it is not sufficient to refer to the concept of brand extension and to generically submit that consumers will feel more attracted to the later marks due to their link with the reputed earlier mark; on the contrary, the opponent must submit specific, convincing arguments relating to the transfer of the positive values and image of the earlier marks to a later mark covering goods and services of a different nature (paras 54, 55). **Detriment to the distinctive character.** The opponent also failed to submit arguments and evidence that demonstrate a change in the economic behaviour of the average consumer or a serious likelihood that such a change will occur in the future (paras 55, 56).

♦[T-112/17](#); **NEW ORLEANS PELICANS (fig.) / Pelikan et al.**; *Pelikan Vertriebsgesellschaft mbH & Co. KG v EUIPO*; Judgment of 12 September 2018; EU:T:2018:528; Language of the case: EN. The applicant sought to register the figurative mark **NEW ORLEANS PELICANS** as an EUTM for goods and services in Classes 9, 16, 18, 25, 28 and 41. An opposition based on, inter alia, two earlier word marks, **Pelikan**; registered for, inter alia, goods and services in Classes 9, 16, 18, 25, 28 and 41 respectively, was filed pursuant to Article 8(1)(b) and Article 8(5) EUTMR. The Opposition Division (OD) upheld the opposition for all the contested goods and services, finding that the goods and services of the earlier word marks were identical and similar and that the signs were similar. The Board of Appeal (BoA) upheld the applicant's appeal due to the differences between the signs and the fact that the opponent had failed to submit a coherent line of argument as to why use of the mark applied for would take unfair advantage of, or be detrimental to, the distinctive character or repute of the earlier mark. The opponent appealed to the General Court (GC), relying on eight pleas in law, alleging, in the first seven: infringement of Article 8(1)(b) EUTMR and, in the final plea, infringement of Article 8(5) EUTMR. **Reputation.** As the signs are dissimilar, it is not necessary to consider the consequence that a potential similarity between the signs could have with regard to Article 8(5) EUTMR, even if the applicant were to put forward an argument on that point (para. 73).



♦ [T-62/16](#); **PUMA (fig.) / PUMA (fig.) et al.**; *Puma SE v EUIPO*; Judgment of 26 September 2018; EU:T:2018:604; Language of the case: EN



EUTM application	Earlier trade marks
	

The applicant sought to register the figurative mark above as an EUTM for *lathes; CNC (computer numerical control) lathes; machining centres; turning centre; electric discharge machine* in Class 7. An opposition based on the earlier figurative marks above, registered for goods in Classes 7, 18, 25 and 28, respectively, was filed pursuant to Article 8(1)(b) and Article 8(5) EUTMR. The Opposition Division (OD) dismissed the opposition, finding that the goods covered by the conflicting marks were not similar and that one of the conditions for the application of Article 8(5) EUTMR was not satisfied, namely that the opponent had not proved the alleged reputation of the earlier marks. The opponent appealed, which the Board of Appeal (BoA) dismissed, finding that the goods were not similar and that, despite the very high degree of similarity of the marks, and the assumption that the reputation of the earlier marks was established, the relevant public would not establish any link whatsoever between them given the entirely different nature of the goods covered and the sections of the public targeted by each of the marks, together with their low degree of distinctiveness. Finally, it found that the appellant had not proved that the use of the mark applied for would take unfair advantage of the distinctive character or reputation of the earlier marks, or would be detrimental to them. The opponent filed an action before the General Court (GC), relying on one sole plea in law: infringement of Article 8(5) EUTMR. **Relevant public.** The court confirms the definition of the relevant sections of the public that are the target of the goods covered by each of the marks. The BoA was correct in concluding that the sections of the public were different: the target public for the contested goods consisting of highly specialised technical professionals, while the public targeted by the earlier marks was the public at large (paras 33, 50). The BoA also took into account the possibility of an overlap between the relevant sections of the public concerned (paras 45-46) **Similarity of the marks.** The marks are highly similar as rightly held by the BoA (para. 56). **Reputation of the earlier marks.** The BoA assumed that the strong reputation of the earlier marks existed, without examining whether the opponent had sufficiently established the reputation of these earlier marks or assessing the strength of that reputation. It thus failed to take due account of the level of the strength of the reputation claimed (paras 69-70). This basic assumption upon which the BoA based its assessment of whether the injury referred to in Article 8(5) EUTMR existed, is therefore erroneous; the opponent had in fact claimed that the reputation of the earlier marks was such that it went beyond the public who were the target of the goods designated by those marks and, therefore, in essence, that it could extend to the professional public targeted by the mark applied for (paras 70-71). **The distinctive character of the earlier marks.** The BoA erred in its assessment relating to the low degree of distinctive character of the earlier marks, as it did not establish that the goods designated by them might possess qualities of strength and power or that the term ‘puma’, therefore, alluded to the characteristics of those goods (paras 77-78). The BoA also erred in



its conclusion that there was no link between the marks in the mind of the relevant public, as it did not follow a proper assessment of all the relevant factors: first, it did not properly take into account the degree of reputation relied on by the opponent and, secondly, it did not properly assess the degree of inherent distinctive character of the earlier marks (paras 85, 91). Therefore, the finding of an association with the earlier marks could, nevertheless, still have been possible had the BoA correctly assessed the degree of reputation. Even if the sections of the public that are the target of the goods covered by the conflicting marks do not overlap, given that the goods concerned are different, it is possible that a connection between the marks may be established due to the high degree of similarity between them (para. 89). Article 8(5) EUTMR expressly envisages a situation in which an opposition is filed against an application for registration of an EU mark for goods or services that are not similar to those designated by an earlier mark; therefore, the dissimilarity between the goods designated respectively by the marks is not sufficient for excluding the existence of a link between those marks (paras 98-100). **Conclusion.** Due to the errors committed by the BoA in its assessment of whether there is a link between the marks, the contested decision must be annulled. The BoA will have to re-examine the case to reach a definitive conclusion, firstly, with regard to the existence of the reputation of the earlier trade marks and, perhaps, how strong that reputation is, and, secondly, with regard to the degree of distinctive character of the earlier marks (paras 104-105). If it reaches a definitive conclusion that there is a link between the marks, it will have to examine whether the opponent has sufficiently established the existence of one of the injuries referred to in Article 8(5) EUTMR, bearing in mind the degree of reputation and the distinctive character of the earlier marks. The stronger the earlier mark’s distinctive character and reputation are, the easier it will be to accept that harm has been caused to the earlier mark for the purposes of Article 8(5) EUTMR (para. 106).

♦[T-581/17](#); **DEVICE OF FOUR CROSSING LINES (fig.) / DEVICE OF FOUR CROSSING LINES (fig.) et al.**; *Asics Corporation v EUIPO*; Judgment 16 October 2018; EU:T:2018:685; Language of the case: EN

EUTM application	Earlier trade mark
	

The applicant sought to register the figurative mark above as an EUTM for goods in Classes 18, 24 and 25. An opposition based on the earlier EU figurative mark above (for goods in Class 18) and an earlier Spanish figurative mark (for goods in Class 25) was filed pursuant to Article 8(1)(b) and Article 8(5) EUTMR. The Opposition Division (OD) dismissed the opposition, so the opponent filed an appeal. The Board of Appeal (BoA) dismissed the appeal, finding that the signs gave an overall different impression. It added that, as the signs were purely figurative, no phonetic comparison was possible and that the conceptual comparison remained neutral. The opponent filed an action before the General Court (GC), relying on five pleas in law: (i) infringement of Article 95(1) EUTMR, as the BoA committed a manifest error in the assessment of the facts and an infringement of essential procedural requirements during the comparison of the signs, (ii) infringement of the obligation of the BoA to review the legality of the OD’s decision, (iii) infringement of Article 94 EUTMR as the BoA infringed its obligation to state reasons, (iv) infringement of Article 8(1)(b) EUTMR, and



(v) infringement of Article 8(5) EUTMR. **Relevant public and comparison of goods.** The relevant public consists of consumers in the EU (para. 38) and the goods are identical. **Comparison of the signs.** Even if the consumer does not recall details such as the size or thickness of the lines, the overall impression between the thick lines and curves forming a letter 'x' superimposed on a character " on the one hand, and the thin straight lines that can be perceived as the number sign, '#', inclined backwards to 45 degrees on the other, is so different that the consumer will not make a connection between the signs solely on the basis that they are both composed of parallel lines crossing two other, longer lines (para. 46). The overall impression given by the marks was different, and therefore, there is no visual similarity (para. 47). The signs are figurative marks without any word elements, therefore, it is not possible to compare the signs phonetically. The conceptual comparison remains 'neutral', since none of the graphic forms have a conceptual content (para. 48). **No LOC.** Given the lack of similarity between the signs, there is no LOC (paras 53-54). **Article 8(5) EUTMR.** The first of the three cumulative conditions for the application of Article 8(5), namely, the identity or similarity of the signs, is not fulfilled (paras 63-64).

♦[T-548/17](#); **ANOKHI (fig.) / Kipling (fig.) et al.**; *VF International Sagl v EUIPO*; Judgment of 16 October 2018; EU:T:2018:686; Language of the case: EN. An application for registration of an EU trade mark was filed for the figurative sign 'ANHOKI' for goods in Classes 9, 14, 18 and 25. The applicant filed an opposition based on earlier EU trade marks, pursuant to Articles 8(1)(b) EUTMR and Article 8(5) EUTMR. The Opposition Division (OD) rejected the opposition in its entirety on the grounds that, although the signs were similar, they were not sufficiently so as to lead to a likelihood of confusion (LOC) in the absence of proof of enhanced distinctiveness of the earlier marks, even in relation to identical goods. In the absence of convincing proof of reputation, the opposition was also dismissed under Article 8(5) EUTMR. On appeal against the OD's decision, the Board of Appeal (BoA) found that the marks at issue were not visually, phonetically or conceptually similar, and thus, the opposition had to be dismissed under Article 8(1)(b) EUTMR without a global assessment of the LOC. As regards Article 8(5) EUTMR, the BoA confirmed the OD's findings that reputation was not proven. The opponent filed an action before the General Court (GC), relying on three pleas in law: (i) infringement of Article 8(1)(b) EUTMR, (ii) infringement of Article 8(5) EUTMR and (iii) infringement of Article 85(1) EUTMR. The GC annulled the BoA's decision in accordance with the following reasoning. **Reputation.** Although upholding the plea under Article 8(1)(b) EUTMR led to the annulment of the BoA's decision, the GC continued with the assessment of the plea under Article 8(5) EUTMR. The evidence predating the filing of the contested mark (catalogues and press clippings) showed only very rare examples of the earlier marks appearing on the relevant goods. In fact, most of this evidence showed a different sign to the earlier marks (a round sign containing the word 'KIPLING' without the representation of a monkey) and pictures and references to a furry figure that differed significantly from the silhouette of the slender, long-tailed monkey present in the earlier marks. Documents showing a concurrent and significant quantitative use of several signs that are different from the earlier marks, in order to designate the opponent's goods, are equivocal and have little value when it comes to showing that those earlier marks have acquired a reputation. As such, that evidence could not corroborate the affidavit of a senior executive officer of the opponent's company. It has not been demonstrated that the turnover figures and advertising expenditure concerned goods only sold under the earlier marks and not under other signs. Furthermore, the mere statement that the sales in question were achieved in the European Union does not give any indication, in the absence of information on the market share, as to whether the earlier marks are known by a significant part of the public in the European Union and in a substantial part of the territory of the European Union. The Wikipedia extract dedicated to the Kipling brand lacks certainty, since it is based on a collective, internet-based



encyclopedia, the content of which may be amended at any time and by any contributor. In the absence of a survey or a market study, the photographs of celebrities sporting the bags marketed by the opponent are not sufficient to objectively establish the impact that the reputation of the mark has on the general public. The evidence of advertising in conventional and social media demonstrates certain media visibility, however, given the ambiguity resulting from the significant use of signs different from the earlier marks, this evidence is too fragmentary and insufficient to demonstrate the reputation of the earlier marks. Consequently, the GC endorsed the BoA's finding that the opponent failed to establish, to the requisite legal standard, the reputation of the earlier marks and rejected the plea invoked under Article 8(5) EUTMR (paras 93-133).

◆ [T-8/17](#); **GOLDEN BALLS / BALLON D'OR et al.**; *Golden Balls Ltd v EUIPO*; Judgment of 17 October 2018; EU:T:2018:692; Language of the case: FR. The applicant sought to register the word mark **GOLDEN BALLS** as an EUTM for goods and services in Classes 9, 28 and 41. An opposition based on the earlier word mark **BALLON D'OR**, registered for goods and services in Classes 9, 28 and 41, was filed pursuant to Article 8(1)(b) EUTMR and Article 8(5) EUTMR. The Opposition Division (OD) rejected the opposition in its entirety. The opponent filed an appeal. The Board of Appeal (BoA) annulled the OD's decision, finding likelihood of confusion (LOC) for all of the goods except *apparatus and instruments for conducting, switching, transforming, accumulating, regulating or controlling electricity* in Class 9. Grounds under Article 8(5) EUTMR were not examined. The applicant filed an action with the General Court (GC) pursuant to Article 8(1)(b) EUTMR and the opponent filed a cross-claim pursuant to Article 8(5) EUTMR. In T-448/11, the GC upheld the applicant's action and rejected the opponent's cross-claim. The opponent appealed to the Court of Justice (CJ). In C-581/13 P & C-582/13 P, the CJ annulled the GC's judgment insofar as it concerned the dismissal of the opponent's cross-claim. The case was remitted to the BoA, which noted that the specification of the trade mark application had been restricted by deleting *apparatus and instruments for conducting, switching, transforming, accumulating, regulating or controlling electricity* in Class 9 and that the refusal of the opposition based on Article 8(1)(b) EUTMR was already final. It therefore remitted the case to the OD for examination on the grounds of Article 8(5) EUTMR. The OD partially upheld the opposition on Article 8(5) EUTMR for some of the goods and services. The applicant also appealed against this decision, insofar as it rejected the trade mark application. The opponent filed a cross-appeal, seeking revision of the OD's decision pursuant to Article 8(3) of Regulation (EC) No 216/96 for the goods and services that had not been rejected. The BoA dismissed the applicant's appeal, upheld the opponent's cross-appeal and rejected the EUTM application in its entirety. The applicant filed an action with the GC, relying on four pleas in law: (i) infringement by the BoA of the authority of res judicata, (ii) that the BoA had exceeded the subject matter of the appeal before it, thus infringing the applicant's right of defence, (iii) that the BoA failed to take into account developments after the filing of the EUTM application and (iv) infringement of Article 8(5) EUTMR. **Comparison of the signs.** The BoA was bound by the GC's findings in T-448/11: there is no visual or phonetic similarity between the signs at issue and, at most, a weak conceptual similarity (paras 88, 92). **Reputation.** The use of 'Ballon d'or' together with 'FIFA' and 'France Football' has no decisive consequence on the appreciation of the reputation of the earlier mark 'Ballon d'or' (paras 99-101). The earlier mark enjoys a very strong reputation, particularly in France, for *competitions in sports matters, organisation of sports competitions and awarding of trophies* included in Class 41 (para. 103). **The link.** The BoA concluded that all goods and services for which protection was sought were sufficiently close to the services for which the earlier trade mark was renowned because they were all likely to relate to a sporting theme. The BoA failed to make a global assessment of the link between the marks for the goods and services not rejected by the OD decision (paras 124-125). The GC explicitly



takes a position against the existence of a link for those goods and services rejected by the BoA (paras 133, 150). **Unfair advantage.** The GC confirms the risk of the applicant taking unfair advantage of the reputation of the earlier mark for the goods and services already rejected by the OD (paras 139, 141, 142). **Tarnishment.** The BoA did not analyse the ground of opposition based on tarnishment and the GC cannot substitute the BoA. However, the GC notes that the vulgar connotation of ‘balls’ in English is only one of its possible meanings and that it simply means ‘several balls’ in standard language (para. 151).

♦[T-372/17](#); **LV POWER ENERGY DRINK (fig.) / LV (fig.);** *Louis Vuitton Malletier v EUIPO*; Judgment of 29 November 2018; EU:T:2018:851; Language of the case: EN

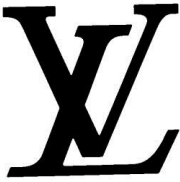

EUTM application	Earlier trade mark
	

The applicant sought to register the figurative mark above as an EUTM for goods and services in Classes 32, 35 and 43. An invalidity application was filed for all the abovementioned goods and services pursuant to Article 60(1)(a) EUTMR in conjunction with Article 8(5) EUTMR, based on the earlier figurative mark above. The Cancellation Division (CD) dismissed the invalidity application. The invalidity applicant filed an appeal against the CD’s decision and the Board of Appeal (BoA) dismissed the appeal. The invalidity applicant filed an action with the General Court (GC), relying on two pleas in law: (i) infringement of Article 8(5) EUTMR and (ii) infringement of the principle of legal certainty and infringement of Article 94 EUTMR. **Visual comparison.** The combination of the letters ‘l’ and ‘v’ is the sole element of the earlier mark and the dominant element of the contested mark, while the element ‘power energy drink’ will attract the attention of the relevant public less. Contrary to the BoA’s finding, the overall impressions created by the marks at issue do not differ significantly and the marks must be considered to have at least an average degree of visual similarity (para. 80). **Phonetic comparison.** For at least part of the relevant public, the letters ‘l’ and ‘v’ will be pronounced in the same order and first, so there is, contrary to the findings of the BoA, an average phonetic similarity between the marks at the very least (paras 84-85). **Conceptual comparison.** The marks at issue are conceptually dissimilar due to the presence of the word element ‘power energy drink’ (para. 87). Even assuming they are conceptually dissimilar, overall, the signs are similar to an average degree, contrary to the BoA’s assessment (para. 88). **Reputation.** The BoA erred in finding the reputation of the earlier mark could not be proved in the documents produced, with the exception of the brand rankings and the website Wikipedia, on account of the mere fact that it appeared as part of a pattern (the ‘Monogram canvas’) or together with the word mark **LOUIS VUITTON** (para. 95). The BoA conducted an incomplete assessment of the reputation of the earlier mark and, in addition, distorted the clear sense of some of the evidence (para. 100). The court finds that the BoA’s assessment regarding the application of Article 8(5) EUTMR is vitiated by several errors or lacunae, relating to the comparison of the signs at issue, the existence of the reputation of the earlier mark and the strength of that reputation (para. 112).





♦ [T-373/17](#); **LV BET ZAKŁADY BUKMACHERSKIE (fig.) / LV (fig.)**; *Louis Vuitton Malletier v EUIPO*; Judgment of 29 November 2018; EU:T:2018:850; Language of the case: EN

EUTM application	Earlier trade mark
	

The applicant sought to register the figurative mark above as an EUTM for goods and services in Classes 28, 35 and 41. An opposition based on the earlier figurative mark above was filed for all the abovementioned goods and services pursuant to Article 8(1)(b) and Article 8(5) EUTMR. The Opposition Division (OD) upheld the opposition. It found that the signs had a low degree of visual similarity, that they had a low, average or very high degree of phonetic similarity, depending on the part of the relevant public taken into consideration, and that they were conceptually dissimilar. The OD also found that the reputation of the earlier mark was proven in the EU for a significant part of the goods it covered in Classes 18 and 25 and that an association between the marks was possible. Lastly, it considered that the mark applied for was likely to take unfair advantage of the reputation and the distinctive character of the earlier mark. The applicant filed an appeal. The Board of Appeal (BoA) upheld the appeal, annulled the OD's decision and rejected the opposition in its entirety. The opponent filed an action with the General Court (GC), relying on two pleas in law: (i) infringement of Article 8(5) EUTMR and (ii) infringement of the principle of legal certainty and infringement of Article 94 EUTMR. **Visual comparison.** The combination of the letters 'l' and 'v' is the sole element of the earlier mark and the dominant element of the contested mark applied for, whereas the other elements of the mark applied for will play only a secondary role or will attract the attention of the consumer less. Contrary to the BoA's finding, the overall impressions created by the marks at issue do not differ significantly and the marks must be considered to have at least an average degree of visual similarity (para. 81). **Phonetic comparison.** Although the pronunciation of the marks at issue differs due to the pronunciation of the word 'bet', which is less distinctive for at least part of the relevant public than the letters 'l' and 'v' for the contested goods and services, there is, contrary to the findings of the BoA, a phonetic similarity between those marks, which must be characterised as average at the very least (para. 85). **Conceptual comparison.** The marks at issue are conceptually dissimilar due to the presence of the word element 'bet' (para. 87). Even assuming they are conceptually dissimilar, overall, the signs are similar to an average degree, contrary to the BoA's assessment (para. 88). **Reputation.** The BoA erred in finding the reputation of the earlier mark could not be proved in the documents produced, with the exception of the brand rankings and the website Wikipedia, on account of the mere fact that it appeared as part of a pattern (the 'Monogram canvas') or together with the word mark **LOUIS VUITTON** (para. 95). The BoA conducted an incomplete assessment of the reputation of the earlier mark and, in addition, distorted the clear sense of some of the evidence (para. 100). The court finds that the BoA's assessment regarding the application of Article 8(5) EUTMR is vitiated by several errors or lacunae, relating to the comparison of the signs at issue, the existence of the reputation of



the earlier mark and the strength of that reputation (para. 112).

♦[T-274/17](#); **MONSTER DIP (fig.) / MONSTER ENERGY (fig.) et al.**; *Monster Energy Company v EUIPO*; Judgment of 13 December 2018; EU:T:2018:928; Language of the case: EN

EUTM application	Earlier rights
	 <p data-bbox="927 815 1209 875">MONSTER ENERGY MONSTER</p> <p data-bbox="770 882 1362 911">UK non-registered TM 'MONSTER ENERGY'</p>

The applicant sought to register the figurative mark above as an EUTM for goods and services in Classes 2, 37 and 40. An opposition based on the EU word marks **MONSTER ENERGY** and **MONSTER**, the EU figurative mark (above) and the unregistered UK mark **MONSTER ENERGY**, inter alia, was filed pursuant to Article 8(1)(b) EUTMR, Article 8(4) EUTMR and Article 8(5) EUTMR. The Opposition Division (OD) dismissed the opposition. The opponent appealed, which the Board of Appeal (BoA) dismissed, finding that the goods and services were dissimilar. It stated that reputation had only been established for the earlier EU figurative mark **MONSTER ENERGY** and that it would only, therefore, take that earlier mark into account. It found that the marks were similar 'to at least a certain extent', but taking all the circumstances of the case into account, there was no link between the marks. The opponent filed an action before the General Court (GC), relying on five pleas in law: (i) the BoA wrongly held that the goods and services were different, (ii) the BoA wrongly rejected the existence of a conceptual similarity between the contested mark and the earlier EU figurative mark **MONSTER ENERGY**, (iii) the BoA wrongly held that the relevant public would not establish a link between those marks, (iv) the BoA wrongly concluded that the distinctive character of the earlier marks was not undermined, (v) the BoA erred in failing to analyse the application of Article 8(4) EUTMR. **Article 8(5) EUTMR**. The condition of reputation was met only as regards the earlier EU figurative mark **MONSTER ENERGY** and only regarding non-alcoholic beverages (para. 60). As the degree of similarity between the marks was not high and the goods and services were dissimilar, the BoA correctly found that, despite the strong reputation of the earlier mark for non-alcoholic drinks, the relevant public would not establish any link between the earlier EU figurative mark **MONSTER ENERGY** and the contested mark (para. 83).

## F. Other issues

♦[T-71/17](#); **FRANCE.COM (fig.) / France (fig.)**; *France.com, Inc. v EUIPO*; Judgment of 26 June 2018; EU:T:2018:381; Language of the case: EN. The EUTM applicant sought to register the figurative sign 'FRANCE.COM' for the services in Classes 35, 39 and 41. An opposition based on the earlier trade mark 'France' was filed pursuant to Article 8(1)(b) EUTMR. The Opposition Division (OD) rejected the opposition. The opponent appealed



against the OD's decision which was annulled by the Board of Appeal (BoA). It found that the services for which protection was sought were aimed at the general public and professionals, that the level of attention of the relevant public ranged from average to high and that the likelihood of confusion (LOC) should be assessed in the European Union. The BoA upheld the OD's finding that the services were in part identical and in part similar. It also found that the signs had an average degree of visual similarity and were phonetically and conceptually identical, so they were highly similar overall. A LOC within the meaning of Article 8(1)(b) EUTMR could not be ruled out. The EUTM applicant appealed to the General Court (GC) relying on two pleas in law: (i) infringement of Article 8(2) and 46(1) EUTMR, infringement of Article 2(2)(b) and Article 5 EUTMDR and (ii) infringement of Article 8(1)(b) EUTMR. **The first plea in law.** The only rights to be taken into consideration in the opposition proceedings in question are the mark applied for and the earlier mark (para. 32). However, that does not mean that a mark registered in accordance with the 'first to file' principle is automatically protected. On the contrary, that protection requires constant vigilance on the part of the first person to file the mark (para. 35). If the applicant holds rights that predate the EU mark on which the intervener relies, it is for the applicant to seek protection of those rights by means of opposition or cancellation proceedings. As long as the earlier EU mark on which the intervener relies is in fact protected, the existence of earlier rights is irrelevant where an EU trade mark application is opposed (para. 36). Consequently, any decision by national courts concerning EU figurative marks is irrelevant to the present dispute (para. 37). Accordingly, as the first plea in law is unfounded, it must be rejected (para. 39).

♦[T-817/16](#); **OV (fig.) / V (fig.)**; *Vans, Inc. v EUIPO*; Judgment of 6 December 2018; EU:T:2018:880; Language of the case: DE. The applicant sought to register the figurative mark 'V' as an EUTM for goods and services in Classes 18 and 25. An opposition based on the earlier figurative mark 'V', registered for goods and services in Classes 18 and 25, was filed pursuant to Article 8(1)(b) EUTMR. The existence of the earlier mark being an international registration was shown by an excerpt from the EUIPO's TMview database. The Opposition Division (OD) partially upheld the opposition. The applicant appealed and, in its observations, the opponent filed a cross-appeal. The Board of Appeal (BoA) dismissed the appeal in its entirety and upheld the cross-appeal partially. The applicant filed an action before the General Court (GC), relying on three pleas in law: (i) infringement of Article 7(2) and (4) and Article 8(1) and (7) EUTMDR, (ii) infringement of Article 8(1)(b) EUTMR and (iii) infringement of Article 68(1), first sentence, Article 70(2) and Article 94(1) EUTMR and of the principle of prohibition of *reformatio in peius* and of the right to be heard. **Proof of the existence, validity and scope of the earlier international registration.** When Article 7(2)(a)(ii) EUTMDR provides that the evidence of the existence, validity and scope of protection of its earlier mark should be provided by the opponent by submitting a copy of the relevant registration certificate '(...) or equivalent documents from the administration by which the trade mark was registered', it must be understood that such a provision does not preclude that access to the documents originating from the competent authority is made through a computer system managed by the Office but involving the competent authority in transmitting and updating the relevant information (para. 37). Such is the case with the TMview database, which is an EUIPO-managed IT tool to which other trade mark offices, including WIPO, contribute. This tool collects and provides access to the trade mark applications and registrations of participating trade mark offices. The information is provided by the trade mark offices who own the content and are responsible for the daily updates (para. 38). It follows that the submission of an excerpt from the TMview database, if it contains all relevant information, in particular the list of goods or services covered, with regard to international registrations designating the EU, constitutes a document equivalent to a registration certificate originating from WIPO within the meaning of Article 7(2)(a)(ii)



EUTMDR (para. 41). The first plea in law must therefore be rejected as unfounded (para. 46).

♦ [T-848/16](#); **V (fig.) / V (fig.) et al.**; *Deichmann SE v EUIPO*; Judgment of 6 December 2018; EU:T:2018:884; Language of the case: DE. The applicant sought to register the figurative mark 'V' as an EUTM for goods and services in Classes 18 and 25. An opposition based on the earlier figurative marks 'V' (international registration (IR) No 937 479, IR No 937 526 and IR No 937 528, all designating the EU), registered for goods and services in Classes 18, 25 and 28, was filed pursuant to Article 8(1)(b) EUTMR. The Opposition Division dismissed the opposition. The applicant filed an appeal. The Board of Appeal (BoA) dismissed the appeal finding that there was no likelihood of confusion with regard to IR No 937 479 and IR No 937 526. The existence of the earlier trade mark IR No 937 528 had not been established since the BoA did not find an excerpt from the TMview database to be sufficient proof. The applicant filed an action with the General Court (GC), relying on three pleas in law: (i) infringement of Article 189(2) EUTMR, (ii) infringement of Article 7(2)(a)(ii) EUTMDR and (4) and Article 8 EUTMDR and (iii) infringement of the principles of the protection of legitimate expectations, legal certainty, good administration, equal treatment and non-retroactivity, having regard in particular to the decision-making practice of the Office and the content of the Office's examination guidelines. **Proof of the existence, validity and scope of an earlier international registration.** It follows from Article 7(2)(a) EUTMDR, which is applicable to IRs designating the EU in accordance with Article 182 EUTMR, that the opponent must prove the filing or registration of the earlier mark, where the opposition is based on a mark other than an EUTM. The need to provide such evidence also relates to IRs designating the EU since the administration by which the trade mark was registered is WIPO and not the EUIPO (para. 34). The BoA therefore rightly concluded that the opponent had to provide proof of the protection of the earlier IRs designating the European Union (IR No 937 479 and IR No 937 526). **Proof of the existence, validity and scope of the earlier international registration (TMview).** While Article 7(2)(a)(ii) EUTMDR provides that the evidence of the existence, validity and scope of protection of the earlier mark must be provided by the opponent by submitting a copy of the relevant registration certificate 'or equivalent documents from the administration by which the trade mark was registered', it must be understood that said provision does not preclude the documents originating from the competent authority being accessed through a computer system managed by the Office but involving the competent authority in transmitting and updating the relevant information (para. 59). Such is the case with the TMview database, which is a tool managed by the Office but to which other trade mark offices, including WIPO, contribute. This tool collects and allows access to the trade mark applications and registrations of participating trade mark offices. The information is provided by the trade mark offices who own the content and are responsible for the daily updates (para. 60). It follows that the submission of an excerpt from the TMview database, if it contains all relevant information, in particular the list of goods or services covered, with regard to international registrations designating the EU, constitutes a document equivalent to a registration certificate originating from WIPO within the meaning of Article 7(2)(a)(ii) EUTMDR (para. 70). The second plea in law must therefore be upheld (para. 74). Since the second plea in law is well founded, the contested decision must be annulled without it being necessary to examine the third ground of appeal, alleging infringement of the principles of the protection of legitimate expectations, legal certainty, good administration, equal treatment and non-retroactivity (para. 75).



#### IV. PROOF OF USE

♦[T-68/16](#); **DEVICE OF A CROSS ON A SPORT SHOE SIDE (fig.)**; *Deichmann SE v EUIPO*; Judgment of 17 January 2018; EU:T:2018:7; Language of the case: EN. The figurative mark ‘DEVICE OF A CROSS ON A SPORT SHOE SIDE (fig.)’ was registered as an EUTM for goods in Class 25 (*sports footwear*). An application for revocation was filed pursuant to Article 58(1)(a) EUTMR. The Cancellation Division (CD) upheld the application for revocation insofar as it found that the evidence provided demonstrated use of the mark in a form that altered the distinctive character of the mark as registered. Upon appeal, the Board of Appeal (BoA) annulled the CD’s decision and rejected the application for revocation. It held that the evidence adduced showed genuine use of the mark and that the differences between the mark as used and the contested mark were negligible. The revocation applicant filed an action before the General Court (GC) relying on three pleas in law: (i) infringement of Article 58(1)(a) EUTMR, inasmuch as the BoA wrongly assessed the subject matter of the contested mark, by holding that it was irrelevant whether the mark was a figurative mark or a position mark; (ii) infringement of Articles 58(1) and 18(1) EUTMR, inasmuch as, in order to determine whether the mark was used in its registered form or in a form that did not alter its distinctive character, the BoA merely compared a part of the mark, namely two intersecting stripes, with the two intersecting stripes placed on the sports shoes marketed by the EUTM proprietor; and (iii) infringement of Article 58(1) EUTMR, inasmuch as the contested decision was based on models of shoes whose marketing had not been proved. **On the three pleas in law.** (i) It may be inferred directly from the graphic representation of the mark at issue, and with sufficient precision, that the protection sought covered only a cross consisting of two black intersecting lines, represented in solid lines, as well as its position on the side of a sports shoe. The dotted lines, forming the outline of the sports shoe and its laces, are used, as is customary in similar situations, to permit a clearer delimitation of the mark (para. 40) (ii) It is clear from the evidence that the cross used on the various shoes is clearly discernible independently from the possible presence of the other details, which do not counteract its distinctiveness (para. 69). Evidence concerning sales of sport shoes in the MARCELO, MUNDIAL REVOLUTION, and GALES models (which are similar, even if the proportions and the colour used for the cross may vary) demonstrate use of the mark related to a sufficiently large and diverse territory in the EU. Moreover, the invoices relating to those models cover several years of the relevant period and they show actual, constant and uninterrupted use (paras 58-60). The figures from the invoices, in conjunction with the relevant catalogues, demonstrate marketing of numerous sports shoes with crosses on the side, which are identical or similar to the contested mark (para. 62). The distinctiveness of the contested mark has already been confirmed, and, in any event, the actual use of the registered mark can be proved even if its distinctive character proves to be rather weak (paras 74-75). (iii) The catalogues submitted as evidence regarding the REAGEE, TECNO and AVANT models, although they are not decisive evidence, may be assessed as an additional indication of the genuine use of a mark, insofar as this is a public and outward use of the mark or, at the very least, preparation for such use (para. 71).

♦[T-230/17](#); **RSTUDIO / ER STUDIO**; *Rstudio, Inc. v EUIPO*; Judgment of 7 March 2018; EU:T:2018:120; Language of the case: EN. The applicant sought to register the international registration No 999 644 designating the EU for the word mark **RSTUDIO** for the goods in Class 9 (*computer software for statistical computing using the R computing language; computer software for development of software applications for statistical computing using the R computing language*). An opposition based on the earlier word mark **ER/STUDIO** was filed pursuant to Article 8(1)(b) EUTMR designating goods in Class 9 (*database software and programmes; data modelling software and programmes; entity*





*relationship modelling software for SQL databases*). The applicant requested that the opponent submit proof of genuine use of the earlier mark. The Opposition Division (OD) upheld the opposition and the applicant filed a notice of appeal against it. The Board of Appeal (BoA) dismissed the appeal as it assessed the evidence of genuine use of the mark submitted by Embarcadero Technologies and found that such use had been proved for the relevant period; it found that the relevant public consisted of professionals, that the goods at issue were similar and that the degree of visual, phonetic and conceptual similarity between the signs was considerably high. It concluded that there was a likelihood of confusion (LOC). The applicant filed an action before the General Court (GC), relying on two pleas in law: (i) infringement of Article 47(2) and (3) EUTMR and (ii) infringement of Article 8(1)(b) EUTMR. **Proof of genuine use.** Since it is impossible for the proprietor of a trade mark to prove that the mark has been used for all conceivable variations of the goods belonging to the category of goods in question, the BoA was entitled to conclude that proof of genuine use of the earlier mark in connection with data modelling software and programmes and entity relationship modelling software for SQL databases necessarily afforded proof of genuine use in connection with the broader category of database software and programmes (para. 29).

♦[T-25/17](#); **PROTICURD / PROTIPLUS et al.**; *Bernhard Rintisch v EUIPO*; Judgment of 19 April 2018; EU:T:2018:195; Language of the case: EN

IR designating the EU	Earlier trade marks
<p><b>PROTICURD</b></p>	<p><b>PROTI</b> <b>PROTIPLUS</b></p> 

The international registration designating the European Union of the word mark **PROTICURD** was notified to the Office for registration for goods in Classes 5 and 29. An opposition based on the earlier German word marks **PROTI** and **PROTIPLUS** (Classes 29 and 32), as well as the German figurative mark above, was filed pursuant to Article 8(1)(b) EUTMR. The Opposition Division (OD) upheld the opposition and the IR holder appealed. The Board of Appeal (BoA) partially upheld the appeal and rejected the opposition for all the contested mark's goods in Class 5 (*pharmaceutical preparations; dietetic substances for medical purposes, dietetic preparations, dietary supplements, parapharmaceutical products, all for medical purposes*), and some of the goods in Class 29, namely milk powders and *milk beverages, with milk predominating*. The opponent filed an action before the General Court (GC) relying, inter alia, on the infringement of Article 8(1)(b) EUTMR. The GC upheld the plea in law based on the infringement of the duty to state reasons and annulled the BoA's decision. The case was referred to the BoA for a new ruling which annulled the OD's decision. The opponent filed an action before the GC relying on three pleas in law: (i) infringement of Article 94 EUTMR, (ii) infringement of Article 47(2) EUTMR, and (iii) infringement of Article 8(1)(b) EUTMR. **On the issue of genuine use.** The BoA did not err in finding that genuine use of the earlier mark PROTI had been proved solely for *preparations, particularly proteins, also supplemented with vitamins and or mineral salts, as well as carbohydrates, each particularly in powder form, for beverage preparation in Class 32* (para. 68).

**T-248/16; CHATKA (fig.) / CHATKA (fig.);** *Walfood SA v EUIPO*; Judgment of 25 April 2018; EU:T:2018:222; Language of the case: FR

EUTM application	Earlier trade mark
	

The predecessor in title of the EUTM proprietor registered the figurative mark above as an EUTM for *fish; fresh and frozen crustaceans; preserved crustaceans, including fresh crab, frozen and preserved* in Class 29. An application for invalidity was filed pursuant to Article 59(1)(a) EUTMR in conjunction with Article 8(1)(a) and (b) EUTMR and Article 8(5) EUTMR based on an international registration (IR) designating Spain for *canned crab* in Class 29. It is important to note that, although the IR was filed by Caviar Petrossian in 1990 for a number of countries including Spain, Sadco France became the holder of the IR in 1992 and allegedly signed a memorandum of understanding on 6 July 2004 with Arimpex Promoqualita presenting the latter as the distributor of the goods in Spain covered by the earlier mark since 1996. The Cancellation Division (CD) upheld the application for invalidity. The Board of Appeal (BoA) dismissed the EUTM proprietor’s appeal. It found that, first, the use of the earlier mark by Arimpex Promoqualita had been made with the consent of the then proprietor of the mark, Sadco France; secondly, that the evidence of use submitted sufficiently demonstrated the duration, extent and nature of use of the earlier mark; and third, that there was a risk of confusion between the conflicting signs. The EUTM proprietor appealed to the General Court (GC), relying on a single plea in law: infringement of Article 64 EUTMR, according to which, the invalidity applicant should have proven genuine use of the earlier IR for the five-year period preceding the filing of the application for invalidity (‘the first relevant period’) from 6 May 2000 to 5 May 2005, and for the five-year period preceding the date of publication of the application for registration of the contested mark (‘the second relevant period’), that is, from 6 December 1994 to 5 December 1999.

**Use of the earlier mark with the consent of the proprietor.** According to case-law, where the proprietor of a mark alleges acts of use of that mark by a third party as genuine use, it implicitly claims that this use was made with its consent. However, this is not applicable in the case at issue as the invalidity applicant was not the proprietor of the earlier IR during the second relevant period. Consequently, it could not authorise the use of the earlier mark during that period. Only Sadco France, the IR holder at that time, could have authorised use of the IR in Spain by Arimpex Promoqualita (paras 35-37). It can, however, be concluded that there was consent from Sadco France to the use of the IR made by Arimpex Promoqualita in Spain because a memorandum of understanding, inter alia, was signed by these two parties on 6 July 2004 stating that Sadco France ‘has commercial relations with the Spanish company Arimpex Promoqualita [...] which is a distributor of Russian royal crab in Spain under the brand name [Chatka] since 1996’ (para. 42). This memorandum — the authenticity of which is not disputed by the EUTM proprietor — was signed one year before the invalidity application and about ten years before the invalidity applicant was invited to produce proof of use, in June 2014. Therefore, the signing of the memorandum of understanding could not have been motivated by the need to produce proof of use before the Office (paras 48, 53). The memorandum is in fact a concrete piece of evidence which clearly establishes the consent of Sadco France to the use of the earlier mark by Arimpex Promoqualita (para. 57) and thus, the evidence of use of the IR in Spain emanating from Arimpex Promoqualita was taken into account by the Office (para. 63).



**Assessment of the evidence of use produced.** Since the EUTM proprietor has not disputed the BoA conclusion that genuine use of the IR for the first relevant period had been established, the GC confines its assessment to the second relevant period (para. 78). Furthermore, since the EUTM proprietor does not question the nature of the use of the earlier mark nor the fact that it was used in Spain, only the time and extent of the use are to be assessed, not the place and the nature of the use (para. 85). The invoices produced by the invalidity applicant show that the earlier mark was used between 9 June 1997 and 20 September 1999, namely for over two years, and this could properly be considered sufficient time, since according to settled case-law, Article 64 EUTMR does not imply that proof of genuine use of the earlier mark must be provided separately for each of the years of the five-year periods considered (paras 86-87). On extent of use, the 22 invoices issued by Arimpex Promoqualita to Spanish customers, dated from 1997 to 1999, show that 5 000 cans of crab were sold over a two-year period. This satisfactorily proves the extent of use considering, firstly, that canned Russian king crab cannot be regarded as an everyday consumer product; it is a gourmet product with a retail price of in between 25 and 35 EUR for less than 200 grams. Secondly, the sale of 5 000 cans on the Spanish market cannot be considered mere token use (paras 79, 91, 92, 104). The BoA was therefore entitled to find that there was genuine use of the earlier IR during the second relevant period and, accordingly, the appeal before the GC as a whole had to be rejected (para. 107).

**T-312/16; CHATKA / CHATKA (fig.);** *Walfood SA v EUIPO*; Judgment of 25 April 2018; EU:T:2018:221; Language of the case: EN

IR designating the EU	Earlier trade mark
CHATKA	

The applicant obtained an international registration (IR) designating the EU for the word mark **CHATKA** for goods and services in Classes 29, 33 and 43. The IR was published in the Community Trade Marks Bulletin on 29 May 2006. An opposition based on the IR designating Spain of the figurative mark above, for *preserved crab* in Class 29, was filed by the predecessor in title of the opponent pursuant to Article 47 in connection with Article 8(1)(b) EUTMR. It is important to note that, although the opposing IR had been filed by Caviar Petrossian in 1990 for a number of countries including Spain, Sadco France became the holder of that IR in 1992. In 2004, Sadco France transferred it to Arimpex Promoqualita only insofar as it designated Spain. In 2009, Arimpex Promoqualita transferred it, in turn, to the opponent, Romanov Holding SA. On 6 July 2004, the then holder of the opposing IR, Sadco France, allegedly signed an agreement with Arimpex Promoqualita presenting the latter as the distributor in Spain of the goods covered by the earlier mark since 1996. The Opposition Division (OD) upheld the opposition in relation to the goods in Class 29 and rejected it for the remainder. The Board of Appeal (BoA) dismissed the applicant's appeal finding that the opposition was well founded for the goods in Class 29. It found that use of the earlier mark by Arimpex Promoqualita had been made with the consent of the then proprietor of the mark, Sadco France; that the agreement of 6 July 2004 was reliable; that use of the earlier IR had been sufficiently proved; and that there was likelihood of confusion between the signs at issue. The applicant appealed to the General Court (GC), relying on one single plea in law: infringement of Article 47(2) and (3) EUTMR. **Period during which genuine use had to be examined.** It is clear from the wording of Article 47(2) EUTMR that the relevant period is to be calculated by reference to





the date of publication of the trade mark application (para. 26). As regards international registrations, the Office, after receiving notification of an international registration designating the European Union, undertakes the first publication of that registration in accordance with Article 190 EUTMR (para. 27). Consequently, it must be held that, the date of the first publication of an international registration designating the European Union is equivalent to the date of publication of the EU trade mark application to which Article 47(2) EUTMR refers. That finding is confirmed by Article 43 EUTMR and Article 195(4) EUTMR, which outline how the publication of an EU trade mark application, and the first publication of an international registration designating the EU, serve to inform the proprietors of earlier marks of the filing of the EU trade mark application or application for an international registration designating the European Union. They thus fulfil the same function, namely that of enabling the proprietor of an earlier mark to file an opposition or to comment on those applications (para. 29). The relevant period should therefore have run from 29 May 2001 to 28 May 2006 (and not from 30 November 2001 to 29 November 2006 as the BoA held) (para. 39). But the error of the BoA, in this respect, can only result in the annulment of the contested decision if it has an effect on the outcome of the present case (para. 40). **Use of the earlier mark with the consent of the proprietor.** When the BoA found that the opponent had consented to the use of the earlier mark by the applicant, it incorrectly applied the case-law whereby, when the proprietor of a trade mark maintains that use of the mark by a third party constitutes genuine use, he or she is claiming, by implication, that that use was made with his or her consent (para. 60). It can, however, be concluded that the owner of the mark at the time, Sadco France, did consent to the use of the opposing IR made by Arimpex Promoqualita in Spain because an agreement, inter alia, signed by these two parties on 6 July 2004 states that Sadco France ‘has commercial relations with the Spanish company Arimpex Promoqualita [...] which is a distributor of Russian royal crab in Spain under the brand name [Chatka] since 1996’ (para. 63). This agreement — the authenticity of which is not disputed by the applicant — was signed more than two years before the opposition proceedings were brought and around eight years before the applicant requested proof of use be provided. Therefore, the signing of the agreement could not have been motivated by the need to produce proof of use before the Office (para. 69). The agreement is in fact a concrete piece of evidence which clearly establishes the consent of Sadco France to the use of the earlier mark by Arimpex Promoqualita (para. 78), and thus, the proof of use of the IR in Spain emanating from Arimpex Promoqualita was taken into account by the Office (paras 86-87). **Assessment of the proof of use produced.** The error of the BoA in finding that the relevant period ran from 29 November 2001 to 28 November 2006, when in fact that period ran from 29 May 2001 to 28 May 2006, means that certain documents included in the proof of use provided by the opponent must be excluded (para. 109). However, their exclusion has no bearing on the outcome of the case (paras 110-111), as the rest of the documents sufficiently prove, as a whole, the time, place, nature and extent of use of the opposing mark. In particular, regarding the extent of use, evidence of a sales volume of around 3 700 cans over a five-year period, plus an order volume of around 6 000 units over two years was provided. Although relatively low, this cannot be considered to be token in nature (para. 124) since preserved Russian king crab cannot be regarded as an everyday consumer product; it is a gourmet product which has a retail price that can reach between EUR 25 and 30 for 185 grams (para. 122). The Board of Appeal was right in finding that the use of the earlier mark during the relevant period was genuine. Furthermore, the BoA’s error in determining the relevant period has no bearing on the outcome of the case and cannot lead to the annulment of the contested decision. Consequently, the single plea in law must be rejected and the action must be dismissed in its entirety (para. 152).

♦[T-429/17](#); **LABORATOIRES MAJORELLE / MAJORELLE et al.**; *Laboratoire Majorelle v*



*EUIPO*; Judgment of 3 May 2018; EU:T:2018:250; Language of the case: FR. The applicant sought to register the word mark **LABORATOIRES MAJORELLE** for the goods in Classes 3, 5 and 10. An opposition based on the earlier mark has been filed for the goods and services in Classes 3, 4, 5, 14, 16, 20, 21, 24, 25, 26, 28, 30, 41, 43 and 44 pursuant to Article 8(1)(b) EUTMR. The earlier mark **MAJORELLE**, which was being challenged in different opposition proceedings, was divided, and the part which covers goods in Classes 3, 5 and 10 was registered. The opposition was upheld for most of the goods, and the appeal dismissed by the Board of Appeal (BoA) as it found that there was a likelihood of confusion (LOC). The applicant appealed to the General Court (GC), relying on three pleas in law: (i) abuse in dividing the earlier right, (ii) absence of an examination of the genuine use of the divisional mark, and (iii) infringement of Article 8(1)(b) EUTMR. **On the first plea**, the applicant claimed that the opponent had abused their right to request a division of the earlier EUTM: by delaying this division, the opponent had purposefully slowed down the registration of the earlier mark, thus delaying the point in time when it becomes subject to proof of use. The GC considered the fact that the earlier EUTM was under opposition proceedings for some goods, therefore, the fact that its holder waited 3 years before applying for division does not amount to an ‘abuse of right’. Division can be applied for **at any time** before registration, without any obligation to file such a request without delay after an opposition is filed against some of the goods and services (para. 35). This may result in delaying the registration and thus the point in time when the divisional EUTM becomes subject to the genuine use requirement, but this is a reasonable counterpart for the limited rights granted by an EUTM application until registration is obtained (para. 36). The GC considered that the Office had no competence to assess the seriousness of the use of the earlier mark, irrespective of whether the opponent had submitted evidence of use on its own initiative (paras 42-44).

♦[T-882/16](#); **DOLFINA**; *Sipral World, SL v EUIPO*; Judgment of 7 June 2018; EU:T:2018:336; Language of the case: EN. The word mark **DOLFINA** was registered as an EUTM for goods in Classes 3, 18 and 25. A revocation application was filed pursuant to Article 58 EUTMR, submitting that the mark had not been genuinely used within a continuous period of five years. The Cancellation Division (CD) partly upheld the revocation application, namely for all the goods covered with the exception of *T-shirts and caps* in Class 25. The Board of Appeal (BoA) upheld the revocation applicant’s appeal, finding that the evidence regarding the place and extent of use of the mark for T-shirts and caps was insufficient. The EUTM proprietor filed an action before the General Court (GC) relying on two pleas in law: (i) lack of an adequate statement of reasons by the BoA and (ii) wrong appraisal of the evidence of use. **Reasoning of decision.** A clerical error in the contested decision did not prevent the parties from properly identifying evidence which the reasoning at issue was based on (para. 28). The GC held that this error could not deprive either party of the opportunity to defend its rights (para. 28). **Place of use.** From the photographs, it could not be established whether the EUTM had been used in the EU (para. 50). **Extent of use.** The submitted evidence relating to the mass consumption of T-shirts and caps did not establish sufficient extent of use to prove genuine use (para. 76).



♦ [T-72/17](#); **Steirisches Kürbiskernöl (fig.)**; *Gabriele Schmid v EUIPO*; Judgment of 7 June 2018; EU:T:2018:335; Language of the case: DE

EUTM	Trade mark as used
	

The contested figurative mark above was registered as an individual EUTM for *pumpkin seed oil produced according to the specifications underlying Council Regulation (EC) No 1263/96* in Class 29. A revocation request was filed for non-use (Article 58(1)(a) EUTMR), which the Cancellation Division (CD) upheld. The EUTM proprietor appealed the ruling before the Board of Appeal (BoA), which overturned the CD's decision, considering the evidence submitted to establish use of the contested mark. The revocation applicant appealed to the General Court (GC), alleging infringement of Article 18(1) EUTMR, Article 58(1)(a) EUTMR and Article 62(1) EUTMR. The GC found that the use shown of the contested — individual — mark does not demonstrate use in accordance with the mark's essential function, which is to assure that all the goods bearing that trade mark were manufactured under the control of a single undertaking (para. 55). As used, the mark merely indicates the geographical origin and quality of the goods, and does not allow the consumer to distinguish the goods of an undertaking covered by that trade mark from the goods covered by that trade mark but from other undertakings (para. 56). Since a mark must be used in accordance with its essential function, such use is not proper to maintain the rights to the contested individual mark.

♦ [T-739/16](#); **COSIMO / COSIFLOR**; *Akant Monika i Zbigniew Harasym sp.j. v EUIPO*; Judgment of 26 June 2018; EU:T:2018:387; Language of the case: EN. The applicant sought to register the word mark **COSIMO** as an EUTM for goods in Classes 20, 22 and 24. An opposition was filed pursuant to Article 8(1)(b) EUTMR, based on the earlier EU word mark **COSIFLOR**, registered for goods in Classes 6, 19 and 24. The Opposition Division (OD) dismissed the opposition, finding no likelihood of confusion (LOC). The opponent successfully appealed to the Board of Appeals (BoA), which found there was LOC for, at least, Dutch- and German-speaking consumers. The applicant appealed to the General Court (GC) relying on two pleas in law: (i) infringement of Article 47(2) EUTMR and (ii) infringement of Article 8(1)(b) EUTMR. **No request for proof of use.** The applicant merely stated, in its observations before the OD, that the opponent had not provided any evidence of use of the earlier mark. That declaration was not worded as an explicit and



unambiguous request for proof of use, and is more of a simple observation on the probative value of the documents produced. There is, moreover, no other material in the file capable of constituting such a request. The BoA acted correctly in taking the view that the applicant had not made a request for proof of genuine use of the earlier mark.

♦ **T-41/17; LOTTE (fig.) / KOALA SCHÖLLER (fig.); Lotte Co. Ltd v EUIPO**; Judgment of 12 July 2018; EU:T:2018:438; Language of the case: DE. The applicant sought to register the figurative mark **LOTTE (fig.)** as an EUTM for *cakes stuffed with chocolate cream; chewing gum not for medical purposes; chocolate; confectionery products; pastry; biscuits; aperitif biscuits; edible ices; pastry and confectionery* in Class 30. An opposition based on the earlier German figurative mark **KOALA SCHÖLLER (fig.)**, registered for goods in Class 30, was filed pursuant to Article 46 EUTMR. At the request of the applicant, the opponent filed evidence to prove the use of the earlier mark. The Opposition Division (OD) upheld the opposition. The Board of Appeal (BoA) upheld the applicant's appeal. It found that the opponent had not proven genuine use of the earlier mark. The opponent appealed to the General Court (GC). The GC upheld the appeal. It found that, contrary to the BoA's conclusion, it was possible to establish a link between the reproduction of the products on the extracts from the catalogues marked '2003' and '2005', and the price lists and invoices relating to those years. The GC therefore considered that the opponent had provided concrete and objective evidence to prove the use of the products identified under references 2A and 5A. The applicant appealed to the Court of Justice of the EU (CJ) against the GC judgment. The CJ dismissed the appeal and the proceedings resumed before the BoA, which annulled the OD decision and upheld the opposition for all the goods of the EUTM, with the exception of *chewing gum not for medical use*. The BoA found, firstly, that as the GC had ruled that the evidence submitted by the opponent proved use of the earlier mark, the BoA was no longer empowered to modify this conclusion, however, in accordance with the GC judgment, the BoA should determine whether the other conditions for establishing genuine use had been fulfilled, namely those relating to the extent of use. Secondly, the BoA found that the quantity of sales of the goods was sufficient to confirm genuine use of the earlier mark in Germany, but only for *biscuits*, an autonomous subcategory of certain goods covered by the earlier mark; and thirdly, the BoA found that there was a likelihood of confusion with regard to the goods considered to be identical or similar. The applicant appealed to the GC. **On the proof of use.** The applicant submitted that, contrary to what is indicated in the BoA decision, the products 'Koala Schoko', referenced under number 1460, were not listed in the 2003 and 2005 catalogues upon which the GC had based its conclusion regarding use of the earlier mark, thus, the invoices produced by the opponent, considered alone (with no possible reference to the catalogues), could not demonstrate that the article 'Koala Schoko' had been marketed in the form of use of the mark that the GC had accepted, namely, displayed on the packaging, (reproduced under references 2A and 5A in Annex 3 of the letter of 3 June 2014) (para. 29). However, insofar as the applicant, in claiming an 'absence of use' of the earlier mark, calls into question the existence of any use, it must be borne in mind that, in the context of an appeal to the EU Courts against the decision of a BoA, this proof of use is required, in accordance with Article 72(6) EUTMR, in order to comply with the judgment of the EU Courts and draw upon the consequences of the operative part of, and the reasons for, such a judgment (paras 30-31). The BoA, noting that the invoices provided by the opponent attest to the use of the packaging presented in the 2003 and 2005 catalogues, merely drew a conclusion about the reasons for the judgment of the Court. According to those reasons, the Court found that there was a 'link' between the goods identified under references 2A and 5A set out in the 2003 and 2005 catalogues and the price lists and invoices submitted by the applicant for the product referenced under number 1460 (paras 31-33). Bearing this in mind, the fact that the BoA erroneously stated in the contested decision that article 1460



was mentioned in the 2003 and 2005 catalogues is irrelevant (para. 37). **On the extent of use.** The sale of just over 7 000 packages of biscuits, which are inexpensive goods of mass consumption addressed to the general public, cannot be considered genuine use of the mark (paras 56-57). This finding is further confirmed by the fact that the invoices for 2005 show a turnover of EUR 3 709 and EUR 862 for 2003, that is, less than 0.1 % of the global turnover of the licensee company Kuchenmeister (para. 58). The low volume of goods marketed under the earlier mark is not offset by a high degree of intensity or constancy within the timeframe of use of that mark. Although the BoA claims the existence of repeated use, it should be noted that the six invoices on file prove only six acts of use in five years spread over a period of approximately 10 months (January 2003 to March 2003 and January 2005 to July 2005) (para. 61). All in all, the use of the earlier mark, based on the evidence produced by the opponent, cannot be regarded as genuine use for the purpose of maintaining or creating a market share (para. 62) so, the decision of the BoA must therefore be set aside (para. 63).

♦[T-797/17](#); **STAR**; *Star Television Productions Ltd v EUIPO*; Judgment of 13 July 2018; EU:T:2018:44169; Language of the case: FR. The figurative sign ‘STAR’ was registered as an EUTM for goods and services in Classes 9, 38 and 42. An application for revocation was filed pursuant to Article 58 EUTMR on the grounds that the mark had not been genuinely used. The Cancellation Division (CD) upheld the application for revocation. The Board of Appeal (BoA) dismissed the EUTM proprietor’s appeal as it found, firstly, that the proof of use submitted corresponded to services in Class 41 and not to the goods and services for which the mark was registered and, secondly, the evidence concerning the extent of use of the mark was insufficient. The EUTM proprietor appealed to the General Court (GC) relying on one plea in law: (i) infringement of Article 58(1)(a) EUTMR. **Extent of use.** The evidence relating to the production of contents for broadcasting companies does not serve to prove use of the mark for telecommunications services in Class 38, because those services fall under Class 41, which is not at issue (paras 49-50). The evidence submitted, which the BoA did consider as a whole, does not contain quantified elements enabling the EUIPO to establish the importance or extent of the use of the mark for the goods and services for which the mark was registered (paras 29-31, 45, 61, 62, 66). **Statements in writing.** Since the statements in writing were submitted by someone bound by an employment relationship with the EUTM proprietor, namely the Director General, other items of evidence needed to be submitted and examined in order to corroborate the contents of the statements. These subsequent documents were not sufficient to illustrate the use of the mark in question. **Examination of evidence.** The evaluation of whether the use of the mark was duly proved does not need to include an individual examination of each piece of evidence since the assessment is made considering all the available evidence as a whole (para. 58).



**T-219/17; SHAPE OF A KANGAROO SEEN FROM DIFFERENT VIEWS (3D);**  
*M J Quinlan & Associates Pty Ltd v EUIPO*; Judgment of 27 September 2018;  
 EU:T:2018:610; Language of the case: DE

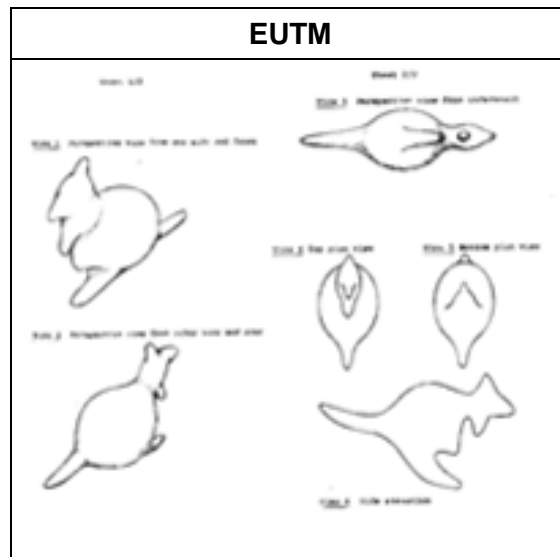

The EUTM proprietor obtained registration of the shape mark above as an EUTM for, inter alia, goods in Class 29. An application for revocation was filed pursuant to Article 58(1)(a) EUTMR alleging that the mark had not been genuinely used for a continuous period of 5 years, namely between 5 September 2009 and 4 September 2014. The Cancellation Division (CD) partially dismissed the revocation application as it found that the EUTM proprietor had consented to the use of the contested mark by the revocation applicant, that the parties were related by a licence agreement dated 19 January 1994 concerning the EUTM proprietor's national patents and designs for kangaroo-shaped snacks, that the revocation applicant was aware of the contested mark since it had objected to its registration, and that the evidence produced showed that the contested mark of the EUTM proprietor was used as a trade mark for kangaroo-shaped potato chips and potato snacks. The revocation applicant filed an appeal. The Board of Appeal (BoA) partially upheld the appeal and annulled the contested decision insofar as it had maintained the registration for *snacks, namely potato-based snacks, potato chips, foods (salted), namely potato-based snacks*. It found, first, that the CD had wrongly considered that the EUTM proprietor had granted to the revocation applicant the right to use the three-dimensional kangaroo shape as a trade mark for snacks, and, second, that it was not possible to establish from the documents submitted that the contested mark had been genuinely used. The EUTM proprietor appealed to the General Court (GC), relying on three pleas in law: (i) infringement of Article 58(1)(a) EUTMR, (ii) of Article 58(1)(a) EUTMR in conjunction with Article 18(2) EUTMR and (iii) of Article 58(1)(a) EUTMR in conjunction with Article 18(1)(b) EUTMR. **Proof of use of the trade mark.** The evidence submitted by the EUTM proprietor does not prove genuine use of the three-dimensional mark in the form of a kangaroo (para. 47). To start with, part of the evidence does not have to do with the question of the use of the contested mark (para. 35). Some of the items of evidence do not concern the relevant period (paras 36-38). Insofar as the images of the packaging of the products submitted as evidence of use are concerned, it must be considered that the packaging in question contains word elements, such as 'jumpy's', 'funny frisch', 'wolf' or 'wolf intersnacks', or the figurative element of a stylised silhouette of a kangaroo, and it is these elements that dominate the foreground of the packaging of the products, whereas the two-



dimensional representations of the contested mark appear as an ancillary figurative element, even marginal, in the background of the packaging. Therefore, the consumer is likely to perceive the goods as coming from the company identified by the verbal and figurative elements present on the abovementioned packaging, which, because of their size, colour and proportions, will draw their attention more than the two-dimensional representation of the contested mark (para. 39). Since the package is not transparent, the snacks inside were not examined. A market survey titled 'Reputation and distinctiveness of salty snacks that look like the form of a kangaroo', which was carried out in Germany in January 2015 by an independent company, shows that this shape for snacks was known by about 60 % of the people consulted, but only half of them perceived the snacks in the three-dimensional form of a kangaroo as coming from a specific company. In particular, the market survey concluded that less than one third of those surveyed associated snacks in the shape of three-dimensional kangaroos with the different brands used by the cancellation applicant (paras 42-45). **Use of the mark with the consent of its proprietor.** The question of whether the cancellation applicant used the mark or not with the consent of the proprietor is irrelevant, as it cannot alter the already reached conclusion that the submitted evidence was insufficient to prove genuine use (para. 51). **Proof of use of the contested mark for export purposes.** Even if it were true that the BoA had not examined the evidence of use of the contested mark for export purposes, the corresponding plea in law would be ineffective as the evidence of use of the mark for export is subject to the same objections already discussed in relation to the first plea (paras 55-56). The action of the proprietor must be dismissed and consequently its EUTM is revoked.

♦[T-24/17](#); **D-TACK / TACK et al.**; *LA Superquimica, SA v EUIPO*; Judgment of 10 October 2018; EU:T:2018:668; Language of the case: EN

EUTM application	Earlier trade marks
D-TACK	<p style="text-align: center;">TACK <i>used as</i> TACKCEYS</p> 

The predecessor of D-Tack GmbH sought to register the word mark **D-TACK** for the goods and services in Classes 1, 17 and 35. An opposition was filed based on six Spanish earlier rights (above), pursuant to Article 5 EUTMR and Article 8(1)(b) EUTMR. The Opposition Division (OD) rejected the opposition in its entirety because proof of the earlier marks had not been provided and the evidence of use of the earlier mark was insufficient. The opponent appealed against the OD's decision. The Board of Appeal (BoA) dismissed it as the evidence provided showed use that altered the distinctive character of the earlier mark



as registered. The opponent filed an action with the General Court (GC), relying on two pleas in law: (i) infringement of the rules on the substantiation of the registrations of the earlier marks and (ii) infringement of the rules on proof of use of the earlier word mark **TACK**. **On the alleged infringement of the rules on proof of use.** The relevant public is the Spanish public (not contested) (para. 51). For the goods at issue, the words ‘tack’ and ‘ceys’ have at least an average distinctive character (para. 52). The BoA’s conclusion that the use of the word ‘tackceys’ in the invoices, in the text of the brochures and catalogues alters the distinctive character of the earlier word mark **TACK** and cannot be regarded as an acceptable variation of the use, must be approved (para. 56). The BoA noted that the two elements ‘tack’ and ‘ceys’ are systematically juxtaposed and always appear conjoined, forming an indivisible unit. Even though the element ‘ceys’ is smaller and represented in a different colour and font type, that added element is still clearly visible and does not occupy a secondary or ancillary position in the overall impression produced by the combination ‘tackceys’ (para. 58). The BoA rightly found that the last letter, ‘k’, appears to frame the following part of the sign, namely, the band or arrow pointed towards the term ‘tack’ on which the element ‘ceys’ appears (para. 59). The finding that the distinctive character of the earlier word mark **TACK**, as registered, has been altered is supported by the addition of other terms like ‘crick’, ‘cristal’ or ‘bricocinta’ (para. 60). The earlier word mark **TACK** and the combination ‘tackceys’ cannot be regarded as broadly equivalent (para. 61). The BoA rightly found that the variations in use shown alter the distinctive character of the earlier word mark **TACK** as it is registered (para. 63). The BoA did not infringe point (a) of the second subparagraph of Article 18(1) EUTMR, read in conjunction with Article 47(2) and (3) EUTMR, given the alteration of the earlier word mark **TACK** in the evidence produced by the opponent (para. 64).

♦[T-171/17](#); **KIMIKA / KAMIK**; *M & K Srl v EUIPO*; Judgment of 16 October 2018; EU:T:2018:683; Language of the case: EN

EUTM application	Earlier mark ‘as registered’	Earlier mark ‘as used’
<b>KIMIKA</b>	<b>KAMIK</b>	<b>kamik</b> 

The applicant sought to register the word mark **KIMIKA** for goods in Classes 14, 18 and 25. An opposition based on the earlier EU word mark **KAMIK** registered for goods in Class 25 was filed pursuant to Article 8(1)(b) EUTMR. The applicant, pursuant to Article 47(2) and (3) EUTMR, submitted a request for the opponent/intervener to submit proof of genuine use. The intervener then provided various documents in order to show that the earlier trade mark had indeed been genuinely used. The Opposition Division (OD) upheld the opposition and the applicant filed an appeal against the OD’s decision. The Board of Appeal (BoA) dismissed the appeal as it found that there was a likelihood of confusion (LOC). The applicant filed an action with the General Court (GC), relying on two pleas in law: (i) infringement of Article 47(2) and (3) EUTMR read in conjunction with Article 18(1) and (2) EUTMR and (ii) infringement of Article 8(1)(b) EUTMR. **Use in a different form.** The invoices produced by the intervener do not feature the earlier mark in the form in which it was registered, but in a different form comprising (a) the stylisation of the letters of the word ‘kamik’ in italics and (b) the addition of a figurative element next to that word. These differences amount to only minor graphical variations, which are not such as to alter the distinctive character of the mark as originally registered (paras 36-41). **Use for the registered goods.** The evidence produced by the intervener during the opposition proceedings, considered as a whole, concerns not only *boots*, as argued by the applicant,





but also *sandals* and other items falling under the category of *footwear* in Class 25. Therefore, the goods protected by the earlier trade mark for which genuine use has been shown cover all the types of *footwear* in Class 25 (paras 51 and 52). As genuine use of the earlier mark has been proved for *footwear*, the first plea in law must be rejected (para. 53).

**T-109/17; VIPER / VIPER et al.; FCA US LLC v EUIPO**; Judgment of 18 October 2018; EU:T:2018:697; Language of the case: EN. The EUTM proprietor registered the word mark **VIPER** as an EUTM for goods in Classes 12, 28 and 37. An invalidity application was filed pursuant to Articles 59(1)(a) and 60(1)(a) EUTMR in conjunction with Article 8(1)(a) and (b) and Article 8(5) EUTMR, based, inter alia, on the earlier United Kingdom word mark **VIPER**, registered for *sports cars; all included in Class 12*. The Cancellation Division (CD) partially upheld the invalidity application for *motor vehicles and parts thereof* in Class 12. The EUTM proprietor filed an appeal, which the BoA dismissed. It found that genuine use of the earlier mark had been proved for *sports cars in kit form*, which were regarded as a subcategory of the *sports cars* covered by that mark. The EUTM proprietor appealed to the General Court (GC), relying on a single plea in law: infringement of Article 64(2) and (3) EUTMR. **Alleged incomplete nature of kits and decisiveness for proof of use.** The BoA correctly defined kit cars as cars that, in principle, must be assembled by the customers themselves. The latter are car enthusiasts who are prepared to devote considerable time and resources to assembling a vehicle themselves using the particular concept developed and sold by the kit car supplier. The purpose is thus to have a specific car, which, following assembly, may be deemed roadworthy. It is also apparent from articles published in specialist magazine *kitcar* that such cars may take several months or even years to build (para. 47). Therefore, kit cars have certain specificities and are, moreover, niche products (para. 48). The BoA correctly took account of the nature of the goods as well as the characteristics of the relevant market (para. 50). The BoA also referred to the comprehensive nature of the kits, but that does not mean it concluded that the goods sold by the invalidity applicant were kits containing all the components necessary to build a car (paras 52-53). It is apparent from the file that the kits proposed also include components from other manufacturers, such as the engine or suspension (para. 58). However, even the use of the earlier trade mark for partial kits only, sold for the building of specific sports cars in kit form, may be considered, taking account of the purpose of the goods, as falling within the scope of *sports cars in kit form*. Accordingly, the question whether all the components of the VIPER sports cars in kit form are manufactured or sold by the invalidity applicant is not decisive (para. 59). **On the alleged reliance on a dictionary definition of the term ‘kit-car’.** The BoA based its analysis on the evidence submitted that dated from the relevant period, and, in particular, on the articles published in specialist magazine *kitcar*, as well as on the frequent and regular insertion of advertisements concerning the earlier mark in that magazine. The BoA did not err in finding that the earlier mark had been used *for sports cars in kit form* (paras 60-61). **Proof and extent of use of the earlier mark.** The evidence produced by the invalidity applicant shows that kits for building VIPER sports cars were consistently sold or, at least, offered on the relevant niche market during the relevant period (para. 71). The invalidity applicant regularly promoted the VIPER sports car in specialist magazine *kitcar* during the relevant period. The initial evidence was sufficient to show that the VIPER sports car and, therefore, the earlier mark, were present at several kit car showrooms during the relevant period (para. 69). Moreover, the initial evidence is corroborated by additional evidence (invoices, press articles, certificates, search results, etc.) regarding use of kits for the construction of a VIPER sports car (para. 70). Admittedly, none of the evidence pertaining to the relevant period, taken individually, demonstrates the volume of goods sold under the earlier mark, and only a few invoices refer essentially to partial kits for the construction of the VIPER sports car. However, given the specificities of the relevant market, the evidence, taken as a whole, shows genuine use that cannot be considered



symbolic or for the sole purpose of preserving the rights conferred by the mark (para. 72).

♦[T-44/17](#); **CAMOMILLA / CAMOMILLA (fig.)**; *Camomilla Srl v EUIPO*; Judgment of 13 November 2018; EU:T:2018:775; Language of the case: IT. The EUTM proprietor registered the word mark **CAMOMILLA** as an EUTM for goods in, inter alia, Classes 18 and 25. An invalidity application was filed pursuant to Articles 59(1)(b) and 60(1)(a) EUTMR in conjunction with Article 8(1)(b) and Article 8(5) EUTMR, based on the earlier Italian figurative mark above, registered for Class 25 (*clothing and clothing accessories of all types*). The Cancellation Division (CD) dismissed the invalidity application, insofar as it found, inter alia, that the invalidity applicant had not adduced proof of use of the earlier mark and there was no likelihood of confusion (LOC). The invalidity applicant filed an appeal. The Board of Appeal (BoA) dismissed the appeal, finding, inter alia, that the use of the earlier mark was not sufficiently proven, and that certain documents were inadmissible as submitted for the first time before the BoA. The invalidity applicant filed an action before the General Court (GC), which the GC upheld, considering the belated evidence to be admissible as complementary. After remittal, the BoA re-examined the appeal and partially upheld it, insofar as it found that the earlier mark had previously been used in Italy for goods in Class 25 and that there was LOC for goods in Classes 18 and 25. The EUTM proprietor filed an action before the GC, relying on four pleas in law: (i) infringement of Article 94 EUTMR, (ii) infringement of Article 95(1) EUTMR, (iii) infringement of Article 60(1)(a) EUTMR in conjunction with Article 8(1)(b) EUTMR, and (iv) infringement of Article 64(3) EUTMR in conjunction with Article 64(2) EUTMR. **Place of use.** The list of sales points provided by the invalidity applicant and the declarations made by several clients prove that the trade mark has established a particular presence in southern Italy and has, moreover, been marketed — albeit to a much lesser extent — in other shops and franchise points throughout the country (para. 61). **Nature of use.** Regarding the use of the trade mark to designate the relevant goods, a pair of shoes bearing the label ‘CAMOMILLA’ appears in the invalidity applicant’s catalogue for the spring/summer 2004 collection. In addition, a blouse sporting the ‘CAMOMILLA’ label appears in the March 2006 and September 2006 editions of Camomilla Magazine (para. 62). Therefore, it is proved that the trade mark was used to designate goods such as clothing, footwear and clothing accessories during the relevant period (para. 63). **Extent of use.** The purpose of proof of use is not to assess commercial success or to review the economic strategy of an undertaking, nor is it intended to restrict trade mark protection only to large-scale commercial use of the marks (para. 64). It is clear from the summary tables of sales figures that the invalidity applicant recorded annual sales of over EUR 10 million from 2004 to 2009 (para. 65). The information relating to 2004 is corroborated by the newspaper article published in Italia Oggi, which describes ‘CAMOMILLA’ as a ‘Neapolitan’ trade mark that recorded sales figures of EUR 20 million in 2004 (para. 68).

♦[C-340/17 P](#); **ALCOLOCK**; *Alcohol Countermeasure Systems (International) Inc. v EUIPO*; Judgment of 29 November 2018; EU:C:2018:965; Language of the case: EN. The EUTM proprietor registered the word mark **ALCOLOCK** as an EUTM for goods and services in Classes 9, 37 and 42. An invalidity application was filed pursuant to Article 60(1)(a) EUTMR in conjunction with, inter alia, Article 8(1)(a) and (b) EUTMR and based on the earlier United Kingdom word mark **ALCOLOCK** for goods in Class 9. The Cancellation Division (CD) upheld the invalidity application. It found that the earlier mark had been genuinely used, that the goods and services in question were identical or similar, and that the signs at issue were identical. The invalidity applicant filed an appeal. The Board of Appeal (BoA) dismissed the appeal. It found that the invalidity applicant had established to the requisite legal standard that the earlier mark had been genuinely used in the United Kingdom, that some of the goods in question were identical, as were the signs at issue, and that there was



a likelihood of confusion (LOC) between those signs within the meaning of Article 8(1) EUTMR. The proprietor appealed to the General Court (GC), contesting, in essence, the BoA's assessment of the genuine use of the earlier mark. The GC dismissed the appeal. It found that proof of genuine use of the earlier mark could be submitted by means of evidence relating to the use of another word mark consisting of the same sign, **ALCOLOCK**. The proprietor appealed to the Court of Justice of the European Union (CJ). **Proof of genuine use of earlier marks.** Use of a sign identical to that constituting the earlier mark and itself registered as a trade mark under a different number from the earlier mark, constitutes use of that mark for the purposes of applying the first subparagraph of Article 18(1) EUTMR (para. 58). **Impact of the 23 June 2016 referendum on withdrawal of the United Kingdom from the EU.** The GC may not, according to the case-law of the CJ, annul or alter a decision of the BoA on grounds that come into existence after its adoption (para. 116). The GC was thus not required to stay the proceedings pending before it following the United Kingdom's referendum on withdrawal from the EU on the ground, moreover purely hypothetical at that stage, that said withdrawal would retroactively affect the outcome of invalidity proceedings based on an earlier trade mark of that Member State (para. 117). Furthermore, the mere communication by a Member State of its intention to leave the EU in accordance with Article 50 of the Treaty on European Union (TEU) does not have the effect of suspending the application of EU law in that Member State. Consequently, EU law continues in full force and effect in that Member State until the time of its actual withdrawal from the European Union (para. 118).

---

## V. OTHER CANCELLATION GROUNDS

### A. Article 58(1)(a) EUTMR — Revocation due to non-use

♦[T-68/16](#); **DEVICE OF A CROSS ON A SPORT SHOE SIDE (fig.)**; *Deichmann SE v EUIPO*; Judgment of 17 January 2018; EU:T:2018:7; Language of the case: EN. The figurative mark 'DEVICE OF A CROSS ON A SPORT SHOE SIDE (fig.)' was registered as an EUTM for goods in Class 25 (*sports footwear*). An application for revocation was filed pursuant to Article 58(1)(a) EUTMR. The Cancellation Division (CD) upheld the application for revocation insofar as it found that the evidence provided demonstrated use of the mark in a form that altered the distinctive character of the mark as registered. Upon appeal, the Board of Appeal (BoA) annulled the CD's decision and rejected the application for revocation. It held that the evidence adduced showed genuine use of the mark and that the differences between the mark as used and the contested mark were negligible. The revocation applicant filed an action before the General Court (GC) relying on three pleas in law: (i) infringement of Article 58(1)(a) EUTMR, inasmuch as the BoA wrongly assessed the subject matter of the contested mark, by holding that it was irrelevant whether the mark was a figurative mark or a position mark; (ii) infringement of Articles 58(1) and 18(1) EUTMR, inasmuch as, in order to determine whether the mark was used in its registered form or in a form that did not alter its distinctive character, the BoA merely compared a part of the mark, namely two intersecting stripes, with the two intersecting stripes placed on the sports shoes marketed by the EUTM proprietor; and (iii) infringement of Article 58(1) EUTMR, inasmuch as the contested decision was based on models of shoes whose marketing had not been proved. **On the three pleas in law.** (i) It may be inferred directly from the graphic representation of the mark at issue, and with sufficient precision, that the protection sought covered only a cross consisting of two black intersecting lines, represented in solid lines, as well as its position on the side of a sports shoe. The dotted lines, forming the outline of the sports shoe and its laces, are used, as is customary in similar situations, to permit a clearer delimitation of the mark (para. 40) (ii) It is clear from the evidence that the cross used on



the various shoes is clearly discernible independently from the possible presence of the other details, which do not counteract its distinctiveness (para. 69). Evidence concerning sales of sport shoes in the MARCELO, MUNDIAL REVOLUTION, and GALES models (which are similar, even if the proportions and the colour used for the cross may vary) demonstrate use of the mark related to a sufficiently large and diverse territory in the EU. Moreover, the invoices relating to those models cover several years of the relevant period and they show actual, constant and uninterrupted use (paras 58-60). The figures from the invoices, in conjunction with the relevant catalogues, demonstrate marketing of numerous sports shoes with crosses on the side, which are identical or similar to the contested mark (para. 62). The distinctiveness of the contested mark has already been confirmed, and, in any event, the actual use of the registered mark can be proved even if its distinctive character proves to be rather weak (paras 74-75). (iii) The catalogues submitted as evidence regarding the REAGEE, TECNO and AVANT models, although they are not decisive evidence, may be assessed as an additional indication of the genuine use of a mark, insofar as this is a public and outward use of the mark or, at the very least, preparation for such use (para. 71).

**C-148/17; Peek & Cloppenburg; Peek & Cloppenburg KG, Hamburg v Peek & Cloppenburg KG, Düsseldorf; Preliminary ruling of 19 April 2018; EU:C:2018:271; Language of the case: DE.** The request for a preliminary ruling has been made in proceedings between Peek & Cloppenburg KG, Hamburg and Peek & Cloppenburg KG, Düsseldorf concerning a declaration a posteriori that the national marks owned by P & C Hamburg, which it had previously surrendered, are void. P & C Düsseldorf is the proprietor of the German word mark **PuC** and figurative mark 'PuC', and P & C Hamburg is the proprietor of the EU word mark **PUC**. P & C Düsseldorf brought an action for cancellation, due to revocation, of the German word marks **PUC**. Since P & C Hamburg voluntarily applied for the cancellation of those marks before the German Patent and Trade Mark Office, both parties declared that they were putting an end to the dispute, and the marks in question were cancelled. Later on, P & C Düsseldorf brought an action before the Landgericht Hamburg (Regional Court, Hamburg, Germany) for an order that P & C Hamburg may no longer claim the seniority of the German word marks **PUC**, arguing, primarily, that on the date on which they were cancelled after the surrender on behalf of the company, they could also have been cancelled due to revocation and, in the alternative, due to earlier rights of P & C Düsseldorf. The Regional Court, Hamburg upheld the action, and the appeal before the Oberlandesgericht Hamburg (Higher Regional Court, Hamburg, Germany) brought by P & C Hamburg, was dismissed. P & C Hamburg then lodged an appeal on a point of law against that decision before the Bundesgerichtshof (Federal Court of Justice, Germany). The referring court is uncertain about the effect of claiming for an EU trade mark the seniority of an earlier national mark and, therefore, decided to refer to the court for a preliminary ruling. **Questions.** (1) Is the fact that the invalidity or revocation of a national trade mark that forms the basis of a claim for the seniority of an EU trade mark and that has been surrendered or allowed to lapse may be established a posteriori only where the conditions of invalidity or revocation are present, not only at the time when the trade mark was surrendered or allowed to lapse but also at the time of the judicial decision establishing its invalidity or revocation, compatible with Article 14 of Directive (EC) 2008/95? (2) If the first question is to be answered in the affirmative: does claiming seniority under Article 39(3) EUTMR have the effect that the right under the national trade mark lapses and can no longer be used in such a way as to maintain rights attached to it, or is the national trade mark preserved by virtue of EU law, even though it no longer exists in the register of the Member State concerned, with the result that it can and must continue to be used in such a way as to maintain the rights attached to it? **Answer.** Article 14 of Directive (EC) 2008/95, read in conjunction with Article 39(3) EUTMR, must be interpreted as



precluding an interpretation of national legislation according to which the invalidity or revocation of an earlier national mark, the seniority of which is claimed for an EU mark, may be established a posteriori only if the conditions for that invalidity or that revocation were met, not only on the date on which the earlier national mark was surrendered or the date on which it lapsed, but also on the date on which the judicial decision making that finding is taken (para. 32). The use of the mark is taken into consideration only on the date of the filing of the application for revocation. Taking this into consideration, in proceedings seeking to establish a posteriori the revocation of a mark, the use made after the date on which the proprietor himself declared its surrender of that mark or allowed it to lapse would not be consistent with Article 12(1) of Directive (EC) 2008/95 (para. 29). Any use of the mark after its cancellation must be regarded as use of the EU mark and not of the cancelled earlier national mark (para. 30).

♦[T-34/17](#); **SKYLEADER (fig.)**; *Skyleader a.s v EUIPO*; Judgment of 4 May 2018; EU:T:2018:256; Language of the case: EN. The applicant registered the figurative mark ‘SKYLEADER’ as an EUTM for goods in Classes 12 and 14. An application for revocation was filed pursuant to Article 58 EUTMR. The Cancellation Division (CD) set the applicant a time limit of 3 months to submit proof of genuine use of the mark. Within this time limit, the applicant submitted a two-page fax in which it listed, via annexes, proof of genuine use of the mark that was to be sent to the Office by courier. The listed documents were sent by mail within the time limit but the Office received them after the time limit. The CD informed the parties that the proof of use would not be taken into account since it was received outside the time limit set, and it upheld the application for revocation. The applicant appealed and the Board of Appeal (BoA) dismissed the appeal, as it found that the original documents containing the proof of use were received outside the time limit set. Moreover, the applicant did not take up the opportunity it was given of requesting an extension of the time limit or the continuation of proceedings, or of filing a request for *restitutio in integrum*. The applicant filed an action before the General Court (GC) relying on two pleas in law: (i) infringement of Article 19(1) EUTMDR in conjunction with Article 95(2) EUTMR, and (ii) infringement of the principle of sound administration. **Infringement of Article 19(1) EUTMDR in conjunction with Article 95(2) EUTMR.** In revocation proceedings, where no proof of use is submitted within the time limit, the mark should be revoked of its own motion, as it is for the proprietor to establish genuine use of the mark. Therefore, the Office must revoke a mark where no proof of use has been provided within the time limit set (paras 32 and 34). Only the letter sent by fax was provided to the CD within the time limit (para. 35). It is apparent from that letter that proof of use, listed as annexes, was to be sent to the Office by post (para. 39).

♦[T-882/16](#); **DOLFINA**; *Sipral World, SL v EUIPO*; Judgment of 7 June 2018; EU:T:2018:336; Language of the case: EN. The word mark **DOLFINA** was registered as an EUTM for goods in Classes 3, 18 and 25. A revocation application was filed pursuant to Article 58 EUTMR, submitting that the mark had not been genuinely used within a continuous period of five years. The Cancellation Division (CD) partly upheld the revocation application, namely for all the goods covered with the exception of *T-shirts and caps* in Class 25. The Board of Appeal (BoA) upheld the revocation applicant’s appeal, finding that the evidence regarding the place and extent of use of the mark for T-shirts and caps was insufficient. The EUTM proprietor filed an action before the General Court (GC) relying on two pleas in law: (i) lack of an adequate statement of reasons by the BoA and (ii) wrong appraisal of the evidence of use. **Reasoning of decision.** A clerical error in the contested decision did not prevent the parties from properly identifying evidence which the reasoning at issue was based on (para. 28). The GC held that this error could not deprive either party of the opportunity to defend its rights (para. 28). **Place of use.** From the photographs, it



could not be established whether the EUTM had been used in the EU (para. 50). **Extent of use.** The submitted evidence relating to the mass consumption of T-shirts and caps did not establish sufficient extent of use to prove genuine use (para. 76).

♦ [T-72/17](#); **Steirisches Kürbiskernöl (fig.)**; *Gabriele Schmid v EUIPO*; Judgment of 7 June 2018; EU:T:2018:335; Language of the case: DE

EUTM	Trade mark as used
	

The contested figurative mark above was registered as an individual EUTM for *pumpkin seed oil produced according to the specifications underlying Council Regulation (EC) No 1263/96* in Class 29. A revocation request was filed for non-use (Article 58(1)(a) EUTMR), which the Cancellation Division (CD) upheld. The EUTM proprietor appealed the ruling before the Board of Appeal (BoA), which overturned the CD's decision, considering the evidence submitted to establish use of the contested mark. The revocation applicant appealed to the General Court (GC), alleging infringement of Article 18(1) EUTMR, Article 58(1)(a) EUTMR and Article 62(1) EUTMR. The GC found that the use shown of the contested — individual — mark does not demonstrate use in accordance with the mark's essential function, which is to assure that all the goods bearing that trade mark were manufactured under the control of a single undertaking (para. 55). As used, the mark merely indicates the geographical origin and quality of the goods, and does not allow the consumer to distinguish the goods of an undertaking covered by that trade mark from the goods covered by that trade mark but from other undertakings (para. 56). Since a mark must be used in accordance with its essential function, such use is not proper to maintain the rights to the contested individual mark.



♦[T-797/17](#); **STAR**; *Star Television Productions Ltd v EUIPO*; Judgment of 13 July 2018; EU:T:2018:44169; Language of the case: FR

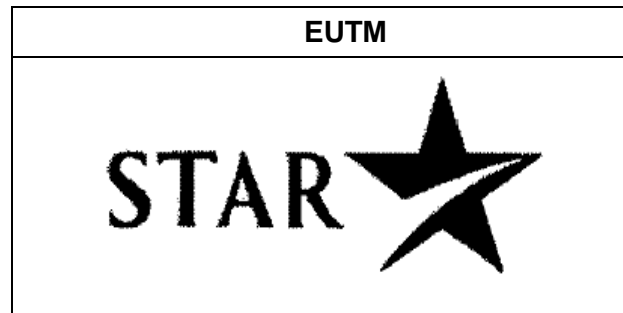

The figurative sign above was registered as an EUTM for goods and services in Classes 9, 38 and 42. An application for revocation was filed pursuant to Article 58 EUTMR on the grounds that the mark had not been genuinely used. The Cancellation Division (CD) upheld the application for revocation. The Board of Appeal (BoA) dismissed the EUTM proprietor’s appeal as it found, firstly, that the proof of use submitted corresponded to services in Class 41 and not to the goods and services for which the mark was registered and, secondly, the evidence concerning the extent of use of the mark was insufficient. The EUTM proprietor appealed to the General Court (GC) relying on one plea in law: (i) infringement of Article 58(1)(a) EUTMR. **Extent of use.** The evidence relating to the production of contents for broadcasting companies does not serve to prove use of the mark for telecommunications services in Class 38, because those services fall under Class 41, which is not at issue (paras 49-50). The evidence submitted, which the BoA did consider as a whole, does not contain quantified elements enabling the EUIPO to establish the importance or extent of the use of the mark for the goods and services for which the mark was registered (paras 29-31, 45, 61, 62, 66). **Statements in writing.** Since the statements in writing were submitted by someone bound by an employment relationship with the EUTM proprietor, namely the Director General, other items of evidence needed to be submitted and examined in order to corroborate the contents of the statements. These subsequent documents were not sufficient to illustrate the use of the mark in question. **Examination of evidence.** The evaluation of whether the use of the mark was duly proved does not need to include an individual examination of each piece of evidence since the assessment is made considering all the available evidence as a whole (para. 58).



**T-219/17; SHAPE OF A KANGAROO SEEN FROM DIFFERENT VIEWS (3D);**  
*M J Quinlan & Associates Pty Ltd v EUIPO*; Judgment of 27 September 2018;  
 EU:T:2018:610; Language of the case: DE

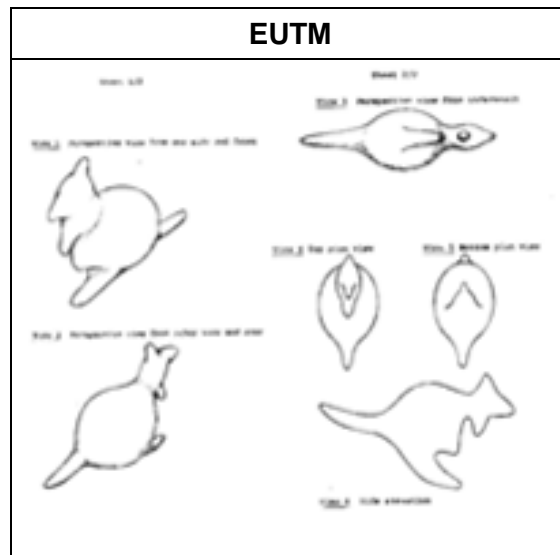

The EUTM proprietor obtained registration of the shape mark above as an EUTM for, inter alia, goods in Class 29. An application for revocation was filed pursuant to Article 58(1)(a) EUTMR alleging that the mark had not been genuinely used for a continuous period of 5 years, namely between 5 September 2009 and 4 September 2014. The Cancellation Division (CD) partially dismissed the revocation application as it found that the EUTM proprietor had consented to the use of the contested mark by the revocation applicant, that the parties were related by a licence agreement dated 19 January 1994 concerning the EUTM proprietor's national patents and designs for kangaroo-shaped snacks, that the revocation applicant was aware of the contested mark since it had objected to its registration, and that the evidence produced showed that the contested mark of the EUTM proprietor was used as a trade mark for kangaroo-shaped potato chips and potato snacks. The revocation applicant filed an appeal. The Board of Appeal (BoA) partially upheld the appeal and annulled the contested decision insofar as it had maintained the registration for *snacks, namely potato-based snacks, potato chips, foods (salted), namely potato-based snacks*. It found, first, that the CD had wrongly considered that the EUTM proprietor had granted to the revocation applicant the right to use the three-dimensional kangaroo shape as a trade mark for snacks, and, second, that it was not possible to establish from the documents submitted that the contested mark had been genuinely used. The EUTM proprietor appealed to the General Court (GC), relying on three pleas in law: (i) infringement of Article 58(1)(a) EUTMR, (ii) of Article 58(1)(a) EUTMR in conjunction with Article 18(2) EUTMR and (iii) of Article 58(1)(a) EUTMR in conjunction with Article 18(1)(b) EUTMR. **Proof of use of the trade mark.** The evidence submitted by the EUTM proprietor does not prove genuine use of the three-dimensional mark in the form of a kangaroo (para. 47). To start with, part of the evidence does not have to do with the question of the use of the contested mark (para. 35). Some of the items of evidence do not concern the relevant period (paras 36-38). Insofar as the images of the packaging of the products submitted as evidence of use are concerned, it must be considered that the packaging in question contains word elements, such as 'jumpy's', 'funny frisch', 'wolf' or 'wolf intersnacks', or the figurative element of a stylised silhouette of a kangaroo, and it is these elements that dominate the foreground of the packaging of the products, whereas the two-





dimensional representations of the contested mark appear as an ancillary figurative element, even marginal, in the background of the packaging. Therefore, the consumer is likely to perceive the goods as coming from the company identified by the verbal and figurative elements present on the abovementioned packaging, which, because of their size, colour and proportions, will draw their attention more than the two-dimensional representation of the contested mark (para. 39). Since the package is not transparent, the snacks inside were not examined. A market survey titled 'Reputation and distinctiveness of salty snacks that look like the form of a kangaroo', which was carried out in Germany in January 2015 by an independent company, shows that this shape for snacks was known by about 60 % of the people consulted, but only half of them perceived the snacks in the three-dimensional form of a kangaroo as coming from a specific company. In particular, the market survey concluded that less than one third of those surveyed associated snacks in the shape of three-dimensional kangaroos with the different brands used by the cancellation applicant (paras 42-45). **Use of the mark with the consent of its proprietor.** The question of whether the cancellation applicant used the mark or not with the consent of the proprietor is irrelevant, as it cannot alter the already reached conclusion that the submitted evidence was insufficient to prove genuine use (para. 51). **Proof of use of the contested mark for export purposes.** Even if it were true that the BoA had not examined the evidence of use of the contested mark for export purposes, the corresponding plea in law would be ineffective as the evidence of use of the mark for export is subject to the same objections already discussed in relation to the first plea (paras 55-56). The action of the proprietor must be dismissed and consequently its EUTM is revoked.

**T-831/17; Flexagil (fig.); DRH Licensing & Managing AG v EUIPO**; Judgment of 15 November 2018; EU:T:2018:791; Language of the case: DE. The EUTM proprietor registered the figurative mark 'Flexagil' as an EUTM for goods in Classes 5, 23 and 30. A revocation application was filed pursuant to Article 58(1)(a) EUTMR. The Cancellation Division (CD) upheld the revocation application, and it found that proof of genuine use of the trade mark for the goods in Class 5 had not been provided. The EUTM proprietor appealed and the Board of Appeal (BoA) upheld the appeal, insofar as it found that sufficient proof of genuine use had been provided. The revocation applicant appealed to the General Court (GC), relying on a single plea in law: infringement of Article 58(1)(a) EUTMR. Insofar as the images contain the further component 'krem', this addition, as a mere reference to the goods as a cream, does not alter the distinctive character of the trade mark as 'krem' is the Hungarian word for cream (para. 38) That element only describes the form of the product and merely informs the consumer that the goods are not in gel, oil, or spray form (para. 37). (ii) The invoices are related to advertisements in numerous Hungarian media outlets and they contain the word element of the contested mark, as well as the relevant period and the investment made. Admittedly, some invoices do not refer to the relevant period and others appear to be duplicated. Nevertheless a large number of invoices were produced covering the relevant period (para. 43). The BoA did not err in taking into account all the invoices in which the word mark 'flexagil' appeared and which related to the relevant period (para. 44). (iii) The large number of submitted invoices and the size of the invoiced sums for the respective advertising campaigns, clearly show that the use of the trade mark was not merely token use (para. 58). (iv) The size of a proprietor's undertaking is irrelevant for the purposes of determining from what point use of a trade mark may be classified as genuine. If, in order for use to be genuine, it must be directed at creating an opening in the market for the goods or services identified by the mark, the intensity of use will depend, on the nature of the goods or services and on the structure and size of the relevant market, though not on the size of the undertaking that owns it, who may not be the user of the mark (para. 61). (v) It is not necessary that the mark should be used in an extensive geographic area for the use to be deemed genuine (para. 65). Since the



assessment of whether the use of the trade mark is genuine is carried out by reference to all the facts and circumstances relevant to establishing whether the commercial exploitation of the mark serves to create or maintain market shares for the goods or services for which it was registered, it is impossible to determine a priori, and in the abstract, what territorial scope should be chosen in order to determine whether the use of the mark is genuine or not. A *de minimis* rule, which would not allow the national courts in the EU to appraise all the circumstances of the dispute before it, cannot therefore be laid down (para. 66). Genuine use in one Member State, Hungary, was sufficient to keep the mark on the register.

♦[T-253/17](#); **EIN KREIS MIT ZWEI PFEILEN (fig.)**; *Der Grüne Punkt — Duales System Deutschland GmbH v EUIPO*; Judgment of 12 December 2018; EU:T:2018:909; Language of the case: DE. The EUTM proprietor registered the collective figurative mark 'EIN KREIS MIT ZWEI PFEILEN' as an EUTM for goods and services in Classes 1 to 42. The regulations governing use of the mark that had been submitted with the application for registration state, inter alia, in point 6, that the mark had been created 'to enable consumers and businesses to recognise packaging included in the dual system and for which a sum had been paid towards financing the system, as well as goods packaged in this way, and to distinguish them from other packaging and goods ...' A revocation application was filed pursuant to Article 58 EUTMR. The Cancellation Division (CD) partially upheld the revocation application, namely for all the goods in Classes 1 to 34 with the exception of those consisting of different forms of packaging in Classes 6, 17, 18, 20, 21, 22 and 24. The proprietor filed an appeal, which the Board of Appeal (BoA) dismissed. It found that the owner had not proved that, in relation to goods other than packaging, it had used the contested mark in accordance with its basic function, namely to guarantee the origin of the contested goods. Furthermore, the owner had not succeeded in proving that the purpose of the use of the contested mark was to create or maintain an outlet for those goods. All the documents produced related to the use of the contested mark exclusively with regard to sales packaging. The proprietor appealed to the General Court (GC), relying on a sole plea in law: infringement of Article 18(1) EUTMR in conjunction with Article 74 EUTMR. **Proof of use.** Proof of genuine use of the contested mark on packaging may constitute proof of genuine use of the mark for the packaged goods themselves if the proprietor proves that the relevant public perceives such use of the mark on the packaging as constituting use as a mark, that is, as an identifier of the commercial origin, for the packaged goods (paras 34-35). **Relevant public.** The contested goods primarily targeted the general public but also to some extent specialists in the fields of agriculture, commerce and industry. This target public would pay a normal to high level of attention when purchasing the goods (para. 36). From the point of view of the relevant public, the proprietor had not proved that it had used the contested mark in accordance with a mark's basic function of guaranteeing the identity of origin of the contested goods (para. 37). Rather, the relevant public understood the use of the mark on the packaging as an indication that the packaging could be collected and reused according to a certain system, namely the 'dual system' (para. 38). The relevant public was perfectly capable of distinguishing between a mark that indicated the commercial origin of goods and a mark that indicated the recovery of empty and used packaging after the consumer had unpacked, used or consumed the goods themselves, even if packaging and goods appeared to be a 'unit' at the time of sale. Moreover, the evidence adduced by the proprietor showed that the goods themselves were regularly designated by marks belonging to different companies (para. 41). It followed that use of the contested mark as a collective mark designating the goods of the members of an association to distinguish those goods from those of undertakings that were not part of that association would be perceived by the relevant public as use relating to packaging. The intangible quality claimed by the proprietor and attributed to the contested mark, that is to



say the ecological behaviour of the undertaking by virtue of its affiliation to the proprietor's licence agreement system, would be attributed by the relevant public to the fact that the packaging could be ecologically treated and not to such treatment of the packaged goods themselves (para. 42). Consequently, how the contested mark was understood by the relevant public did not relate to an intangible quality of the contested goods, but to an intangible quality of the packaging of those goods, namely that the packaging belonged to the dual system administered by the proprietor (para. 43). Since the mark was known to the consumer only as an indication that the packaging waste designated by the mark could be disposed of through local collection facilities, the affixing of the contested mark on the packaging simply expressed the fact that the company concerned, and all other economic operators using the same mark on their packaging, complied with the requirements laid down in Directive 2008/98/EC on waste management (para. 44). In the unlikely event that the offers of competitors' goods were identical, and the consumer were to decide his or her purchase merely on the basis of the quality of the packaging, the contested mark would not be creating or maintaining an outlet vis-à-vis other economic operators for the packaged goods, but only for the packaging itself (para. 45). The proprietor had therefore not proved genuine use of the mark for the contested goods; consequently, the action had to be dismissed (para. 46).

**T-672/16; C=commodore (fig.); C=Holdings BV v EUIPO**; Judgment of 13 December 2018; EU:T:2018:926; Language of the case: EN

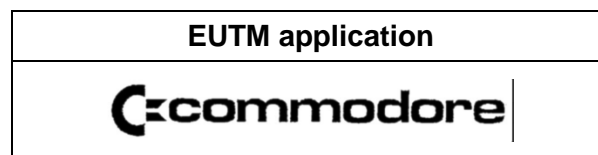

The predecessor in title to the applicant obtained the international registration (IR) of the figurative sign above for goods and services in Classes 9, 25, 38 and 41. The defendant filed an application for invalidity and sought the revocation of the applicant's rights to the IR on the basis that it had not been genuinely used as an EU trade mark for a continuous period of five years. The Cancellation Division (CD) upheld the application for revocation for all the IR's goods and services. The Board of Appeal (BoA), however, considered that the mark had been used for part of the goods in Class 9 but not for the rest of the goods and services and that there were no proper reasons for this non-use. The applicant filed an action with the General Court (GC), relying on a single plea in law: infringement of the provisions of Article 18(1) and (2) EUTMR and of Article 58(1)(a) EUTMR and infringement of Article 17 of the Charter of Fundamental Rights of the EU and of Articles 94 and 95 EUTMR. The BoA did not find in the contested decision that the circumstances relied on by the applicant did not present a sufficiently direct relationship with the contested mark (para. 37). According to the BoA, the applicant did not explain why the use of that registration as an EU trade mark was possible for some goods (in Class 9) and not for the other goods or services in question. Consequently, the applicant itself established that the alleged reason for non-use of its IR did not prevent genuine use (para. 39). The mere fact that genuine use of the contested mark was possible for certain goods did not exclude the existence of proper reasons for non-use of that mark for other goods or services (para. 40). The existence of genuine use for some of the contested mark's goods and services does not preclude, in law or fact, the presence of proper reasons for non-use of the same mark in relation to its other goods or services (para. 41). The BoA did not take the chronology of events into account. Indeed, the licensing agreement, which established genuine use of the IR for the goods listed, was concluded before the transfer of ownership. The first ground of



the contested decision is, therefore, vitiated by an error of law and an error of assessment (para. 42). The BoA criticised the applicant for not having adduced any evidence showing that it was prevented from using the IR at issue. The BoA therefore disregarded the fact that the sole activity of the applicant was in fact the conclusion of licensing agreements (para. 44). The BoA erred in requiring the applicant to demonstrate that the circumstances upon which it relied made any negotiations with other potential licence holders ‘impossible’ (para. 46). Furthermore, it did not take into account the fact that an existing customer had decided to freeze the payment of its royalties to the applicant. Therefore, the BoA could not, without committing an error of assessment, criticise the applicant for failing to adduce evidence of other licence holders, although it had established that an existing trading partner had stopped the payment of royalties (paras 47-48). The third ground put forward by the BoA is vitiated both by an error of law and an error of assessment (para. 49). According to the BoA, it is apparent from the court documents produced that the applicant could not have any serious doubts as to its property rights for the Commodore trade mark (para. 50). However, the BoA failed to examine whether all the manoeuvres in question, which it described as ‘fraudulent’ and ‘intimidatory’, could give rise to doubt in the minds of third parties (para. 52). The BoA does not explain how an obstacle, which it categorised itself as ‘considerable’, could not, in the normal course of business, seriously undermine the appropriate use of the contested mark (para. 55). The fourth ground is also, therefore, vitiated by errors of law and assessment (para. 57). The manoeuvres described (some of which took place within the EU) were capable of influencing the use of the IR for all the goods and services in question (para. 59). None of the grounds of the contested decision, taken separately or as a whole, provide a basis for that decision, either in fact or in law (para. 61). It follows that it is necessary to uphold the single plea in law without it being necessary to examine the other complaints put forward by the applicant and, on that basis, to annul the contested decision (para. 69).

## B. Article 59(1)(b) EUTMR — Bad Faith

♦[T-207/17](#); **hp (fig.)**; *Senetic S.A. v EUIPO*; Judgment of 24 April 2018; EU:T:2018:396; Language of the case: EN



The intervener applied for an EU trade mark for the figurative mark above for goods and services in Classes 2, 7, 9, 16, 35 to 38 and 40 to 42. The applicant applied for a declaration of invalidity on the basis of Article 59(1)(a) EUTMR, read in conjunction with Article 7(1)(b) and (c) EUTMR, and Article 59(1)(b) EUTMR. The Cancellation Division (CD) dismissed the application in its entirety and the applicant appealed this decision. The Board of Appeal (BoA) dismissed the appeal as it cannot be generally stated that a mark lacks distinctiveness because of any of the following reasons: it consists of one or two letters; the letters ‘hp’ play a dominant role and are not descriptive or lacking in distinctiveness; the



applicant did not prove that the contested mark was descriptive or lacking in distinctiveness at the time of registration. The applicant appealed to the General Court (GC) relying on three pleas in law: (i) infringement of Article 59(1)(a) EUTMR, read in conjunction with Article 7(1)(c) EUTMR; (ii) infringement of Article 59(1)(a) EUTMR, read in conjunction with Article 7(1)(b) EUTMR; and (iii) infringement of Article 59(1)(b) EUTMR. **On the third plea in law.** The applicant did not submit evidence that the intervener had filed the application for registration of the contested mark in bad faith (para. 64). In fact, the applicant did not submit any evidence establishing the objective circumstances in which the intervener allegedly knew that some of the goods and services concerned were marketed by the applicant or other third parties under a similar or identical sign (para. 65). The applicant's assertions that evidence of bad faith on the part of the intervener is easier to establish owing to the descriptive character of the contested mark are unfounded since, as is apparent from the examination of the first and second pleas, the applicant has not proved that the contested mark is descriptive or lacking distinctiveness (para. 66). The applicant did not establish the intervener's intention to prevent the marketing of a product by a third party without using the mark applied for (para. 67).

♦[T-208/17](#); **HP**; *Senetic S.A. v EUIPO*; Judgment of 24 April 2018; EU:T:2018:216; Language of the case: EN. The intervener applied for an EUTM for the word mark **HP** for goods and services in Classes 2, 7, 9, 16, 35 to 38 and 40 to 42. The invalidity applicant filed an invalidity application on the basis of Article 59(1)(a) EUTMR read in conjunction with Article 7(1)(b) and (c) EUTMR. The Cancellation Division (CD) dismissed the invalidity application in its entirety and the applicant appealed this decision. The Board of Appeal (BoA) dismissed the appeal as it cannot be generally stated that a mark lacks distinctiveness because it consists of one or two letters. Further, the letters 'hp' play a dominant role and cannot be considered descriptive or lacking distinctiveness. The BoA found that the invalidity applicant had neither proved that the contested mark was descriptive, nor lacking distinctiveness at registration. The EUTM applicant filed an action relying on three pleas in law: (i) infringement of Article 59(1)(a) EUTMR read in conjunction with Article 7(1)(c) EUTMR; (ii) infringement of Article 59(1)(a) EUTMR, read in conjunction with Article 7(1)(b) EUTMR; and, (iii) infringement of Article 59(1)(b) EUTMR. **The third plea in law.** The applicant did not submit any evidence establishing the objective circumstances in which the intervener allegedly knew that some of the goods and services were marketed by the applicant or by other third parties under a similar or identical sign. It is apparent from the Office's administrative file that the applicant did not submit any evidence that, at the time of filing the application for the contested mark, a third party was actually using a similar or identical sign in marketing its goods or services (para. 63). The applicant's assertions that evidence of bad faith on the part of the intervener is easier to establish owing to the descriptive character of the contested mark cannot be founded. This is apparent from the examination of the first and second pleas. Further, the applicant did not prove that the contested mark was descriptive or lacking distinctiveness (para. 64). The applicant did not establish the intervener's intention to prevent the marketing of a product by a third party without using the sign which it had applied to register (para. 65).



♦ **T-340/16; Outsource 2 India (fig.); Flatworld Solutions Pvt Ltd v EUIPO**; Judgment of 31 May 2018; EU:T:2018:314; Language of the case: EN

EUTM	Earlier rights (logo and domain name, respectively)
	

The EUTM proprietor was granted registration of the EUTM above for services in Classes 35, 36 and 42. An invalidity application was filed pursuant to Article 59(1)(b) EUTMR. The Cancellation Division (CD) upheld the application, considering that the proprietor had intentionally sought to appropriate the applicant's mark and thus acted in bad faith when filing for registration. The Board of Appeal (BoA) upheld the proprietor's appeal, considering that the proprietor had not acted in bad faith or with dishonest intent when it registered the contested mark. The applicant appealed to the General Court (GC) relying on a single plea in law: infringement of Article 59(1)(b) EUTMR. **Objective circumstances of the case.** When examining the legality of the contested decision, it is necessary to start by recalling the objective circumstances of the case according to the evidence adduced by the proprietor and undisputed by the applicant, and as set out by the parties in their written pleadings (para. 28). **Chronology of events.** Prior to 2006, the applicant was providing outsourcing services using the logo and domain address above. On 4 November 2006 the proprietor contacted the applicant to discuss cooperation, particularly in Germany, and was immediately provided with a login and password for the applicant's website. The parties continued negotiating, with the proprietor visiting the applicant's headquarters in India in February 2007 (para. 29). Finding it difficult to reach an exclusivity agreement, the applicant offered to cooperate on a case-by-case basis over a six-month period, to determine whether the German market was suited to the expansion of its activities; in which case the parties could then sign a memorandum of understanding (para. 30). On 19 May 2007, the proprietor acknowledged that it had undertaken not to use the applicant's logo or website in the event of cooperation on a case-by-case basis and that it had therefore redesigned its website and registered its company in the United Kingdom and Germany under the name Outsource2India Ltd, with its own trade mark and logo (para. 31). On 25 May 2007, the applicant replied that it had expected the proprietor to register using a company name and website different from its own. It also stated that the similarities between the contested mark and its non-registered mark *outsource2india* were too significant to allow trouble-free relations between their two companies, and that the proprietor was intentionally seeking to further its own interests by taking advantage of the applicant's non-registered mark *outsource2india*. Consequently, the applicant broke off relations with the proprietor and worked with other European partners, in particular German ones (para. 32). On 25 June 2007, the proprietor applied for the EUTM above. **Factors to be examined.** As well as the events chronology, it is appropriate to examine the proprietor's knowledge of the applicant's use of the non-registered mark *outsource2india*, the proprietor's intention and the commercial logic it pursued (para. 37). **Knowledge.** Contrary to the BoA's conclusion, the applicant was actually marketing its outsourcing services in Germany using the wording 'outsource2india' at the time the proprietor filed the contested mark, and did so through its website, which was not merely intended to provide information. Therefore, the proprietor was aware of the applicant's activities under its non-registered mark *outsource2india* and its intention to develop its business, including through possible cooperation with the proprietor,



in the European Union and in particular in Germany, when it filed the contested mark (paras 39-40). **Intention.** The objective circumstances of the case show that there was a certain link between the parties, in the form of contract negotiations, and that, by attempting to register a sign similar to that used by the applicant, for identical services, even though the applicant had informed the proprietor that the two signs displayed too many similarities, the proprietor intended to exploit the economic potential of the applicant's non-registered trade mark *outsorce2india*. **Commercial logic.** By continuing to use and emphasise, after the definitive breakdown of negotiations, the wording 'outsorce2india', both in the name of its mark and that of its company, even though the applicant had not given its consent, the proprietor sought, when it filed the contested mark, to further its own interests in order to develop the use of the non-registered mark *outsorce2india* in the European Union and thus pursued its own commercial logic (para. 46). **Global assessment of bad faith.** Irrespective of whether the wording 'outsorce2india' is descriptive, since the application was submitted on the basis of Article 59(1)(b) EUTMR, the proprietor knew that the applicant was using that wording in its logo, in its non-registered mark and in its domain names. In particular, the proprietor contacted the applicant specifically to establish collaboration, particularly in Germany, in developing the applicant's business through the use of that wording. In addition, the proprietor filed to register the contested mark shortly after the termination of its pre-contractual relationship with the applicant. All of these factors demonstrate its bad faith, particularly as it had, moreover, registered its company and its mark in Germany and the United Kingdom beforehand (para. 48).

**T-374/17; Cuervo y Sobrinos LA HABANA 1882 (fig.) / CUERVO Y SOBRINO et al.;** *Cuervo y Sobrinos 1882, S.L. v EUIPO*; Judgment of 10 October 2018; EU:T:2018:669; Language of the case: ES

EUTM	Earlier trade marks
	<p style="text-align: center;"><b>CUERVO Y SOBRINO</b></p>

The EUTM proprietor obtained registration of the figurative mark above as an EUTM for *jewellery, horological and chronometric instruments* in Class 14, *pens, pencils* in Class 16, *wallets, purses, briefcases* in Class 18 and *clothing, footwear, headgear* in Class 25. An invalidity application was filed pursuant to Article 59(1)(b) EUTMR and Article 60(1)(a) EUTMR in conjunction with Article 8(1)(b) EUTMR, based on two Spanish word marks, both for the sign **CUERVO Y SOBRINO**, for *jewellery, hardware, silverware, imitation jewellery, watches, accessories and supplies for watches* in Class 14 and *stylographs, ballpoint pens, mechanical pencils and office requisites* in Class 16. The Cancellation Division (CD) upheld the invalidity application on the basis of Article 59(1)(b) EUTMR. The proprietor appealed. The Board of Appeal (BoA) partially upheld the appeal insofar as the CD had upheld the application for a declaration of invalidity for the goods in Classes 18 and 25. It found, first, that there was a likelihood of confusion (LOC) with regard to the goods in Classes 14 and 16 since the signs were visually and phonetically very similar and the goods identical; second, that there was no LOC for the goods in Classes 18 and 25 since the goods were not similar; and, third, that the proprietor had not acted in bad faith, since the registration of



the contested mark was not incompatible with the contractual relations existing between the parties and did not cause prejudice to the interests of the invalidity applicant. The proprietor brought an action before the General Court (GC), relying on one single plea in law: infringement of Article 60(1)(a) EUTMR in conjunction with Article 8(1)(b) EUTMR. It submits that the signs at issue are not similar and that LOC is therefore also excluded for the goods in Classes 14 and 16. The invalidity applicant brought a cross-claim, relying on two grounds: (i) infringement of Article 60(1)(a) EUTMR in conjunction with Article 8(1)(b) EUTMR and, (ii) infringement of Article 59(1)(b) EUTMR. It claims that the goods in Classes 18 and 25 are similar to the earlier marks' goods and that there is therefore a likelihood of confusion also with regard to those goods. It furthermore contends that the proprietor acted in bad faith when the contested mark was filed. **The EUTM proprietor's action. Comparison of the signs.** Although in marks composed of word and figurative elements, the former must not always be considered more distinctive than the latter, in this case, especially due to its larger size and central position, the element 'Cuervo y Sobrinos' clearly has a bigger impact on the overall impression of the contested mark, as compared to the shield in the upper part of the sign and the descriptive word element 'La Habana 1882' in the lower part. As the dominant element of the contested mark 'Cuervo y Sobrinos' is almost identical to the purely denominative earlier trade marks 'Cuervo y Sobrino'. Indeed, the conflicting marks, as a whole, are very similar visually and phonetically with the result that there is LOC between them for the identical goods in Classes 14 and 16. Such a conclusion cannot be called into question by the fact that the level of attention of the relevant public is higher for the goods in Class 14 (paras 24-30). Accordingly, the proprietor's single plea must be rejected as unfounded (para. 31). **The invalidity applicant's cross-claim. Comparison of the goods.** The contested goods in Class 18, namely *wallets, purses and briefcases*, are different in nature, purpose and use to those of the earlier marks in Classes 14 and 16 and are not in competition or complementary. They are, therefore, not similar (para. 37). The contested goods in Class 25, namely *clothing, footwear, headgear*, cannot be regarded as similar to the invalidity applicant's goods in Classes 14 and 16 either (paras 35-36). This appreciation is not questioned by the fact that the parties had concluded a licence agreement on 14 November 2002 whereby the invalidity applicant granted authorisation to the proprietor to use the name CUERVO Y SOBRINO exclusively for wristwatches. The existence of such an agreement does not mean that consumers will consider it common practice for the goods covered by the contract to be marketed under the same brand. Furthermore, accepting that the existence of the licence agreement of 14 November 2002 is capable of establishing, on its own, a similarity between the goods covered by that contract would imply an absurd conclusion that, under certain circumstances, any product may be considered similar to any other, regardless of the characteristics of these goods. Therefore, the invalidity applicant's first ground must be rejected as unfounded. (paras 38-44). **Bad faith.** The contested mark was registered for goods in four classes, namely Classes 14, 16, 18 and 25. However, as regards the goods in Classes 14 and 16, the cross-claim has become devoid of purpose given that the annulment of the contested mark for those goods is confirmed by the court ruling on the only plea of the EUTM proprietor (paras 65-66). As regards the contested goods in Classes 18 and 25, the fact that the EUTM proprietor was already the owner of several earlier CUERVO Y SOBRINOS Italian and international marks at the time of filing the EUTM application suggests that the filing of the application for registration of the contested mark was part of a plausible commercial logic (paras 68-69). Furthermore, the licence agreement signed on 14 November 2002 for 15 years was presumably in force at the time of filing the contested mark, namely on 17 May 2012. Such an agreement restricted the licence exclusively to wristwatches and expressly prohibited the EUTM proprietor from using the CUERVO Y SOBRINO name for any other product or activity. However, the Regulation and Directive do not forbid, in principle, the registration of another





person's trade mark for different goods. The proprietor's bad faith can therefore not be deduced from the mere existence of a contractual prohibition as the one included in the licence agreement. Having regard to all these factors, it must be held that, as regards the goods in Classes 18 and 25, the applicant's bad faith at the time of lodging the contested mark has not been proved (paras 70-74). The action and the cross-claim are both unfounded.

♦[T-681/17](#); **KHADI / KHADI**; *Khadi and Village Industries Commission v EUIPO*; Judgment of 29 November 2018; EU:T:2018:858; Language of the case: EN. The EUTM proprietor registered the word mark **KHADI** as an EUTM for goods in Classes 3, 21 and 31. An invalidity application was filed pursuant to Article 59(1)(b) EUTMR, Article 59(1)(a) EUTMR in conjunction with Article 7(1)(g) and (i) EUTMR, Article 60(1)(a) EUTMR in conjunction with Article 8(1)(a) and (b) EUTMR, and Article 60(1)(c) EUTMR in conjunction with Article 8(4) EUTMR. The Cancellation Division (CD) dismissed the invalidity application. The invalidity applicant filed an appeal. The Board of Appeal (BoA) dismissed the appeal. It found that the applicant had not adduced proof of any of the grounds of invalidity relied on. The invalidity applicant filed an action with the General Court (GC), relying on five pleas in law: (i) infringement of Article 95(2) EUTMR, (ii) distortion of the evidence, (iii) infringement of Article 7(1)(g) and Article 59(1)(a) EUTMR, (iv) infringement of Article 7(1)(g) and Article 59(1)(a) EUTMR and (v) infringement of Article 59(1)(b) EUTMR. **Bad faith**. The BoA did not err in concluding that it had not been established that, when the application for registration of the contested mark was filed, the intention of the applicant for that registration was to usurp the invalidity applicant's reputation, inter alia, because no recognition or extensive use of the invalidity applicant's mark had been demonstrated (para. 79). The contested decision is not vitiated by any ground of unlawfulness and the action of the invalidity applicant must therefore be rejected (paras 81-82).

♦[T-682/17](#); **khadi Naturprodukte aus Indien (fig.) / KHADI et al.**; *Khadi and Village Industries Commission v EUIPO*; Judgment of 29 November 2018; EU:T:2018:856; Language of the case: EN



The EUTM proprietor registered the figurative mark above as an EUTM for, inter alia, goods in Class 3. An invalidity application was filed pursuant to Article 59(1)(b) EUTMR, Article 59(1)(a) EUTMR in conjunction with Article 7(1)(g) and (i) EUTMR, Article 60(1)(a) EUTMR in conjunction with Article 8(1)(a) and (b) EUTMR, and Article 60(1)(c) EUTMR in conjunction with Article 8(4) EUTMR. The Cancellation Division (CD) dismissed the invalidity application. The invalidity applicant filed an appeal. The Board of Appeal (BoA) dismissed the appeal. It found that the applicant had not adduced proof of any of the grounds of invalidity relied on. The invalidity applicant filed an action with the General Court (GC), relying on four pleas in law: (i) infringement of Article 95(2) EUTMR, (ii) distortion of the evidence, (iii) infringement of Article 7(1)(g) and Article 59(1)(a) EUTMR, and (iv) infringement of Article 59(1)(b) EUTMR. **Bad faith**. The BoA did not err in concluding





that it had not been established that, when the application for registration of the contested mark was filed, the intention of the applicant for that registration was to usurp the invalidity applicant’s reputation, inter alia, because no recognition or extensive use of the invalidity applicant’s mark had been demonstrated (para. 72). The contested decision is not vitiated by any ground of unlawfulness and the action of the invalidity applicant must therefore be rejected (paras 74-75).

♦[T-683/17](#); **Khadi Ayurveda / KHADI et al.**; *Khadi and Village Industries Commission v EUIPO*; Judgment of 29 November 2018; EU:T:2018:860; Language of the case: EN. The EUTM proprietor registered the word mark **Khadi Ayurveda** as an EUTM for, inter alia, goods in Class 3. An invalidity application was filed pursuant to Article 59(1)(b) EUTMR, Article 59(1)(a) EUTMR in conjunction with Article 7(1)(g) and (i) EUTMR, Article 60(1)(a) EUTMR in conjunction with Article 8(1)(a) and (b) EUTMR, and Article 60(1)(c) EUTMR in conjunction with Article 8(4) EUTMR. The Cancellation Division (CD) dismissed the invalidity application. The invalidity applicant filed an appeal. The Board of Appeal (BoA) dismissed the appeal. It found that the applicant had not adduced proof of any of the grounds of invalidity relied on. The invalidity applicant filed an action with the General Court (GC), relying on four pleas in law: (i) infringement of Article 95(2) EUTMR, (ii) distortion of the evidence, (iii) infringement of Article 7(1)(g) and Article 59(1)(a) EUTMR, and (iv) infringement of Article 59(1)(b) EUTMR. **Bad faith**. The BoA did not err in concluding that it had not been established that, when the application for registration of the contested mark was filed, the intention of the applicant for that registration was to usurp the invalidity applicant’s reputation, inter alia, because no recognition or extensive use of the invalidity applicant’s mark had been demonstrated (para. 71). The contested decision is not vitiated by any ground of unlawfulness and the action of the invalidity applicant must therefore be rejected (paras 73-74).

### C. Article 60(2) EUTMR — Other earlier rights

[T-183/17](#); **REPRESENTACIÓN DE HOMBRE EN TRAJE HISTÓRICO (fig.)**; *Menta y Limón Decoración, SL v EUIPO*; Judgment of 24 April 2018; EU:T:2018:213; Language of the case: ES

EUTM	Earlier right
	

The intervener registered the figurative mark above for the goods and services in Classes 3, 6, 9, 14, 16, 18, 20, 21, 24, 25, 28 to 35, 41 and 43. An application of invalidity was filed based on the earlier mark above for all the abovementioned goods and services pursuant to Article 60(2) EUTMR. The Cancellation Division (CD) declared that the contested mark was invalid. The intervener filed an appeal against the CD’s decision and the Board of Appeal (BoA) upheld it, cancelling the CD’s decision. It found that the relevant national law is manifestly insufficient to comply with Article 12(1)(b) EUTMDR. Furthermore,



the CD referred to Directive (EU) 2015/2436 of the European Parliament and of the Council of 16 December 2015 to approximate the laws of the Member States relating to trade marks on its own motion, constituting a procedural violation. The BoA also held that the cancellation applicant's only reference to the Directive at the appeal stage is belated and cannot be taken into account. Finally, the CD also made a procedural violation by taking a decision without identifying in a precise form any of the earlier rights. Instead the CD referred to them in general, using confusing and vague reasoning. The cancellation applicant filed an action before the General Court (GC) relying on a single plea in law: infringement of Article 60(2) EUTMR. The first alleged procedural defect relates to the CD basing its decision on Article 12 of Directive 98/71/EC of the European Parliament and of the Council of 13 October 1998 on the legal protection of designs. However, the cancellation applicant only relied on that provision before the BoA (para. 20). The CD should not have supplemented the cancellation applicant's arguments by referring to Article 12 of Directive 98/71/EC, which concerns the rights conferred by the registration of a design (para. 21). As the earlier rights are Spanish industrial designs, the protection is governed by Spanish law and the conflict between them and the contested mark must be assessed on the basis of the applicable national law and not of European Union law (para. 23). In its application for a declaration of invalidity, the cancellation applicant presented the conflict between the signs as a conflict between marks, resulting in the BoA finding that the CD should not have taken into account Article 12 of Directive 98/71/EC, which concerns the protection of designs (para. 25). Moreover, Article 9(1)(c) of Law No. 17/2001 of 7 December 2001 on Trade Marks (as amended up to Law No. 24/2015 of 24 July 2015, on patents) prohibits registration of signs that reproduce, imitate or transform creations protected by copyright or industrial property rights. This is not sufficient to establish that Spanish law confers to the owner of a Spanish industrial design the right to prohibit the use of a more recent EUTM (paras 29-30). Indeed, Article 60(2) EUTMR provides that the earlier right must give the holder the right to prohibit the 'use' of a more recent trade mark, but does not require that the earlier trade mark grant its owner the right to prohibit the 'registration' of the contested trade mark (para. 31). However, Article 9(1)(c) of law 17/2001 is reproduced under Title II of that law entitled 'Concept of trade mark and prohibition of registration', which only concerns the conditions for the registration of marks in Spanish law and not those of their use (para. 32). As the Office and the intervener submitted, the conflict between the contested mark and the earlier industrial designs must be decided on the basis of the rules governing the designs (para. 34). The BoA found that the indications and allegations made by the cancellation applicant were deficient as the only provision of national law relied on did not prohibit the use of the contested mark (para. 36). As the Office, intervener and the applicant submitted, it is Law No. 20/2003 of 7 July 2003 on the legal protection of industrial designs that determines to what extent a Spanish industrial design is protected and in which situation a sign may affect it (para. 43). The cancellation applicant initially relied on the provisions of Article 45(1) and Article 47(1) of Law No. 20/2003 without submitting any argument based on those provisions to refute the reasoning on which the contested decision is based (para. 45). The BoA found that the intervener could be confused by referring to the 'earlier designs' in general (para. 56). It follows from the foregoing that the action as a whole must be dismissed (para. 57).

#### D. Article 61 EUTMR — Acquiescence

♦ [T-150/17](#); **FLÜGEL / ... VERLEIHT FLÜGEL et al.**; *Asolo Ltd v EUIPO*; Judgment of 4 October 2018; EU:T:2018:641; Language of the case: EN. The predecessor in title of the EUTM proprietor registered the word mark **FLÜGEL** as an EUTM for *beers; mineral and aerated waters and other non-alcoholic drinks; fruit drinks and fruit juices; syrups and other*



*preparations for the preparation of drinks* in Class 32 and *alcoholic drinks (except beers)* in Class 33. An invalidity application was filed pursuant to Article 60(1)(a) EUTMR in conjunction with Article 8(1)(b) and Article 8(5) EUTMR. It was based on, inter alia, the earlier Austrian word mark **...VERLEIHT FLÜGEL** for *energy drinks* in Class 32. The Cancellation Division (CD) upheld the invalidity application in its entirety. In light of the repute of the earlier mark **...VERLEIHT FLÜGEL** and considering the possibility that the proprietor of the contested mark could take unfair advantage of that earlier mark, the CD accepted the request for a declaration of invalidity insofar as based on Article 60(1)(a) EUTMR in conjunction with Article 8(5) EUTMR. Furthermore, although the invalidity applicant was aware of the existence of the contested mark, it had not been demonstrated that the invalidity applicant had acquiesced in its use in Austria and been aware of it during the relevant period in this case, namely from 5 December 2006 to 5 December 2011. The proprietor filed an appeal, which the Board of Appeal (BoA) dismissed. However, the BoA did not assess Article 60(1)(a) EUTMR in conjunction with Article 8(5) EUTMR, since it found that there was a likelihood of confusion (LOC) with the earlier mark **...VERLEIHT FLÜGEL** on the basis of Article 8(1)(b) EUTMR. Therefore, it annulled point 2 of the operative part of the CD decision to the extent that examination under Article 8(5) EUTMR was not necessary. The BoA considered that the signs were similar to an average degree and the earlier mark's *energy drinks* were in part identical and in part similar to an average degree to all the goods of the contested mark. It also found that the evidence submitted by the proprietor was not sufficient to conclude that there had been acquiescence on the part of the invalidity applicant. The proprietor appealed to the General Court (GC), relying on two pleas in law: (i) infringement of Article 61(2) EUTMR and (ii) infringement of Article 60(1)(a) EUTMR in conjunction with Article 8(1)(b) EUTMR. **Scope of the contested decision.** By basing the invalidity of the contested mark on a ground different from that favoured by the Cancellation Division, the BoA merely substituted its own assessment for that of the Cancellation Division, thus exercising its powers under Article 71 EUTMR (para. 24). **Acquiescence.** The BoA rightly held, on the basis of all the information in the file, that the evidence adduced by the proprietor (before both the CD and the BoA) concerning the invalidity applicant's actual knowledge of the use of the contested mark in Austria was insufficient for the purposes of establishing that there had been acquiescence in that use within the meaning of Article 61(2) EUTMR. That is to say that the proprietor of the earlier mark had actually (and not just potentially) been aware of the use of the contested mark (paras 41-51).

---

## VI. DESIGNS

### A. Registration proceedings



[C-217/17 P](#); **Becher**; Judgment of 5 July 2018; EU:T:2018:534; Language of the case: DE. The appellant applied to register two Community designs for *beakers* in Class 07-01. The Office informed the appellant that the product indication did not match the representations filed, as these also showed bottles. The appellant replied that no protection was sought for the bottles reproduced in the representations, and proposed changing the indication to *Drinking beakers as receptacles for a bottle which is part of those beakers*. The Office responded that although it was clear that the latter was not seeking any protection for the bottles, they appeared clearly on the representations, and due to their presence, the characteristics for which protection was sought were not clearly visible. (para. 17). The appellant argued that the conditions for the attribution of a date of filing were satisfied, since the representations filed showed the designs against a neutral background. The Office stated that it was maintaining the decision since the representations showed a beaker and



a bottle. The Office informed the appellant that they could remedy the deficiencies in the applications by either filing new views or adding the indication *bottles* and dividing the multiple application. The appellant filed an appeal pursuant to Articles 55 to 60 CDR. The Board of Appeal confirmed that it was not possible to determine from the representation of the two designs concerned whether protection was being sought for the beaker, the bottle, or a combination of the two. The appellant filed an action with the General Court (GC) relying on a single ground of appeal, alleging infringement of Articles 45 and 46 CDR. The wording of Article 36(1)(c) CDR provides that the application for registration of a design must contain a ‘representation of the design suitable for reproduction’. That wording seems to emphasise the technical quality of the representation. However, the concept of representation encompasses, in itself, the idea that the design must be clearly identifiable (para. 49). This is confirmed by the teleological interpretation of that provision, which must contribute to the proper functioning of the system of registration of designs. Accordingly, the function of the graphic representation requirement is, in particular, to define the design itself in order to determine the precise subject of the protection afforded by the registered design to its proprietor (para. 52). The competent authorities must know with clarity and precision the nature of the constituent elements of a design in order to be able to fulfil their obligations in relation to the prior examination of applications for registration and the publication and maintenance of an appropriate and precise register of designs (para. 53). Furthermore, economic operators must be able to acquaint themselves, with clarity and precision, with registrations or applications for registration made by their current or potential competitors and thus obtain relevant information about the rights of third parties (para. 54). This conclusion is confirmed by the fact that obtaining a filing date enables the proprietor of the design concerned to benefit from the right of priority (para. 56). It follows from the above considerations that the appellant’s sole ground of appeal is unfounded and, consequently, it must be dismissed and the appeal must be dismissed in its entirety (para. 64).

## B. Invalidity proceedings and grounds for invalidity

♦ [T-793/16](#); **Boxes [packaging]**; *Şölen Çikolata Gıda Sanayi ve Ticaret AŞ v EUIPO*; Judgment of 7 February 2018; EU:T:2018:72; Language of the case: EN

RCD application	Earlier RCD
	 <p data-bbox="1034 1552 1099 1581">No 1</p>  <p data-bbox="1034 1753 1099 1783">No 2</p>

The intervener registered the Community design above for Class 09-03 (*boxes [packaging]*). The applicant filed an application for invalidity on the grounds set out in (i) Article 25(1)(e) CDR, invoking international registration No 1 148 957 designating, among other Members States, Bulgaria and registered for goods in Class 30 (*cocoa, cakes, chocolates, chocolate creams, cakes with cocoa milk, chocolate cream*) for the figurative mark above as earlier right No 1, and as set out in (ii) Article 25(1)(f) CDR claiming





copyright-protection under Bulgarian law the figurative mark above as earlier right No 2. The Invalidity Division (ID) rejected the application for a declaration of invalidity because it found that there was no likelihood of confusion (LOC) on the part of the relevant public and that the existence and extent of the protection of the work claimed had not been proved under the relevant legislation, namely United Kingdom law. The applicant filed an appeal against the ID's decision. The Board of Appeal (BoA) dismissed the appeal. First, it assessed whether there was LOC on the part of the relevant public. BoA found that the earlier mark's goods were intended for the general public in Bulgaria, whereas the product portrayed by the contested design was directed at professional consumers in the confectionery industry. With regard to the goods, it was found that they are similar. As regards the comparison of the signs at issue, it found that the earlier mark and the contested design were visually and phonetically dissimilar, as the common element 'cornet' was descriptive and not distinctive and consumers will not pay any attention to it. It considered that they were similar only from the conceptual perspective, insofar as they both refer to a cornet. Finally, BoA added that it had not been established that the earlier mark had acquired an enhanced distinctive character in Bulgaria. Therefore, it was concluded that there was no LOC on the part of the relevant public and rejected the application for invalidity based on Article 25(1)(e) CDR. Regarding Article 25(1)(f) CDR, the BoA found that the applicant had not established that the work invoked was protected by copyright and rejected that claim. In its application before the GC the applicant raised three pleas in law: (i) infringement of Article 25(1)(e) CDR (ii) infringement of Article 25(1)(f) CDR, (iii) infringement of Article 62 and Article 63(1) CDR. **Relevant public.** The goods in question target the Bulgarian general public who, given the nature of the goods, will have a reduced level of attention (paras 29-35). **Comparison of goods.** The goods are complementary and, therefore, similar as the box portrayed by the contested design was intended for stocking and displaying edible cones and that the earlier mark had been registered for various items of confectionery, inter alia, *chocolate creams* (para. 39). **Comparison of signs.** (i) distinctive and dominant elements: the element composed of the words 'bobo' and 'cornet' on the contested design will capture the relevant public's attention more than the rabbit portrayed on the design, which, contrary to the intervener's assertion, plays a minor role in the overall impression conveyed by the design (para. 51). Only Bulgarian consumers with knowledge of English, or any other language in which the word 'cornet' exists and has the same meaning, will understand that that word designates the goods wrapped in packaging in the form of a cone. However, it has not been established that that word forms part of the basic vocabulary in English or in any other language which will be understood by a large part of the relevant public in Bulgaria (para. 54). Therefore, contrary to the findings of BoA the word 'cornet' is not totally devoid of distinctive character (para. 56). In the signs at issue the words 'bobo', 'ozmo' and 'cornet' are written in very visible bold letters and are of the same width (para. 58). Even though the word 'cornet' does not, in itself, dominate the overall impression conveyed by the signs at issue and is not especially distinctive, it cannot, on account, in particular, of its position in the signs and its size, be regarded as playing a negligible role in the overall impression conveyed by the signs. Accordingly, due account must be taken of it when comparing the signs (para. 60). (ii) Visual comparison: the contested design and the earlier mark are both made up of two words, 'bobo' and 'cornet', and 'ozmo' and 'cornet', respectively. The word 'cornet' is therefore common to both. Moreover, the words 'bobo' and 'ozmo' are of the same length and each contains the letter 'o', which appears twice, once at the end of each word. Therefore, they have considerable similarities (paras 63-64). The contested design and the earlier mark are also different in certain respects (paras 65-68). Nevertheless, the elements which differentiate the signs at issue visually do not outweigh the considerable similarities between those signs that will be perceived by consumers. Therefore, the BoA erred in taking the view that those signs are visually different (para. 69). (iii) Phonetic comparison:



the signs at issue have an average degree of phonetic similarity due to the word ‘cornet’ and that the contested design and the earlier mark have the same number of words with the same number of syllables and the same number of letters, with the appearance of the letter ‘o’ in both words ‘bobo’ and ‘ozmo’ (paras 73-74). (iv) Conceptual comparison: the part of the relevant public that does not understand the meaning of the common word ‘cornet’ cannot attribute any particular meaning to the signs at issue. Accordingly, it is not possible to make a conceptual comparison of the signs for this part of the public (para. 77). The representations of a rabbit, other animals and food products in the form of cones, which are present on the contested design but not on the earlier mark cannot introduce conceptual difference between the signs because they will play only a minor role in the overall impression of the contested design (para. 78). In conclusion, contrary to the position reached by the BoA, the signs at issue are visually highly similar, have an average degree of phonetic similarity and are conceptually similar for the members of the relevant public who understand the meaning of the word ‘cornet’ but they are not for the rest of the public who does not attribute any meaning to that word (para. 79). **LOC**. There is LOC on the part of the relevant public (para. 82). There is no need to examine the second plea as the first has been upheld (para. 84).

♦ **T-794/16; Ice cream cornets [edible] (Packagings for -); Şölen Çikolata Gıda Sanayi ve Ticaret AŞ v EUIPO**; Judgment of 7 February 2018; EU:T:2018:70; Language of the case: EN

RCD	Earlier RCDs
	 <p data-bbox="1034 1182 1098 1211">No 1</p> <p data-bbox="1034 1402 1098 1431">No 2</p>

The intervener registered the Community design above for Class 09-05 (*ice cream cornets [edible] (packagings for)*). The applicant filed an application for invalidity on the grounds set out in (i) Article 25(1)(e) CDR, invoking international registration No 1 148 957 designating, among other Members States, Bulgaria and registered for goods in Class 30 (*cocoa, cakes, chocolates, chocolate creams, cakes with cocoa milk, chocolate cream*) for the figurative mark above as earlier right No 1, and as set out in (ii) Article 25(1)(f) CDR claiming copyright-protection under Bulgarian law for the figurative mark above as earlier right No 2. The Invalidity Division (ID) rejected the application for a declaration of invalidity because it found that there was no likelihood of confusion (LOC) on the part of the relevant public and that the existence and extent of the protection of the work claimed had not been proved under the relevant legislation, namely United Kingdom law. The applicant filed an appeal against the ID’s decision. The Board of Appeal (BoA) dismissed the appeal. First, it assessed whether there was LOC on the part of the relevant public. BoA found that the earlier mark’s goods were intended for the general public in Bulgaria, whereas the product portrayed by the contested design was directed at professional consumers in the confectionery industry. With regard to the goods, it was found that they are similar. As regards the comparison of the signs at issue, it found that the earlier mark and the



contested design were visually and phonetically dissimilar, as the common element 'cornet' was descriptive and not distinctive and consumers will not pay any attention to it. It considered that they were similar only from the conceptual perspective, insofar as they both refer to a cornet. Finally, BoA added that it had not been established that the earlier mark had acquired an enhanced distinctive character in Bulgaria. Therefore, it was concluded that there was no LOC on the part of the relevant public and rejected the application for invalidity based on Article 25(1)(e) CDR. Regarding Article 25(1)(f) CDR, the BoA found that the applicant had not established that the work invoked was protected by copyright and rejected the claim. In its application before the GC the applicant raised three pleas in law: (i) infringement of Article 25(1)(e) CDR (ii) infringement of Article 25(1)(f) CDR, (iii) infringement of Article 62 and Article 63(1) CDR. **Relevant public.** The goods in question target the Bulgarian general public who, given the nature of these goods, will have a reduced level of attention (paras 29-35). **Comparison of goods.** The goods are complementary and, therefore, similar as the packaging in the form of a cone portrayed by the contested design was intended as packaging for edible cones filled with ice cream and that the earlier mark had been registered for various items of confectionery, inter alia, *chocolate creams* (para. 39). **Comparison of signs.** (i) distinctive and dominant elements: the element composed of the words 'bobo' and 'cornet' on the contested design will capture the relevant public's attention more than the rabbit portrayed on the design, which, contrary to the intervener's assertion, plays a minor role in the overall impression conveyed by the design (para. 50). Only Bulgarian consumers with knowledge of English, or any other language in which the word 'cornet' exists and has the same meaning, will understand that that word designates the goods wrapped in packaging in the form of a cone portrayed by the contested design and the earlier mark's goods. However, it has not been established that that word forms part of the basic vocabulary in English or in any other language which will be understood by a large part of the relevant public in Bulgaria (para. 53). Therefore, contrary to the findings of BoA the word 'cornet' is not totally devoid of distinctive character (para. 55). In the signs at issue the words 'bobo', 'ozmo' and 'cornet' are written in very visible bold letters and are of the same width (para. 57). Even though the word 'cornet' does not, of itself, dominate the overall impression conveyed by the signs at issue and is not especially distinctive, it cannot, on account, in particular, of its position in the signs and its size, be regarded as playing a negligible role in the overall impression conveyed by the signs. Accordingly, due account must be taken of it when comparing the signs (para. 59). (ii) Visual comparison: the contested design and the earlier mark are both made up of two words, 'bobo' and 'cornet', and 'ozmo' and 'cornet', respectively. The word 'cornet' is therefore common to both. Moreover, the words 'bobo' and 'ozmo' are of the same length and each contains the letter 'o', which appears twice, once at the end of each word. Therefore, they have considerable similarities (paras 62-63). The contested design and the earlier mark are also different in certain respects (paras 64-67). Nevertheless, the elements which differentiate the signs at issue visually do not outweigh the considerable similarities between those signs that will be perceived by consumers. Therefore, the Board of Appeal erred in taking the view that those signs are visually different (para. 68) (iii) Phonetic comparison: the signs at issue have an average degree of phonetic similarity due to the word 'cornet' and that the contested design and the earlier mark have the same number of words with the same number of syllables and the same number of letters, with the appearance of the letter 'o' in both words 'bobo' and 'ozmo' (paras 72-73). (iv) Conceptual comparison: the part of the relevant public that does not understand the meaning of the common word 'cornet' cannot attribute any particular meaning to the signs at issue. Accordingly, it is not possible to make a conceptual comparison of the signs for this part of the public (para. 76). The representations of a rabbit, other animals and food products in the form of cones, which are present on the contested design but not on the earlier mark cannot introduce conceptual difference between the signs because they will play only a







minor role in the overall impression of the contested design (para. 77). In conclusion, contrary to the position reached by the BoA, the signs at issue are visually highly similar, have an average degree of phonetic similarity and are conceptually similar for the members of the relevant public who understand the meaning of the word 'cornet' (para. 78). **LOC**. There is LOC on the part of the relevant public (para. 81). There is no need to examine the second plea as the first has been upheld (para. 83).

**C-395/16; DOCERAM; DOCERAM GmbH v CeramTec GmbH**; Preliminary ruling of 8 March 2018; EU:C:2018:172; Language of the case: DE. The request has been made in the context of a counterclaim for a declaration of invalidity between DOCERAM GmbH and CeramTec GmbH. Relying on an infringement of its Community designs, DOCERAM brought an action against CeramTec before the Landgericht Düsseldorf (Regional Court, Düsseldorf, Germany), seeking an order for CeramTec to discontinue the infringement of its intellectual property rights. The latter brought a counterclaim for a declaration of invalidity of the contested designs, maintaining that the features of appearance of the products in question were dictated solely by their technical function (para. 12). The Regional Court, Düsseldorf dismissed the action brought by DOCERAM and declared the contested designs to be invalid, since they were excluded from the protection of Article 8(1) CDR (para. 13). DOCERAM appealed against that judgment to the Oberlandesgericht Düsseldorf (Higher Regional Court, Düsseldorf, Germany). According to that court, it is necessary to establish whether the existence of alternative designs of the centring pins leads to the conclusion that the features of appearance of those products are not covered by Article 8(1) CDR, or whether it is also necessary to ascertain whether the technical function was the only factor that dictated those features (para. 14). The EU Courts adopted different criterion for the application of Article 8(1) CDR. According to one approach, the sole criterion is the existence of alternative designs that fulfil the same technical function, which demonstrates that the design is not dictated solely by reason of its technical function within the meaning of that provision (multiplicity of form test). The opposing view is that Article 8(1) CDR is applicable where the various features of appearance of the product are dictated solely by the need to achieve a technical solution and that the aesthetic considerations are entirely irrelevant (causative test) (para. 15). In those circumstances, the Higher Regional Court, Düsseldorf decided to stay the proceedings and refer the following questions to the Court of Justice for a preliminary ruling. **Questions.** (1) Are there features of appearance of a product solely dictated by its technical function within the meaning of Article 8(1) CDR, which excludes protection, even if the design effect is of no significance for the product design, and the (technical) functionality is the sole factor that dictates the design? If the Court answers Question 1 in the affirmative: (2) Which point of view is to be used to assess whether the individual features of appearance of a product have been chosen solely on the basis of considerations of functionality? Is an 'objective observer' required and, if so, how is such an observer defined? (para. 16) **Answer.** Article 8(1) CDR must be interpreted as meaning that in order to determine whether the features of appearance of a product are exclusively dictated by its technical function, it must be established that the technical function is the only factor that determined those features. The existence of alternative designs is not decisive in that regard (para. 32). In order to determine whether the relevant features of appearance of a product are solely dictated by its technical function, the national court must take account of all the objective circumstances relevant to each individual case. In that regard, there is no need to base those findings on the perception of an 'objective observer' (para. 39).

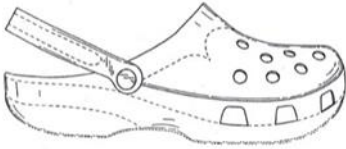

**T-651/16; Footwear; Crocs, Inc v EUIPO**; Judgment of 14 March 2018; EU:T:2018:137;  
 Language of the case: EN

RCD	Earlier design
	

The design above was sought to be registered as an RCD for the product indication *Footwear* for goods in Class 02-04 of the Locarno Classification. After its registration, it was transferred to the RCD proprietor. An application for invalidity was filed pursuant to Article 52 CDR in conjunction with Article 5 CDR. The Invalidity Division (ID) dismissed the application for invalidity insofar as it found that the documents submitted were not sufficient evidence of prior disclosure of the contested design (not dated or poor quality). The invalidity applicant appealed and the Board of Appeal (BoA) upheld the appeal. After accepting the additional evidence submitted before it, it found prior disclosure of the design by exhibition and use in trade, which, therefore, lacked novelty. The RCD proprietor filed an action before the General Court (GC) relying on two pleas in law: (i) infringement of Article 63(2) CDR and (ii) infringement of Article 7 CDR. (i) Regarding the argument that the admission of new disclosure evidence later in the proceedings altered the scope of the application for a declaration of invalidity, the GC found that the contested exhibits cannot be regarded as ‘new’ evidence but rather as additional to the evidence already submitted. They are perfectly relevant to the outcome of the proceedings before the BoA, in order to prove that the clog, to which the contested design had been applied, had been advertised and put on sale. Furthermore, the exhibits were submitted during the appeal before the BoA and the RCD proprietor was able to submit observations prior to the BoA’s decision. Those exhibits also directly originated from its own website and were therefore known to it (para. 36). (ii) The three disclosure events, namely the display of clogs on the applicant’s website, the exhibition of the clogs at the Fort Lauderdale Boat Show and the fact that the clogs were available for sale through a distribution and retail network, occurred before the relevant period started, bearing in mind that even a single disclosure event is sufficient to find that the contested design lacks novelty (paras 50 and 70). Even if they took place outside the EU, at least taken as a whole, the contested design has been ‘exhibited, used in trade or otherwise disclosed’ (para. 52). The website was technically accessible worldwide, and, in addition, it is not apparent from the expert reports that the applicant’s website was not included in the results of a search using the applicant’s name ‘crocs’ (paras 61-62). The BoA relied on the evidence from the RCD proprietor’s website to show that the exhibition at the Fort Lauderdale Boat Show of the clogs and the fact that the clogs were available for sale through a distribution and retail network had actually taken place (para. 64). In any event, the Fort Lauderdale Boat Show is an important international event in the nautical sector and that it is therefore unlikely that EU professionals from the footwear industry could not have become aware of the new clog designed for boating (para. 66). Moreover, the clogs were put on sale in numerous US states, and, given the importance for the EU market of commercial trends on the US market, it could not have gone unnoticed by the circles



specialised in the sector concerned, operating within the EU (para. 67).

**T-756/16; Treillages; Euro Castor Green v EUIPO;** Judgment of 25 April 2018; EU:T:2018:224; Language of the case: FR

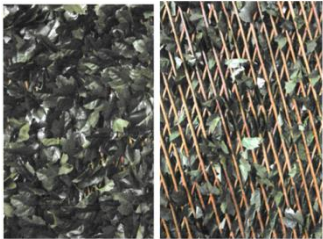
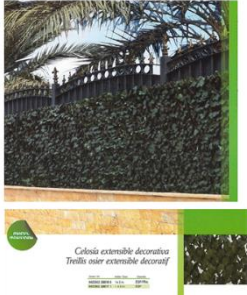
RCD	Earlier design
	

The RCD holder, applicant before the General Court (GC), was granted registration of the design above as an RCD for product indication *latticework screening* in Class 25-02 under the Locarno Classification. An application for invalidity was filed pursuant to Article 25(1)(b) CDR in conjunction with Articles 4 to 9 CDR, relying, inter alia, on the prior disclosure of the earlier design ‘Netlon’. The Invalidity Division (ID) dismissed the application for invalidity, so the invalidity applicant appealed this decision. The Boards of Appeal (BoA) upheld the appeal, annulled the ID’s decision and found that the RCD lacked both novelty and individual character. The RCD holder appealed to the GC relying on four pleas in law: (i) infringement of Articles 5, 7 and 25(1)(b) CDR, (ii) infringement of Articles 5, 6, 7 and 25(1)(b) CDR, (iii) infringement of Article 3(1)(b) CDR, and (iv) infringement of Article 8(1) CDR. The GC dismissed the RCD holder’s appeal. (i) Regarding the first plea in law, the GC concluded that the disclosure of the earlier design was established, within the meaning of Article 7 CDR, in France, on the basis of a catalogue, invoices and exchanges of emails, all documents referring to the same product as identified by a product code (para. 44), and in Spain, on the basis of online publications (para. 45). (ii) In the absence of specific arguments put forward by the RCD holder regarding the identity of the compared designs, the conclusion that the contested RCD lacks novelty is confirmed (para. 62). As a consequence, the second plea relating to a violation of Article 6 CDR (individual character) must be dismissed (paras 66-67). (iii) Both the third and fourth pleas were considered inadmissible by the GC since the BoA neither based its decision on Article 3(1)(b) CDR (para. 70), nor on Article 8(1) CDR (para. 74).

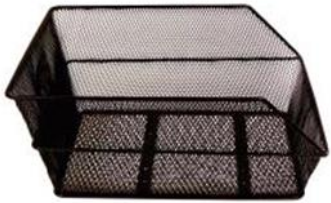
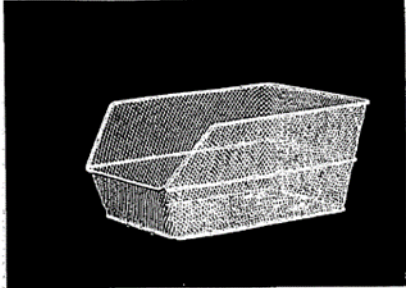

**T-760/16; Fahrradkörbe; Basil BV v EUIPO;** Judgment of 17 May 2018; EU:T:2018:277;  
Language of the case: DE

RCD	Earlier design
	 <p data-bbox="863 745 1190 824"> <b>34.54.50</b> • Hinterer Maschekorb mod. Speedy  <b>39x30x17</b> • Cesto Speedy posteriore in rete            • Back mesh Speedy basket            • Panier postérieur Speedy en filet         </p>

The RCD proprietor registered the design shown above as an RCD with the product indication *baskets for bicycles* in Class 03-01 of the Locarno Classification. An invalidity application was filed pursuant to Article 25(1)(b) CDR in conjunction with Article 52 CDR, relying on the disclosure of an earlier design. The Invalidity Division (ID) upheld the application insofar as it found that the contested design had no individual character. The RCD proprietor appealed and the Board of Appeal (BoA) dismissed the appeal and confirmed the ID’s decision. The RCD proprietor appealed to the General Court (GC) relying on three pleas in law: (i) infringement of Article 52(3) CDR, (ii) infringement of Article 7 CDR, and (iii) infringement of Article 6 CDR. (i) The application is admissible for the following reasons: (a) according to its wording, Article 52(3) CDR exclusively applies to Community design courts and not to decisions of the EUIPO (paras 19-20); (b) the fact that the invalidity applicant is closely associated with a former applicant (client relationship) and both applications are closely linked does not amount to *res judicata* (paras 22-24); (c) Article 52(3) CDR cannot be applied in the event of a prior decision by the EUIPO (paras 28-30); furthermore, given the level of control regarding the validity of the designs prior to registration, the invalidity proceedings have a different position in the CDR system than the one they occupy in the EUTMR system (substantial control) (paras 29-34). (ii) The earlier design, specifically the bicycle basket designated by the term ‘Speedy’, is pictured with the item number 34.54.50 in an original submitted copy of the applicant’s catalogue. The invalidity applicant submitted numerous invoices that it had issued to various companies in Italy. These invoices, dated between 2000 and 2002, show the sale of a ‘Speedy’ bicycle basket with the item number 34.54.50 (para. 43). The same bicycle basket is pictured in four catalogues from other companies between 2001 and 2002, and it also appears in an image of a stand at the Cologne trade fair (para. 44). Therefore, the disclosure of the earlier design was duly proved before the filing date of the application for registration (para. 45). (iii) The contested RCD lacks any individual character given in particular that (a) while the designer’s degree of freedom in the case of bicycle baskets is limited by technical specifications (bicycle baskets must be fastened to the bicycle and be able to hold objects without them falling out while cycling), it was possible to choose between a wide variety of colours, materials and shapes for the basket; and (b) the opposing designs coincide in various features (paras 80-85).

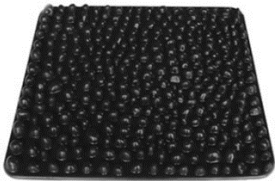
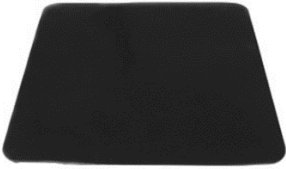
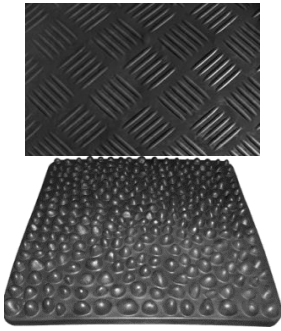

**T-227/16; Foot mat; Haverkamp IP GmbH v EUIPO; Judgment of 21 June 2018; EU:T:2018:370; Language of the case: DE**

RCD	Earlier design
<p>1.1</p>  <p>1.2</p> 	

The RCD proprietor registered the design above as an RCD with the product indication *foot mat* in Class 6-11 of the Locarno Classification. An invalidity application was filed by the intervener pursuant to Article 25 CDR in conjunction with Article 106(f) CDR. It was based on the intervener's earlier Swiss registered design for *health mats* in the same class of the Locarno Classification. The Invalidation Division (ID) upheld the invalidity application as the design lacked individual character. The Board of Appeal (BoA) dismissed the RCD proprietor's appeal. The RCD proprietor appealed to the General Court (GC) relying on one sole plea in law: infringement of Article 6(1)(b) CDR on individual character. **Disclosure to the public of an earlier design.** An invalidity applicant is not confined to specific, predetermined means of evidence to prove disclosure to the public of an earlier design, but is free to choose the form of evidence to submit. The invalidity applicant is not confined to submitting documents in one given language. Consequently, the Office examines all the elements submitted to assess whether they constitute evidence of disclosure (paras 26-28). **Informed user.** The informed user regularly purchases foot mats and uses them for their purpose, which is not confined to massage mats, but includes shower mats or car mats for instance, regardless of the filed description. Moreover, the Office is not bound by the coinciding declarations of the parties on the use of the goods (paras 47-50). **Saturation of the state of art.** Saturation of the state of the art in a given sector cannot be presumed, it must be sufficiently proved by the party alleging it. In that respect, six prior design registrations are insufficient to establish saturation of the state of the art (para. 66). **Global impression of conflicting designs.** The barely perceptible differences on the upper faces of the mats and the negligible differences on their lower faces do not alter the fact that their global impression is the same. This is particularly true where the conflicting designs possess common characteristics that concern elements that a designer can freely modify (paras 72-78).

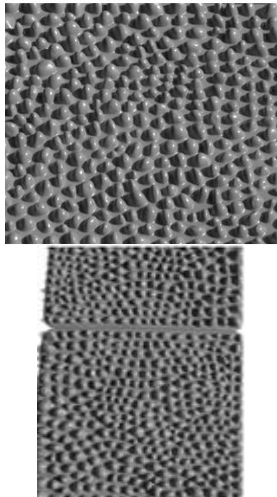
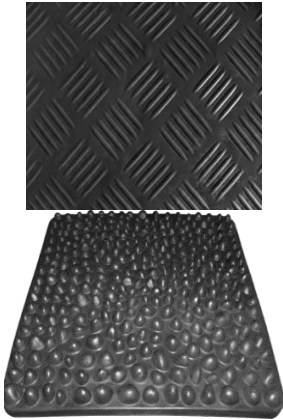

**T-228/16; Pebble beach surface pattern; Haverkamp IP GmbH v EUIPO**; Judgment of 21 June 2018; EU:T:2018:369; Language of the case: DE

RCD	Earlier design
<p>1.1</p> 	

The RCD proprietor registered the design above as an RCD with the product indication *pebble beach surface pattern* in Class 32-00 of the Locarno Classification. An invalidity application was filed by the intervener pursuant to Article 25 CDR in conjunction with Article 106(f) CDR. The application was based on the intervener’s earlier Swiss registered design for *health mats* in Class 6-11 of the Locarno Classification. The Invalidity Division (ID) upheld the invalidity application as the contested design lacked novelty. The Board of Appeal (BoA) dismissed the appeal on the grounds that the design was not new and lacked individual character. The RCD proprietor appealed to the General Court (GC) relying on two pleas in law: (i) lack of novelty and (ii) lack of individual character. Since the GC found that the RCD was not new, the court did not find it necessary to examine the second plea.

**Disclosure to the public of the earlier design.** An invalidity applicant is not confined to specific, predetermined means of evidence to prove disclosure to the public of an earlier design, but is free to choose the form of evidence. The invalidity applicant is not confined to submitting documents in one given language. Consequently, the Office examines all the elements submitted to assess whether they constitute evidence of disclosure (paras 25-27).

**Identity of the designs.** The comparison must be based on the features disclosed by the contested design; additional features of the earlier design are irrelevant (para. 38). When assessing novelty, it is irrelevant that the earlier design constitutes a health mat whereas the contested design relates to a surface pattern which may be applied to any type of product (para. 42). The conflicting designs are identical. Possible differences in the form, height and size of the pebbles are immaterial. Moreover, any height difference may result from different viewing angles (paras 45-46).



**T-367/17; Electrically operated lifting column, in particular for tables; Linak A/S v EUIPO;** Judgment of 18 October 2018; EU:T:2018:694; Language of the case: EN

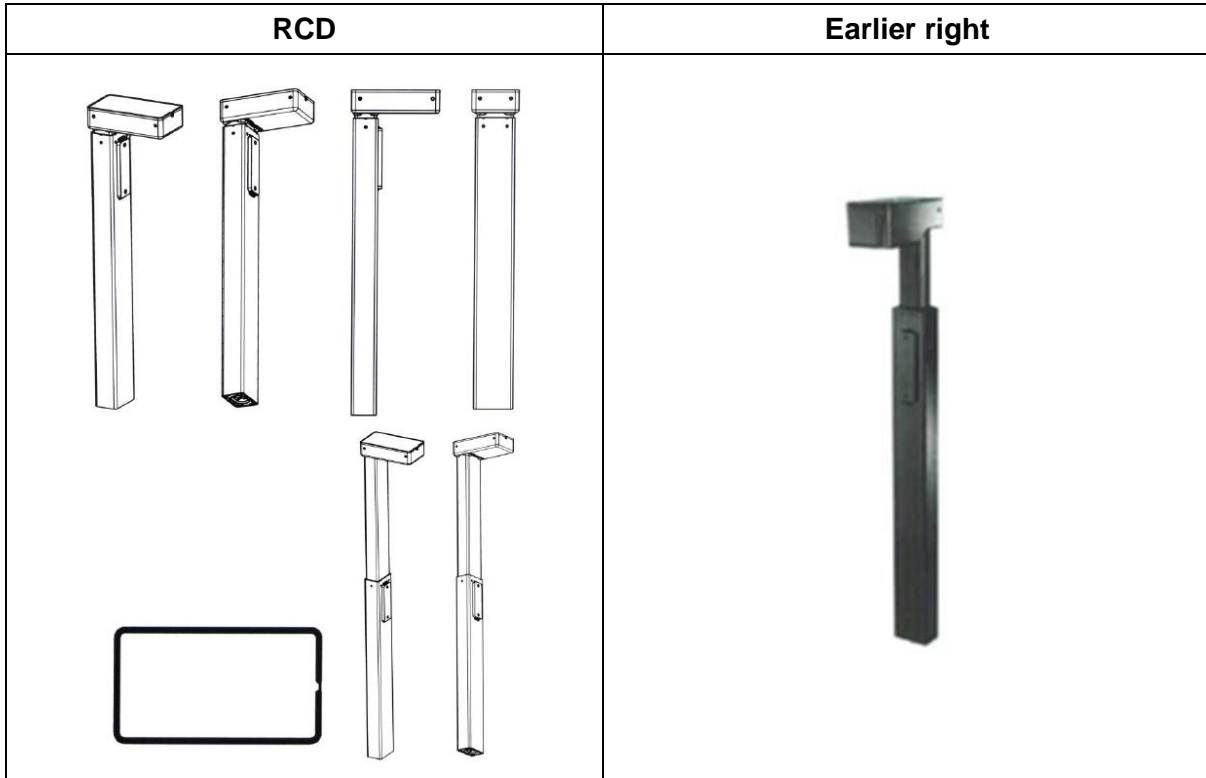

The applicant applied for registration of the Community design (RCD) above for goods in Classes 06-06 and 15-99. An application for a declaration of invalidity of the contested design was filed pursuant to Article 25(1)(b) CDR. The Invalidity Division (ID) upheld the application for a declaration of invalidity on the grounds that the design was not new within the meaning of Article 5 CDR. The Board of Appeal (BoA) confirmed the ID’s decision, but based its argumentation on Article 25(1)(b) CDR in conjunction with Article 6 CDR and declared that the contested RCD lacked individual character. The applicant filed an action with the General Court (GC), relying on a single plea in law: infringement of Article 6 CDR.

**Nature of the goods and the industrial sector concerned.** The court confirmed the BoA’s findings as regards the common features of the designs compared and the differences between them (paras 21, 23). The court also confirmed the BoA’s conclusion that the sector in question was the furniture industry (paras 22, 23). **The informed user.** The court agreed that the qualifier ‘informed’ suggests in addition that, without being a designer or a technical expert, the user is familiar with the various designs that exist in the sector concerned, possesses a certain degree of knowledge with regard to the features that those designs normally include and, as a result of his or her interest in the products concerned, shows a relatively high degree of attention when using them (para. 26). Therefore, the concept of the ‘informed user’ may be understood as referring, not to a user of average attention, but to a particularly observant one, either because of his or her personal experience or his or her extensive knowledge of the sector in question (para. 27). The BoA had correctly described the informed user as a purchaser of lifting columns (para. 29). Further, it stated that the BoA’s definition also encompassed sellers and distributors of electrically operated lifting columns, as well as users who purchased them for their own needs. Therefore, the informed user must be held to be both the end consumer and commercial seller (para. 30). The overall impression produced by the contested design



in relation to one of the two groups of informed users was the impression produced on an expert with a high level of attention (para. 32). Therefore, the BoA’s assessment concerning the definition of the informed user was correct and should be confirmed (para. 33). **Assessment of individual character.** The BoA had been right in finding that the appearance and structure of the designs were the same and that the only differences between them were in the details of the finish and the thickness of the housing on top of the telescopic arm, the diameter and shape of the telescopic arm, and the colour of the designs (para. 37). Therefore, the designs were too similar to be able to produce a different overall impression on the informed user. The designs therefore did not differ from one another before or after their incorporation in a piece of furniture (para. 42). The BoA had correctly stated that, even when the designs were looked at from all possible angles, the overall impression remained unchanged given the coincidence of the main features of the designs (para. 44). The court also confirmed the BoA’s conclusion that, when the contested design was incorporated in a table, it did not display differences that were sufficiently marked for it to produce a different overall impression on the informed user and to be found to have individual character (para. 46). The applicant’s single plea in law therefore had to be rejected (para. 47).

**T-368/17; Electrically operated lifting column, in particular for tables; Linak A/S v EUIPO**; Judgment of 18 October 2018; EU:T:2018:695; Language of the case: EN

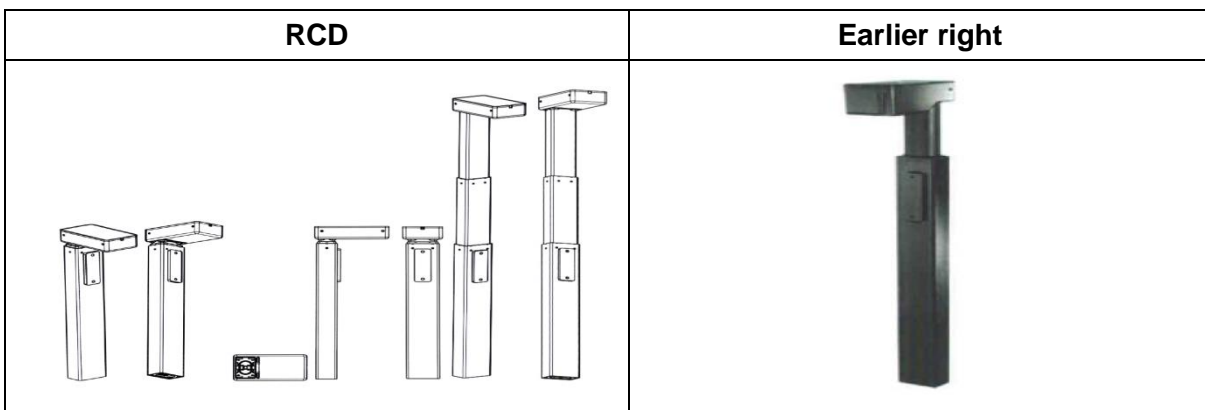

The applicant applied for registration of the Community design (RCD) above for goods in Classes 06-06 and 15-99. An application for a declaration of invalidity of the contested design was filed pursuant to Article 25(1)(b) CDR. The Invalidity Division (ID) upheld the application for a declaration of invalidity on the grounds that the design was not new within the meaning of Article 5 CDR. The Board of Appeal (BoA) confirmed the ID’s decision, but based its argumentation on Article 25(1)(b) CDR in conjunction with Article 6 CDR and declared that the contested RCD lacked individual character. The applicant filed an action with the General Court (GC), relying on a single plea in law: infringement of Article 6 CDR. **Nature of the goods and the industrial sector concerned.** The court confirmed the BoA’s findings as regards the common features of the designs compared (inverted L-shape, a smooth surface, a telescopic arm consisting of two telescoping tubes with rounded edges, a smaller rectangular plaque positioned on the lower tube of the telescopic arm, the housing on top of the telescopic arm and the rectangular shape of the housing) and the differences between them (differences in housings, the telescopic arms and the colour of the designs) (paras 21, 23). The court also confirmed the BoA’s conclusion that the sector in question was the furniture industry (paras 22, 23). **The informed user.** The court agreed that the qualifier ‘informed’ suggests in addition that, without being a designer or a technical expert, the user is familiar with the various designs that exist in the sector concerned,





possesses a certain degree of knowledge with regard to the features that those designs normally include and, as a result of his or her interest in the products concerned, shows a relatively high degree of attention when using them (para. 26). Therefore, the concept of the ‘informed user’ may be understood as referring, not to a user of average attention, but to a particularly observant one, either because of his or her personal experience or his or her extensive knowledge of the sector in question (para. 27). The BoA had correctly described the informed user as a purchaser of lifting columns (para. 29). Further, it stated that the BoA’s definition also encompassed sellers and distributors of electrically operated lifting columns, as well as users who purchased them for their own needs. Therefore, the informed user must be held to be both the end consumer and commercial seller (para. 30). The overall impression produced by the contested design in relation to one of the two groups of informed users was the impression produced on an expert with a high level of attention (para. 32). Therefore, the BoA’s assessment concerning the definition of the informed user was correct and should be confirmed (para. 33). **Assessment of individual character.** The BoA had been right in finding that the appearance and structure of the designs were the same and that the only differences between them were in the details of the finish and the thickness of the housing on top of the telescopic arm, the diameter and shape of the telescopic arm, and the colour of the designs (para. 37). Therefore, the designs were too similar to be able to produce a different overall impression on the informed user. The designs therefore did not differ from one another before or after their incorporation in a piece of furniture (para. 42). The BoA had correctly stated that, even when the designs were looked at from all possible angles, the overall impression remained unchanged given the coincidence of the main features of the designs (para. 44). The court also confirmed the BoA’s conclusion that, when the contested design was incorporated in a table, it did not display differences that were sufficiently marked for it to produce a different overall impression on the informed user and to be found to have individual character (para. 46). The applicant’s single plea in law therefore had to be rejected (para. 47).



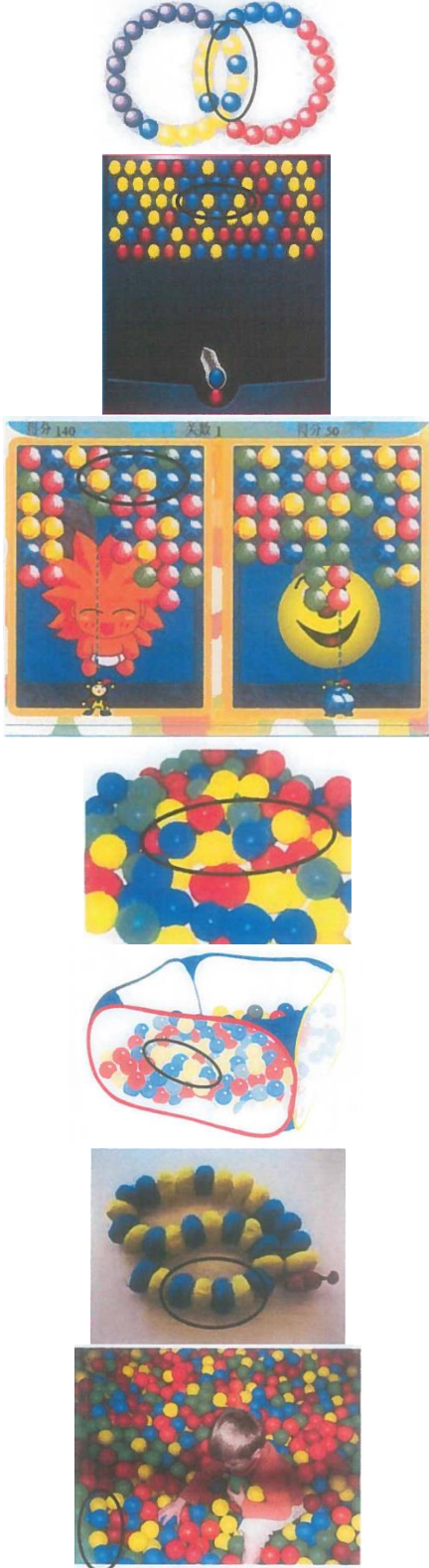

**T-296/17; SPÜLUNGEN FÜR W.C. (WASSER-);** *Buck-Chemie GmbH v EUIPO*; Judgment of 22 November 2018; EU:T:2018:823; Language of the case: DE

RCD	Earlier designs
	



The intervener obtained the registration of the Community design (RCD) above, intended to be applied to *toilet flushes* in Class 09-05 of the Locarno Classification. A declaration of invalidity of the RCD has been filed pursuant to Article 25(1)(b) CDR. The Invalidity Division (ID) rejected the application. The applicant filed an appeal against the ID’s decision and the Board of Appeal (BoA) dismissed the appeal finding that the earlier designs relied on did not preclude the novelty and individual character of the RCD within the meaning of Articles 4 to 6 CDR. The applicant filed an action before the General Court (GC), relying on three pleas in law: (i) infringement of Article 63 CDR read in conjunction with Article 25(1)(a) and Article 3(a) CDR, (ii) infringement of Article 62 CDR read in conjunction with Article 25(1)(b) CDR and Articles 4 and 5 CDR and (iii) infringement of Article 25(1)(b) CDR and Articles 4 and 6 CDR. (i) The first plea is manifestly unfounded insofar as it is clear from the wording of Article 63(1) CDR that, in a declaration of invalidity, the examination of the facts is limited to the pleas in law relied on and the applications submitted by the parties. The applicant itself admits that it did not invoke the ground for invalidity referred to in Article 25(1)(a) CDR in the form of its application for a declaration of invalidity (paras 19-20). (ii) The BoA was entitled to conclude that the RCD was new due to the fact that it was found to be individual (para. 31). (iii) The first view of the RCD shows that the four balls are aligned side by side in a row. The BoA was correct to define the product concerned as a detergent ‘block’ and not as four isolated products (para. 46). Since this type of product naturally imposes constraints in terms of its material, the BoA was right in finding that the degree of freedom of the designer was limited (para. 48). Regarding the ball pools invoked as earlier designs, it is well known that they are characterised by a random and unpredictable mixture of balls. The applicant’s assertion that said representations are ‘static’ and show a specific order of balls is manifestly unfounded (para. 50). Regarding the puzzle called ‘Hungarian rings’ (which is the first earlier design above), the succession of blue and yellow balls are only visible in the part of the design highlighted by an oval, and this part is not independent in nature and cannot be separated from the overall impression produced by the product (para. 52). The extract from the instructions of the game differs considerably from the contested design, which represents a linear arrangement of four balls, alternately blue and yellow (para. 53).

**T-651/17; Spray guns for paint; Sata GmbH & Co. KG v EUIPO**; Judgment of 29 November 2018; EU:T:2018:855; Language of the case: EN

RCD	Earlier design
	

The RCD proprietor registered the design above as an RCD for goods in Class 08.05 of the Locarno Classification. An invalidity application was filed pursuant to Article 25(1)(b) CDR in conjunction with Articles 4 to 9 CDR, relying, inter alia, on the earlier design above. The



Invalidity Division (ID) upheld the invalidity application. It found that the contested design lacked individual character. The RCD proprietor filed an appeal. The Board of Appeal (BoA) dismissed the appeal, insofar as it found that the contested design lacked individual character with regard to the earlier design, since the differences between them were insufficient to produce a different overall impression on the informed user. The RCD proprietor filed an action with the General Court (GC), relying on two pleas in law: (i) infringement of Article 25(1)(b) CDR in conjunction with Article 6 CDR, and (ii) infringement of Articles 62 and 64 CDR. **The designer's degree of freedom.** Paint spray guns follow the same basic concept: they share the same basic shape of a gun and the components necessary for their function of painting, namely the handle, the trigger and the muzzle, as well as the devices for adjustment of paint flow and pressurised air. However, it is perfectly possible that the size, the shape, the weight, the structure and the arrangement of the components of paint spray guns will vary from one design to another (para. 34). There is a considerable degree of design freedom for paint spray guns with regard to their appearance and specific arrangement (para. 35). **Individual character.** It does not automatically follow from the technical function of the components of a paint spray gun that all these components must have identical features of appearance. The appearance of all these components, namely the gun body, the spray head, the trigger and the handle might vary in shape and proportions. The BoA was right to find that, although the informed user will not give great weight to the presence of these components on account of their technical function, there is no reason to ignore their specific appearance in the overall impression (para. 42). The use of the notion of 'déjà vu' is in keeping with settled case-law in this area, in particular, on the notion of the individual character of a design (para. 48). **Possible saturation of the state of the art.** The differences between the designs would not tend to give rise to a different overall impression for an informed user even in the event of saturation of the state of the art. Although the BoA did not use the expression 'saturation of the state of the art', it did address the relevant argument (para. 55). In addition, the RCD proprietor merely repeated before the BoA established case-law, and mentioned in that context a possible impact of a saturation of the state of the art. However, the RCD proprietor did not submit sufficient evidence to establish the existence of a saturation of the state of the art in the field of paint spray guns, or that the saturation of the state of the art might affect the informed user's perception (para. 56). The RCD proprietor did not submit other designs to substantiate its claims relating to the saturation of the state of the art (para. 57).



**C. Other issues**

♦ [T-166/15](#); **Sacs pour ordinateurs portables**; *Claus Gramberg v EUIPO*; Judgment of 27 February 2018; EU:T:2018:100; Language of the case: DE

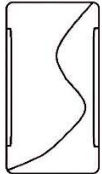
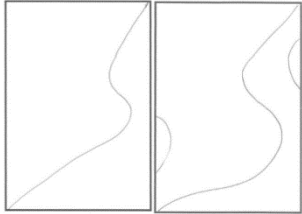
RCD	French designs on which priority claimed was based
	

The Office registered a design with a priority date of 30 June 2011, intended to be used for covers for telephones, laptop bags, cases (for mobile phones), cases for computers, and cases for mobile phones in Class 03.01. The applicant submitted an application for a declaration of invalidity of the contested design for lack of novelty, because it sells, under the brand ‘mumbi’, accessories for mobile phones, including cases for these devices, mainly on the online sales portal ‘amazon.de’, under the seller name of ‘HandyNow’. The applicant argued that the contested design had been disclosed before the priority date and it submitted proof in this regard (invoices, screenshots/printouts of websites (Amazon, eBay), declarations). The Cancellation Division (CD) considered valid the evidence provided for a prior disclosure and declared the invalidity of the design because of the lack of individual character. The RCD holder appealed against the CD’s decision. The applicant provided three new pieces of evidence. The Board of Appeal (BoA) annulled the CD’s decision and rejected the declaration of invalidity because it considered that the evidence was insufficient in order to prove the disclosure of the design. The applicant filed an action before the General Court (GC) relying on three pleas in law: (i) infringement of Article 5(1)(b) and Article 7(1) CDR, (ii) infringement of an essential procedural requirement, (iii) the BoA did not take into account the fact that the RCD holder could not validly claim the priority of the contested design. **On the findings of the probative value of the ‘amazon.de’ screenshots.** The applicant refers to a specific reference number corresponding to a single offer contained in the annex (D4a and D4b), namely ASIN B0058COLXM. This reference appears before the date of the availability of the offer on the online shop ‘amazon.de’ and it is provided by the ‘amazon’ page when the product is offered for the first time in the Amazon catalogue (paras 44 and 45). The ASIN number assigned to a single offer necessarily reflects the reliability of the annexes and demonstrates the disclosure of the contested design before 30 June 2011. Therefore, the BoA was wrong when it disregarded these annexes but was right for annex D2 as it did not contain this ASIN number (para. 55). Annexes D3 and D5 corroborate the disclosure of the contested design as of 26 May 2011 as the invoice sent by the applicant to a customer (D3) contains a description of the case similar to that on the website ‘amazon.de’ (‘Silikon Case mumbi HTC Desire HD Silicon Tasche Hülle — DesireHD Schutzhülle’). Moreover, it has the same price (EUR 6.99) as the product bearing the number ASIN B0052TD5OM and been available on this site since 26 May 2011. The order to buy this case is dated 27 May 2011 (paras 61 and 62). The GC found that the photograph of the case (D5) reveals the shape, similar to the contested design, and the file refers to the author, ‘HandyNow’, on 26 May 2011, and to the applicant’s mark, ‘mumbi’, which is also included in the description on the website ‘amazon.de’ and mentioned in annexes D2, D4a and D4b (paras 65-66).



The BoA made a wrong assessment of the probative value of annex D4b as it has common characteristics compared to the contested design (paras 69-72). Regarding annex D11, the EUIPO argued that the applicant’s explanations of the doubts expressed by the RCD holder are irrelevant, since they are given for the first time before the GC (para. 76). The BoA made a wrong assessment of D11 as the quality of the image is good and has similar characteristics compared to the contested design (paras 82-83). The images contained in D7 are clear and they were sufficiently similar to those of the contested design (para. 87). **On the probative value of the emails including the Alibaba.com newsletter.** The document in annex D7 does not consist solely of an email, it also includes a newsletter sent to the applicant by the online sales company ‘Alibaba.com’ (para. 93). The GC therefore considers that the errors of assessment of the evidence made by the BoA led to the annulment of the contested decision (para. 95). Since one ground is sufficient, there is no need to examine the two other pleas in law (para. 96).

**T-672/17; Cot bumpers; Mamas and Papas Ltd v EUIPO;** Judgment of 23 October 2018; EU:T:2018:707; Language of the case: EN

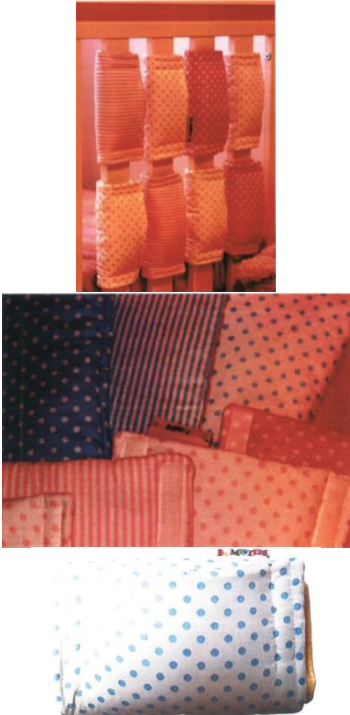
RCD	Earlier designs
	

The registered Community design (RCD) holder registered the design above for *cot bumpers* in Class 06-06 of the Locarno Classification. An invalidity application based on the earlier designs above was filed pursuant to Article 25(1)(b) CDR, asserting that the RCD lacked novelty and individual character and differed from the previous state of the art only in features that were solely dictated by its technical function. The Invalidity Division (ID) dismissed the application. The applicant appealed against the ID’s decision. The Board of Appeal (BoA) dismissed the appeal, on the grounds that the applicant had failed to demonstrate by solid and objective evidence the disclosure of an earlier design and, in any event, that the contested design produced a different overall impression on the informed user from that produced by the earlier design. The applicant filed an action with the General



Court (GC), relying on four pleas in law: (i) infringement of Article 7(1) CDR, (ii) infringement of Article 3(b) and (c) CDR, (iii) infringement of Article 6 CDR and (iv) infringement of Article 8(1) CDR. **Examination of the facts constituting disclosure.** The question relating to the disclosure of an earlier design is a key issue, the resolution of which is necessary at the outset for the correct application of Articles 5 and 6 CDR. The Office may therefore rule on the question even if it was not raised by the parties (paras 30-31). Article 63(1) CDR precludes the Office from taking into consideration facts that were not put forward by the parties (with the exception of well-known facts), but does not prevent it, on the basis of its assessment of the facts put forward by one of the parties, from arriving at a finding different from that desired by the party in question (para. 35). Disclosure within the meaning of Article 7(1) CDR does not, as such, constitute a fact within the meaning of Article 63(1) CDR but is rather the result of a factual assessment (para. 36). Accordingly, the Office is entitled to arrive at a finding different from that sought by the parties, provided the finding is based on an assessment of the facts and evidence presented by the parties (para. 37). This is so even if the event of disclosure was not challenged by the ID (para. 38). Indeed, by virtue of the devolutive effect of appeal proceedings, the BoA must re-examine the initial application in full and take into account evidence produced in due time (para. 39). **Erroneous assessment of the evidence.** The BoA found that the evidence submitted by the applicant did not establish that the earlier design had been disclosed before the date of filing of the application for registration of the contested design (para. 51). The BoA found that, in the absence of additional information, disclosure could not be proved solely on the basis of the documents submitted by the applicant. The fact that the RCD holder did not call into question the disclosure of the earlier design could not discharge the applicant from its obligation to adduce proof or compensate for the lack of evidence of the disclosure (para. 52). The evidential value of the information contained in the draft particulars of infringement proceedings by the RCD holder against the applicant is uncertain (para. 58). The information, insofar as it is not derived from an independent source, but from the RCD holder, cannot suffice in itself to prove the disclosure of the earlier design (para. 59). The fact that the RCD holder has not challenged the disclosure of the product cannot strengthen the evidential value of the documents produced by the applicant or compensate for its lack of evidence (para. 60). The BoA was right to find that the evidence submitted by the applicant did not prove the disclosure of the earlier design (para. 61). The action must therefore be dismissed as unfounded, without it being necessary to consider the other pleas in the application (para. 63).



## VII. ENFORCEMENT

**C-642/16**; Junek Europ-Vertrieb GmbH *Junek Europ-Vertrieb GmbH v Lohmann & Rauscher International GmbH & Co. KG*; Preliminary ruling of 17 May 2018; EU:C:2018:322; Language of the case: DE

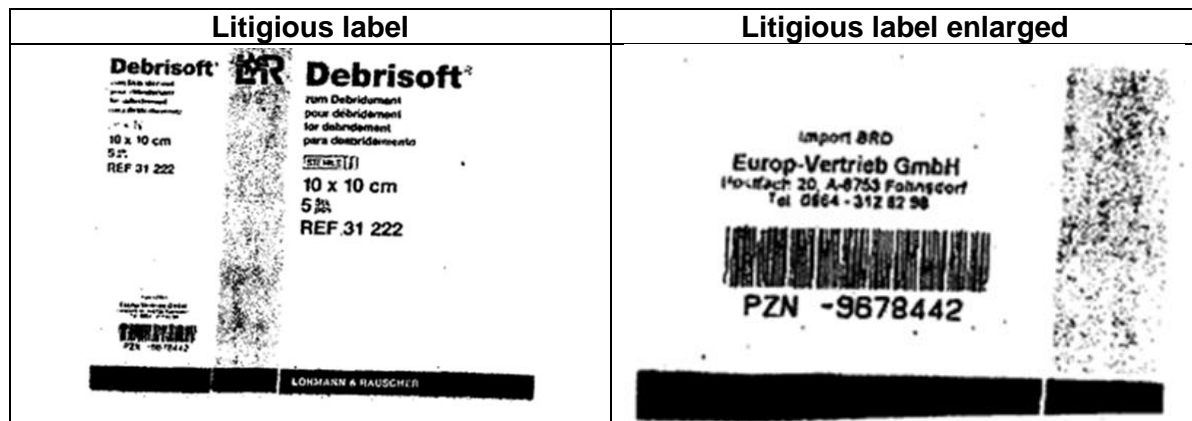

The request for a preliminary ruling was made in proceedings between Junek Europ-Vertrieb GmbH and Lohmann & Rauscher. The latter requested to prohibit Junek Europ-Vertrieb GmbH from using, in the course of trade in Germany, without the consent of Lohmann & Rauscher, medical devices for debridement dressings manufactured by Lohmann & Rauscher in Germany and exported to Austria. Lohmann & Rauscher is the proprietor of the EU word mark **Debrisoft** for medical dressings. Junek Europ-Vertrieb GmbH markets these dressings in Germany via parallel imports from Austria. Junek Europ-Vertrieb GmbH added a litigious label to the packaging of the products, illustrated above. Lohmann & Rauscher lodged an action before the Landgericht Düsseldorf (Regional Court, Düsseldorf, Germany) for an order that Junek Europ-Vertrieb GmbH cannot market the goods without its consent, arguing that Junek Europ-Vertrieb GmbH had infringed its Debrisoft EUTM. The Regional Court, Düsseldorf, upheld the action, and the appeal before the Oberlandesgericht Düsseldorf (Higher Regional Court, Düsseldorf, Germany), brought by Junek Europ-Vertrieb GmbH, was dismissed. Junek Europ-Vertrieb GmbH lodged an appeal on a point of law before the Bundesgerichtshof (Federal Court of Justice, Germany) against the decision. The Federal Court is uncertain whether the principles developed by the court concerning the parallel import of pharmaceuticals, according to which prior notice and the supply of a packaging specimen at the request of the trade mark proprietor are conditions for exhaustion of the rights, are also intended to apply to the parallel import of medical devices. **Exhaustion of trade mark rights. Parallel imports question.** Should Article 15(2) EUTMR be interpreted as meaning that the proprietor of a trade mark may oppose further commercialisation by a parallel importer of a medical device in its original internal and external packaging when an additional label, such as that at issue in the main proceedings, has been added by the importer? **Answer.** Article 15(2) EUTMR must be interpreted as meaning that the proprietor of a trade mark cannot oppose further commercialisation by a parallel importer of a medical device in its original internal and external packaging where an additional label, such as that at issue in the main proceedings, has been added by the importer. Further, the label's content, function, size, presentation and placement cannot risk the guarantee of origin of the medical device bearing the mark. Given that the packaging of the medical device has not been modified and the original presentation of the packaging has not been affected, other than by the attachment of a small label which does not conceal the mark, nor designate the parallel importer as





responsible for marketing it by setting out its details, a barcode and a central pharmacological number, it cannot be held that the attachment of the label constitutes repackaging (para. 35). Consequently, it cannot be held that the attachment of this label affects the specific purpose of the mark to guarantee the origin of the product that it identifies (para. 36).

**C-129/17; Mitsubishi Shoji Kaisha and Mitsubishi Caterpillar Forklift Europe; Mitsubishi Shoji Kaisha Ltd, Mitsubishi Caterpillar Forklift Europe BV v Duma Forklifts NV, G.S. International BVBA**; Preliminary ruling of 25 July 2018; EU:C:2018:594; Language of the case: EN. Mitsubishi is the proprietor of the EU word and figurative Mitsubishi mark and the Benelux figurative Mitsubishi mark. Mitsubishi Caterpillar Forklift Europe (MCFE) is exclusively authorised to manufacture and sell forklift trucks supplied under the Mitsubishi mark in the EEA market. Duma and GSI made parallel imports into the EEA of forklift trucks bearing the Mitsubishi marks, without the consent of the proprietors of those marks. They acquire the forklift trucks that they bring into EEA territory (placing them under a customs warehousing procedure) from a company within the Mitsubishi group outside the EEA. They then remove all the signs identical to the Mitsubishi marks from those goods, replacing the identification plates and serial numbers with their own signs. They import these goods and then market them both within and outside the EEA. Mitsubishi and MCFE applied to the *Rechtbank van koophandel te Brussel* (Commercial Court, Brussels, Belgium) seeking, in particular, that the court order the cessation of these activities. Their applications were rejected, so they appealed to the *Hof van beroep te Brussel* (Court of Appeal, Brussels, Belgium), before which they sought the prohibition of both the parallel trade in forklift trucks bearing the Mitsubishi mark and the importation and marketing of forklift trucks on which signs identical to those marks have been removed and new signs affixed. As regards the parallel import into the EEA of forklift trucks bearing the Mitsubishi mark, the referring court held that that was a breach of the law on trade marks and upheld the applications. With regard to the importation and marketing in the EEA of Mitsubishi forklift trucks originating in countries that are not members of the EEA on which the signs identical to the Mitsubishi marks were removed and new signs affixed, it observed that the Court of Justice of the European Union (CJEU) had not yet ruled on the question of whether such actions constituted a use that the proprietor of the mark could prohibit. **Questions referred to the CJEU.** The referring court asked, in essence, whether Article 5 Directive 2008/95/EC and Article 9 EUTMR must be interpreted as meaning that the proprietor of a mark may oppose a third party removing all the signs identical to that mark and affixing other signs, without its consent, on products placed in the customs warehouse with a view to importing them or trading them in the EEA where they have never yet been marketed (para. 28). **Findings of the CJEU.** (i) The removal of signs identical to the mark prevents the goods covered from bearing that mark the first time that they are placed on the market in the EEA. Therefore, it deprives the proprietor of that trade mark of the essential right to control the initial marketing in the EEA of those goods (para. 42). (ii) The removal of the signs identical to the mark and the affixing of new signs on the goods with a view to their first appearance on the market in the EEA adversely affects the functions of the mark, since the relevant consumers continue to recognise them as Mitsubishi forklift trucks (paras 43-45). Moreover, such actions preclude the trade mark proprietor from being able to retain customers by virtue of the quality of its goods, and affect the functions of investment and advertising of the mark. The fact that the trade mark proprietor's goods are placed on the market before he or she has placed them on that market bearing their trade mark, is likely to substantially impede the use of that mark, by the proprietor, in order to acquire a reputation. By putting the goods on the EEA market first, they also deprive the proprietor of the possibility of obtaining the economic value of the product bearing that mark and, therefore, of its investment (para. 46). (iii) Under these circumstances, the removal of the signs identical to



the mark and the affixing of new signs on the goods by a third party, without the consent of the proprietor, with a view to importing into or placing those goods on the market in the EEA and with the aim of circumventing the proprietor's right to prohibit the importation of those goods bearing its mark, is contrary to the objective of ensuring undistorted competition (para. 47). (iv) These actions involve active conduct on the part of the third party and are carried out in the exercise of a commercial activity for economic advantage (para. 48). (v) Therefore, Article 5 Directive 2008/95/EC and Article 9 EUTMR must be interpreted as meaning that the proprietor of a mark is entitled to oppose a third party, without its consent, removing all the signs identical to that mark and affixing other signs on the products placed in the customs warehouse with a view to importing them or trading them in the EEA where they have never yet been marketed (para. 52).

**C-521/17; Coöperatieve Vereniging SNB-REACT U.A; *Coöperatieve Vereniging SNB-REACT U.A. v Deepak Mehta***; Preliminary ruling of 7 August 2018; EU:C:2018:639; Language of the case: ET. The request for a preliminary ruling was made during the course of proceedings between Coöperatieve Vereniging SNB-REACT U.A. and Deepak Mehta over the latter's alleged infringement of the intellectual property rights of 10 trade mark proprietors. SNB-REACT, a body established in the Netherlands for the collective representation of trade mark proprietors, brought proceedings before the Harju Maakohus (Court of First Instance, Harju, Estonia) against Mr Mehta, seeking an injunction terminating the infringement of the rights of 10 of its members and seeking damages for the loss caused by Mr Mehta. In support of that application, SNB-REACT submitted that Mr Mehta had registered internet domain names which were unlawfully using signs identical to trade marks owned by its members, together with websites unlawfully offering goods for sale bearing such signs. Furthermore, SNB-REACT argued that Mr Mehta is the owner of IP addresses corresponding to those domain names and websites. Lastly, it maintained that Mr Mehta's was liable for the unlawful use of the signs at issue by those domain names and websites which, it claimed, had been brought to his attention on several occasions. Mr Mehta claimed in his defence that he neither registered the domain names and websites challenged by SNB-REACT, nor used in any way signs identical to the trade marks of the members of SNB-REACT. What Mr Mehta did acknowledge was his ownership of 38 000 IP (Internet Protocol) addresses that he had rented to two companies, which meant that he was to be viewed solely as offering a service providing access to an electronic communication network, together with an information transmission service. The Harju Maakohus (Court of First Instance, Harju) dismissed the action brought by SNB-REACT, ruling, firstly, that the latter had failed to show that it had standing to bring an action in its own name seeking to enforce the rights of its members and to recover compensation for losses caused by the infringement of those rights. Secondly, it ruled that Mr Mehta's liability could not be established as a result of the unlawful activity of persons operating certain domain names and websites, since although Mr Mehta was the owner of the IP addresses linked to the internet domain names unlawfully using signs identical to the trade marks owned by the members of that body, and to the websites unlawfully selling goods bearing such signs, he was neither the owner of those domain names and websites, nor had he himself unlawfully used the signs at issue. In its appeal before the Tallinna Ringkonnakohus (Court of Appeal, Tallinn, Estonia), SNB-REACT submitted, firstly, that it is possible to interpret Article 60(2) of the Estonian Law on trade marks as meaning that a collective representation body has standing to bring, in its own name, an action to defend the rights and interests of its members. Secondly, it submitted that the court of first instance erred in excluding all liability on the part of Mr Mehta for the services that he provided to persons operating domain names and websites in the context of online sales of counterfeit goods. It further submitted that the limitation of liability set out in Article 8(1) of the Estonian Law on information society services applies in fact to service providers who act only as neutral



intermediaries, but not to those who, like Mr Mehta, are aware of the infringement of intellectual property rights and play an active part in such infringement. In its decision to refer, the Tallinna Ringkonnakohus (Court of Appeal, Tallinn) states that it has doubts as to the compatibility of Estonian national law with EU law, in particular, firstly, of Article 60(2) of the Estonian Law on trade marks with Article 4(c) of Directive 2004/48 on the enforcement of intellectual property rights, and, secondly, of Articles 12 to 14 of Directive 2000/31 on certain legal aspects of information society services with the Estonian provisions transposing them into Estonian national law, that is, Articles 8 to 10 of the Estonian Law on information society services.

**Legal standing of a body for the collective representation of trade mark proprietors. First question to the CJ.** Is Article 4(c) of Directive 2004/48 to be interpreted as meaning that Member States are required to recognise bodies collectively representing trade mark proprietors as persons with standing to pursue legal remedies in their own name to defend the rights of trade mark proprietors and to bring actions before the courts in their own name to enforce the rights of trade mark proprietors? Pursuant to Article 4(c) of Directive 2004/48, interpreted in the light of recital 18 of the same directive, Member States are required to recognise, as persons entitled to seek application of measures, procedures and remedies, intellectual property collective rights-management bodies which are regularly recognised as having a right to represent holders of intellectual property rights, insofar as permitted by and in accordance with the provisions of the applicable law.

**Ruling of the CJ.** Article 4(c) of Directive 2004/48/EC of the European Parliament and of the Council of 29 April 2004 on the enforcement of intellectual property rights must be interpreted as meaning that the Member States are required to recognise a body collectively representing trade mark proprietors, such as the entity at issue in the case in the main proceedings, as a person entitled to seek, in its own name, the application of the remedies laid down by that directive, to defend the rights of the trade mark proprietors, and to bring legal proceedings, in its own name, to enforce said rights, on condition that said body is regarded by national law as having a direct interest in the defence of such rights and that said law allows it to bring legal proceedings to that end, these being matters for the referring court to verify.

**Liability of a provider of IP address rental and registration services allowing the anonymous use of domain names and websites. Second question to the CJ.** By its second question, the referring court asks, in essence, whether Articles 12 to 14 of Directive 2000/31 must be interpreted as meaning that the limitations of liability for which they provide apply to the provider of an IP address rental and registration service allowing domain names to be used anonymously. In the context, the purpose of the question concerns the criteria serving to establish whether a service such as that at issue in the main proceedings is of a merely technical, automatic and passive nature.

**Ruling of the CJ.** Articles 12 to 14 of Directive 2000/31/EC of the European Parliament and of the Council of 8 June 2000 on certain legal aspects of information society services, in particular electronic commerce, in the Internal Market ('Directive on electronic commerce') must be interpreted as meaning that the limitations of liability for which they provide apply to the provider of an IP address rental and registration service allowing the anonymous use of internet domain names, such as that at issue in the case in the main proceedings, inasmuch as that service falls within the scope of one of the categories of service referred to in those articles and meets all the corresponding conditions, insofar as the activity of such a service provider is of a merely technical, automatic and passive nature, implying that they have neither knowledge of nor control over the information transmitted or cached by his customers, and insofar as they do not play an active role in allowing those customers to optimise their online sales activity, these being matters for the referring court to verify.



## VIII. OTHER

### A. Restriction of the list of goods and services

♦[T-314/17](#); **MEZZA**; *Nosio SpA v EUIPO*; Judgment of 31 May 2018; EU:T:2018:315; Language of the case: IT. The applicant sought to register the word mark **MEZZA** as an EUTM for *alcoholic beverages, in particular wines and sparkling wines* in Class 33. The Office refused to register the mark on the grounds of Article 7(1)(b) EUTMR and Article 7(1)(c) EUTMR. Before the Board of Appeal (BoA) the applicant requested to restrict the list of goods to *alcoholic beverages, in particular wines and sparkling wines, contained in bottles and/or containers with a capacity greater than or less than 37.5 cl*. The BoA dismissed the applicant's appeal. Firstly, it found that the restriction of the list of goods was inadmissible; secondly, that the mark was devoid of distinctive character and that it was descriptive for the goods in question. The applicant appealed to the General Court (GC), relying on four pleas in law: (i) infringement of Article 49(1) EUTMR, (ii) infringement of Article 94 EUTMR, (iii) infringement of Article 7(1)(b) EUTMR and (iv) infringement of Article 7(1)(c) EUTMR. **Restriction of the list of goods.** The requested restriction was rejected as it would likely lead to legal uncertainty as to the extent of protection of the mark, in particular for third parties, who would not be aware of the exclusion of bottles with a capacity of 37.5 cl from protection (para. 37).

♦[T-471/17](#); **EDISON (fig.)**; *Edison SpA v EUIPO*; Judgment of 7 December 2018; EU:T:2018:887; Language of the case: IT. In 2003 the EUTM proprietor applied for the figurative mark 'EDISON' as an EUTM for all the goods covered by the general indications in Class 4. The mark was registered in 2013. In 2015, the EUTM proprietor requested the Office to modify the previous list of goods by limiting it. The Office partly upheld the limitation request except for *electrical energy*, because no such product existed in the list of goods in Class 4 of the 8th Nice Classification, which is the applicable edition in this case. The EUTM proprietor appealed and the Board of Appeal (BoA) endorsed the Office's conclusion, stating that by accepting *electrical energy* the scope of protection of the sign would be unduly widened. The EUTM proprietor filed an action with the General Court (GC) relying on two pleas in law: (i) infringement of Article 57 EUTMR in conjunction with Article 111 EUTMR and (ii) infringement of Article 94 EUTMR. **Scope of protection of Class 4 of the 8th Nice Classification.** The BoA rightly considered that the scope of protection of Class 4 comprises both the everyday and usual meaning of the general indications constituting its heading, and the alphabetical list of classes featuring in that edition of the Nice Classification. There is no doubt that the expression 'electrical energy' does not appear anywhere under Class 4 in the eighth edition. That expression was included in the alphabetical list of goods in Class 4 only from the ninth edition onwards (para. 36). 'Electrical energy' is of an intangible nature, which is difficult to reconcile with the common and ordinary meaning of the concept of 'illuminants' (para. 39). Although, undeniably, lamps and electric arcs produce light, that mere argument does not suffice to conclude that 'electrical energy' can be considered as part of *illuminants* (para. 40). 'Electrical energy' is intangible and cannot be included in the category *fuels* because that category consists of combustible materials (in solid, liquid or gaseous form) used to produce the 'electrical energy'. Therefore, 'electrical energy' is the result of combustion and not a material that provokes the combustion (para. 43). The fact that 'electrical energy' is analogous to other 'fuels', according to a recent WIPO declaration, means that it is similar from a functional point of view, but not that it is included in the concept of 'fuels' (para. 44). On the concept of 'fuels', it must be considered that in 2003, the use of electrical energy as a means for powering motors was negligible in the context of the EU, since it is a technology that, although contemplated and researched in the past, has only been



perfected, and thus made accessible to the wider public, in the last decade (para. 53). Failure to state reasons. The EUTM proprietor was given the opportunity to be heard on all points of fact and law on which the BoA based its decision. The continuity in terms of their functions between the different units of the Office enables the BoA to complement the Office’s reasoning or dismiss the appeal on the basis of a slightly different reasoning from that used in the first instance decision (para. 62). The contested decision contains an explanation of the reasons which led to the dismissal of the limitation request, and which is sufficiently detailed to allow the EUTM proprietor to understand the reasoning of the BoA and the GC (para. 71).

**B. EU collective marks**

♦[T-328/17](#); **BBQLOUMI (fig.) / HALLOUMI et al.**; *Foundation for the Protection of the Traditional Cheese of Cyprus named Halloumi v EUIPO*; Judgment of 25 September 2018; EU:T:2018:594; Language of the case: EN

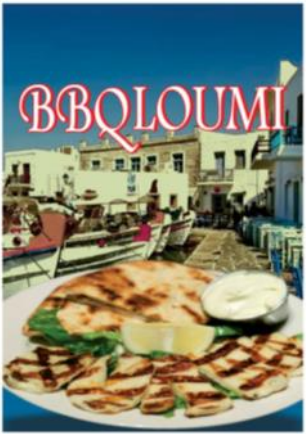
EUTM application	Earlier trade mark
	<p style="text-align: center;"><b>HALLOUMI</b></p>

The applicant sought to register the figurative mark above as an EUTM for goods and services in Classes 29, 30 and 43. An opposition based on the earlier EU collective word mark **HALLOUMI** registered for *cheeses* in Class 29, was filed pursuant to Article 8(1)(b) and Article 8(5) EUTMR. The Opposition Division (OD) dismissed the opposition and the opponent filed an appeal. The Board of Appeal (BoA) dismissed the appeal, finding there was no likelihood of confusion (LOC) given the weak distinctive character of the earlier mark, the low degree of visual similarity between the signs, the lack of phonetic and conceptual similarity and the varying degrees of similarity for some of the goods covered by the marks. The opponent filed an action with the General Court (GC), relying on a single plea in law: infringement of Article 8(1)(b) EUTMR. **Relevant public.** The relevant public is the EU general public (para. 27). **Comparison of the goods.** The goods are identical (cheese) (para. 27). **Comparison of the signs.** Although the term ‘bbqloumi’ will attract the public’s attention, the public will also focus on the representation of the plate of food due to its presence in the foreground. The figurative representation is visually co-dominant and as regards the word element, more weight should be given to its initial part, namely ‘bbq’, rather than its final part ‘loumi’. Therefore, insofar as ‘loumi’ does not constitute a separate element in the word ‘bbqloumi’ and as it is the element on which the signs coincide, the visual similarity is low (para. 62). The five letters, ‘loumi’, appear in the earlier mark and in



the word element of the contested mark, and this leads to a certain degree of phonetic similarity, which is low due to the final position of those letters in the contested mark and the different number of syllables (para. 64). Although the earlier mark conveys the concept of halloumi cheese, it cannot be ruled out that, to a certain extent, the contested mark conveys a similar concept. The BoA's argument that the concept of 'halloumi' represents a cheese and not the commercial origin of the designated product or of the proprietor of the mark is ineffective, since it is relevant only at the stage of assessing the LOC and not at that of the conceptual comparison (para. 66). In fact, for the part of the public familiar with halloumi cheese, in this case a not insignificant part of the general public of the EU, the group of the last five letters 'loumi' can be understood as referring to the concept of halloumi cheese cooked or grilled on a barbecue (para. 67). The figurative elements comprising a background showing a Mediterranean environment, introducing a link with the geographical position of Cyprus as a Mediterranean island, and a plate of food showing marks of grilling in the foreground, clearly reinforce the concept conveyed by the word element (para. 68). **Collective mark and distinctiveness.** The registration as a collective mark cannot per se give rise to a presumption that the mark has an average degree of distinctive character (para. 70). An analysis of the evidence as regards the perception of the earlier mark by the relevant public, including, inter alia, data relating to exports, sales, marketing and communication efforts, publications in various journals and works, showed that the word 'halloumi' denoted a particular type of cheese produced according to certain features and had done so for a long time, but did not identify it as belonging to anyone who marketed the product (para. 42). The evidence submitted was, furthermore, insufficient to establish intensive use as a trade mark designating cheeses (para. 70). **Likelihood of confusion.** There cannot be any LOC on the part of the relevant public since the existence of a visual, phonetic and conceptual similarity is not, for an earlier descriptive mark with a low degree of distinctiveness, sufficient to give rise to a presumption of LOC (para. 71).

♦[T-416/17](#); **fino Cyprus Halloumi Cheese (fig.) / HALLOUMI (Collective Mark)**; *Foundation for the Protection of the Traditional Cheese of Cyprus named Halloumi v EUIPO*; Judgment of 23 November 2018; EU:T:2018:834; Language of the case: EN

EUTM application	Earlier trade mark
	<p style="text-align: center;"><b>HALLOUMI</b></p>

The applicant sought to register the figurative mark above as an EUTM for goods in Class 29 (*cheese made out of cow's milk and/or sheep's milk and/or goat's milk (from any milk proportion and combination); rennet*). An opposition based on the earlier EU collective word mark **HALLOUMI** registered for goods in Class 29 (*cheeses*), was filed pursuant to Article 8(1)(b) EUTMR and Article 8(5) EUTMR. The Opposition Division (OD) dismissed the opposition, so the opponent filed an appeal. The Board of Appeal (BoA) compared the marks and found that there was no visual, phonetic or conceptual similarity. The opponent filed an action before the General Court (GC), relying on a single plea in law: infringement of Article 8(1)(b) EUTMR. **Relevant public.** Contrary to the opponent's submissions, the BoA did not seek to limit its analysis to the public of the UK only, but has merely referred to the perception of the term 'fino' by that public on account of its resemblance to the English word 'fine', and its meaning in Spanish or Italian, solely in assessing the distinctiveness of



that term as it appears in the contested trade mark (para. 31). The relevant public is the EU average end consumer with an average level of attention (para. 30). **Similarity of the goods.** The goods are identical (para. 30). **Similarity of the signs.** (i) Visual similarity is low. The word ‘fino’ is dominant because of its central position and its size, colour and inclusion in a golden, oval background, which serves to highlight it. The common word element ‘halloumi’, situated in the lower part of the sign, is also in a central position, written in white letters on a red background, enabling it to easily stand out; however, it is the sole element composing the earlier mark. The figurative elements of the contested mark do not alter the impression, since they are not very original and do not modify the visibility of the word element ‘halloumi’ (paras 61-62). (ii) It cannot be excluded that part of that public, albeit a minority, may read the mark in full or pronounce the word ‘fino’ followed by the word ‘halloumi’. The fact that the earlier mark is contained within the contested mark inevitably results in a phonetic similarity, however, due to the different number of syllables, this must be regarded as low (para. 64). (iii) The series of three words ‘cyprus halloumi cheese’ is only very weakly distinctive, because it is linked with the goods designated by the contested mark. This does not, however, mean that the words, in particular the word ‘halloumi’, cannot be considered individually by a part of the relevant public. Therefore, there is a low degree of conceptual similarity (para. 66). **No bearing on decision.** The fact that the BoA described the earlier mark as a UK national trade mark is obviously an error of fact with no effect on the legality of that decision (para. 27).

♦ [T-702/17](#); **PAP PAPOUIS HALLOUMI / HALLOUMI (I)**; *Foundation for the Protection of the Traditional Cheese of Cyprus named Halloumi v EUIPO*; Judgment of 23 November 2018; EU:T:2018:832; Language of the case: EN

EUTM application	Earlier trade mark
	<p style="text-align: center;"><b>HALLOUMI</b></p>

The applicant sought to register the figurative mark above as an EUTM for goods in Class 29 (*cheese made out of cow’s milk and/or sheep’s milk and/or goat’s milk (from any milk proportion and combination), rennet*). An opposition based on the earlier EU collective word mark **HALLOUMI** registered for goods in Class 29 (*cheese made from sheep’s and/or goat’s milk; cheese made from blends of cow’s milk; all included in Class 29*), was filed pursuant to Article 8(1)(b) EUTMR and Article 8(5) EUTMR. The Opposition Division (OD) dismissed the opposition, so the opponent filed an appeal. The Board of Appeal (BoA) compared the marks and found that there was no visual, phonetic or conceptual similarity. It found that, given the low inherent distinctiveness of the earlier mark and since the latter was not geographically descriptive, it could not fall within the exception of Article 74(2) EUTMR, which authorises the registration of an EU collective mark that is descriptive. With regard to the enhanced distinctiveness acquired through use of the earlier mark, the evidence adduced is not relevant, since it only shows use of the term ‘halloumi’ as a generic name designating a speciality cheese of Cyprus, but not as an EU collective mark. The opponent filed an action before the General Court (GC), relying on a single plea in law: infringement of Article 8(1)(b) EUTMR. **Relevant public.** The relevant public is made up of average end consumers, given that cheese is a product that everyone consumes almost daily (para. 12). **Similarity of the signs.** (i) Visual similarity is low: although the common word element ‘halloumi’ is in a central position, written in stylised, white characters



surrounded by blue and gold, however, it is the sole element composing the earlier mark. The figurative elements of the contested mark do not alter that impression, since they are not very original and do not modify the word element ‘halloumi’ (paras 54-55). (ii) It cannot be excluded that the relevant public will read the three, equally dominant, elements of the contested mark in full. The fact that the earlier mark is contained within the contested mark necessarily entails phonetic similarity when the three elements forming the expression ‘pap papouis halloumi’ are pronounced. However, the degree of similarity is low due to, inter alia, the different number of syllables (para. 57). (iii) The elements ‘pap’ and ‘papouis’ are clearly distinctive and dominant in the contested mark, but the concept conveyed by the earlier mark via the word ‘halloumi’ (which might be considered individually, despite its weak distinctiveness) must lead to a finding that there is a low degree of conceptual similarity (para. 59). **Previous judgments.** The configuration of the earlier mark is different from the one in the judgments invoked by the Office regarding the common element, since the word ‘halloumi’ neither forms part of a larger word element, nor a series of words. Therefore, it retains its autonomy and, consequently, its visibility as regards the public. The solution arising from the three judgments, in which the common word element was incorporated into a longer word element and could be considered as constituting an inseparable unit, cannot be transposed to the present case. It cannot be ruled out that, in the overall impression produced by the contested mark, the word ‘halloumi’ may be taken into consideration (paras 51-52).

♦**T-253/17; EIN KREIS MIT ZWEI PFEILEN (fig.); Der Grüne Punkt — Duales System Deutschland GmbH v EUIPO**; Judgment of 12 December 2018; EU:T:2018:909; Language of the case: DE. The EUTM proprietor registered the collective figurative mark ‘EIN KREIS MIT ZWEI PFEILEN’ as an EUTM for goods and services in Classes 1 to 42. The regulations governing use of the mark that had been submitted with the application for registration state, inter alia, in point 6, that the mark had been created ‘to enable consumers and businesses to recognise packaging included in the dual system and for which a sum had been paid towards financing the system, as well as goods packaged in this way, and to distinguish them from other packaging and goods ...’ A revocation application was filed pursuant to Article 58 EUTMR. The Cancellation Division (CD) partially upheld the revocation application, namely for all the goods in Classes 1 to 34 with the exception of those consisting of different forms of packaging in Classes 6, 17, 18, 20, 21, 22 and 24. The proprietor filed an appeal, which the Board of Appeal (BoA) dismissed. It found that the owner had not proved that, in relation to goods other than packaging, it had used the contested mark in accordance with its basic function, namely to guarantee the origin of the contested goods. Furthermore, the owner had not succeeded in proving that the purpose of the use of the contested mark was to create or maintain an outlet for those goods. All the documents produced related to the use of the contested mark exclusively with regard to sales packaging. The proprietor appealed to the General Court (GC), relying on a sole plea in law: infringement of Article 18(1) EUTMR in conjunction with Article 74 EUTMR. **Proof of use.** Proof of genuine use of the contested mark on packaging may constitute proof of genuine use of the mark for the packaged goods themselves if the proprietor proves that the relevant public perceives such use of the mark on the packaging as constituting use as a mark, that is, as an identifier of the commercial origin, for the packaged goods (paras 34-35). **Relevant public.** The contested goods primarily targeted the general public but also to some extent specialists in the fields of agriculture, commerce and industry. This target public would pay a normal to high level of attention when purchasing the goods (para. 36). From the point of view of the relevant public, the proprietor had not proved that it had used the contested mark in accordance with a mark’s basic function of guaranteeing the identity of origin of the contested goods (para. 37). Rather, the relevant public understood the use of the mark on the packaging as an indication that the packaging could be collected and





reused according to a certain system, namely the ‘dual system’ (para. 38). The relevant public was perfectly capable of distinguishing between a mark that indicated the commercial origin of goods and a mark that indicated the recovery of empty and used packaging after the consumer had unpacked, used or consumed the goods themselves, even if packaging and goods appeared to be a ‘unit’ at the time of sale. Moreover, the evidence adduced by the proprietor showed that the goods themselves were regularly designated by marks belonging to different companies (para. 41). It followed that use of the contested mark as a collective mark designating the goods of the members of an association to distinguish those goods from those of undertakings that were not part of that association would be perceived by the relevant public as use relating to packaging. The intangible quality claimed by the proprietor and attributed to the contested mark, that is to say the ecological behaviour of the undertaking by virtue of its affiliation to the proprietor’s licence agreement system, would be attributed by the relevant public to the fact that the packaging could be ecologically treated and not to such treatment of the packaged goods themselves (para. 42). Consequently, how the contested mark was understood by the relevant public did not relate to an intangible quality of the contested goods, but to an intangible quality of the packaging of those goods, namely that the packaging belonged to the dual system administered by the proprietor (para. 43). Since the mark was known to the consumer only as an indication that the packaging waste designated by the mark could be disposed of through local collection facilities, the affixing of the contested mark on the packaging simply expressed the fact that the company concerned, and all other economic operators using the same mark on their packaging, complied with the requirements laid down in Directive 2008/98/EC on waste management (para. 44). In the unlikely event that the offers of competitors’ goods were identical, and the consumer were to decide his or her purchase merely on the basis of the quality of the packaging, the contested mark would not be creating or maintaining an outlet vis-à-vis other economic operators for the packaged goods, but only for the packaging itself (para. 45). The proprietor had therefore not proved genuine use of the mark for the contested goods; consequently, the action had to be dismissed (para. 46).

### C. Res judicata

♦ [T-879/16](#); **Vieta (fig.)**; *Sony Interactive Entertainment Europe Ltd v EUIPO*; Judgment of 8 February 2018; EU:T:2018:77; Language of the case: EN



The figurative trade mark above was registered as an EUTM for goods in Class 9. The trade mark was then transferred to Marpefa SL (EUTM proprietor). An application for revocation was filed pursuant to Article 58(1)(a) EUTMR. The Cancellation Division (CD) dismissed the application for revocation in relation to the following goods: *loudspeakers, loudspeaker systems, sound amplifiers and computers, video screens, apparatus for the reproduction of sound and images, television sets, record players*. The revocation’s applicant appealed and the Board of Appeal (BoA) dismissed the appeal, insofar it found that genuine use had been proved for the above goods. The revocation applicant filed an action before the General Court (GC), which was upheld partially, since the GC found that the term *apparatus for the reproduction of sound and images* was not defined sufficiently ‘precisely and narrowly’. The GC annulled the BoA decision insofar as it found that genuine



use of the contested mark had been proved for *apparatus for the reproduction of sound and images*. The case was referred back to the BoA, which dismissed the appeal, stating that following the partial annulment of the first decision by the first GC's judgment, it had to examine whether the contested trade mark had been genuinely used for *apparatus for the reproduction of sound and images* during the relevant period. It stated that the term *apparatus for the reproduction of sound and images* was 'a specific term, and a synonym of "television sets", sufficiently clear and precise', and that it was not part of the heading of Class 9. The revocation applicant filed an action before the GC, relying on two pleas in law: (i) infringement of Article 72(6) EUTMR and (ii) breach of the principle that the applicant must identify the goods or services for which the protection of the EU trade mark is sought with sufficient clarity and precision. *Res judicata* extends only to the matters of fact and law actually or necessarily settled by the judicial decision in question. The force of *res judicata* attaches not only to the operative part of that decision, but also to the ratio decidendi of that decision, which is inseparable from it (para. 31). The BoA clearly disregarded the first GC's judgment by stating, in total contradiction with the findings of the GC which had acquired the force of *res judicata*, that the term *apparatus for the reproduction of sound and images* had a clear and specific content and covered only a single type of product, namely television sets. The BoA inferred from the above that proof of genuine use had been adduced for *apparatus for the reproduction of sound and images*. It is therefore also in total contradiction with point 1 of the operative part of the first judgment (which had also acquired the force of *res judicata*), that the BoA rejected the appeal and reaffirmed that the first BoA's decision was well founded (para. 41). Therefore, the BoA did not take the necessary measures to comply with the GC's judgment.

♦[T-2/17](#); **MASSI / MASI et al.**; *SRL v EUIPO*; Judgment of 3 May 2018; EU:T:2018:243; Language of the case: EN. The predecessor in title of the EUTM proprietor was granted registration of the word mark **MASSI** as an EUTM for, inter alia, goods in Class 12. An application for invalidity was filed for those goods pursuant to, inter alia, Article 60(1)(a) EUTMR in conjunction with Article 8(1)(b) EUTMR. The Cancellation Division (CD) dismissed the application for invalidity because it related to the same goods, was partly identical as regards the cause of action and subject matter, and concerned parties connected to those involved in application No 5 069 C for a declaration of invalidity. This earlier proceeding was filed by Haro Bicycle Corp. ('Haro'), and had been rejected by the Office in a decision having the force of *res judicata*. The Board of Appeal (BoA) upheld the invalidity applicant's appeal and declared the EUTM to be invalid for all the contested goods. It found that the conditions laid down in Article 63(3) EUTMR were not satisfied, as the invalidity applicant was not the same entity as in earlier proceedings No 5 069 C; that the earlier mark was still well known for bicycles and parts thereof in Italy; and that there was a likelihood of confusion (LOC) between the earlier well-known mark **MASI** and the registered EUTM, **MASSI**. The EUTM proprietor filed an action before the General Court (GC), relying on two pleas in law: (i) infringement of Article 63(3) EUTMR and (ii) infringement of Article 60(1)(a) EUTMR in conjunction with Article 8(2)(c) EUTMR. **Res judicata**. The condition that the parties be the same, laid down by Article 63(3) EUTMR, was not fulfilled, as Haro and the invalidity applicant are two separate entities. In any event, even if a broader interpretation of the concept of the identity of the parties could be accepted, such interpretation would not be capable of calling that conclusion into question (paras 25-27).

♦[T-424/17](#); **FRUIT**; *Fruit of the Loom, Inc. v EUIPO*; Judgment of 22 November 2018; EU:T:2018:824; Language of the case: EN. The EUTM proprietor registered the word mark **FRUIT** as an EUTM for *clothing, footwear, headgear* in Class 25. A revocation application was filed pursuant to Article 58 EUTMR. The Cancellation Division (CD) upheld the



revocation application. The EUTM proprietor filed an appeal. The Board of Appeal (BoA) dismissed the appeal. It found that genuine use of the mark had not been proven. The proprietor filed an action with the General Court (GC). The GC upheld the action. It found that the BoA's assessment of the evidence and the circumstances of the case did not satisfy the criteria laid down by case-law and referred the case back to the BoA. The BoA dismissed the proprietor's appeal. It found that insofar as the contested mark had not been genuinely used for *footwear and headgear*, it had to be declared revoked for those goods. As regards 'clothing', the evidence produced could not be regarded as containing any indication of use of the contested mark. Furthermore, even if it were considered that the goods presented in the various catalogues relied on by the proprietor bore the contested mark, the commercial acts relied on by the proprietor were not sufficient to classify the use claimed as genuine. The proprietor merely asserted that it had participated in a single fashion trade fair, held in Berlin in July 2012, and sent out catalogues. Those commercial acts, seen in the light of the proprietor's decision to stop the launch of the 'Born in the USA' clothing range, a decision that was not the result of an unsuccessful attempt to market its goods, were insufficient to show that the contested mark had been genuinely used. The proprietor appealed to the GC, relying on two pleas in law: (i) infringement of Article 18(1) EUTMR and (ii) infringement of Article 72(6) EUTMR. **Evidence of use.** Statements in writing can only be attributed probative value if they are supported by other evidence, which is not the case here (para. 71). Insofar as some of the items of evidence refer to the **Fruit of the Loom** trade mark, they cannot be considered relevant in this case, which concerns the trade mark **FRUIT** alone (para. 73). A list of names and addresses of the recipients of invitations to a trade fair does not in itself prove that brochures, catalogues and samples were distributed to them even if the list provides details on the allocation of the number of sample sets and brochures to customers, external agents and sales personnel in the EU (paras 88-89). None of the uses of the word element 'fruit' other than its use as a trade mark can be taken into account when assessing the genuineness of its use (para. 110). Therefore, the proprietor's employees use of the word 'fruit' to refer to the proprietor, the proprietor's use of the word 'fruit' to refer to its goods or the proprietor's use of the word 'fruit' on social media do not constitute evidence capable of proving genuine use of the mark during the relevant period, since that evidence alludes to solely internal use of the contested mark (para. 112).

#### D. Copyright

**C-149/17; Bastei Lübbe; Bastei Lübbe GmbH & Co. KG v Michael Strotzer**, Preliminary ruling of 18 October 2018; EU:T:2018:841; Language of the case: DE. The request for a preliminary ruling was made in the course of proceedings between Bastei Lübbe GmbH & Co. KG, a publisher, and Mr Michael Strotzer concerning an action for damages as a result of copyright infringement through file-sharing. Bastei Lübbe is the holder, as a phonogram producer, of the copyright and related rights in the audio version of a book. Mr Strotzer is the owner of an internet connection through which the audio book was shared, for downloading, with an unlimited number of users of a peer-to-peer internet exchange. An expert attributed the IP address in question to Mr Strotzer. Bastei Lübbe brought an action before the Amtsgericht München (Local Court, Munich, Germany) against Mr Strotzer for copyright infringement and damages. However, Mr Strotzer denies having himself infringed copyright and maintains that his connection was sufficiently secure. In addition, he asserts that his parents, who live in the same household, also had access to that connection but that to his knowledge they did not have the work in question on their computer, were not aware of the existence of the work and did not use the online exchange software. The Amtsgericht München dismissed Bastei Lübbe's action for damages on the grounds that Mr



Strotzer could not be held liable for copyright infringement, because he had stated that his parents also had access to the internet connection. Bastei Lübbe appealed before the Landgericht München I (District Court, Munich, Germany). This court was inclined to hold Mr Strotzer liable in that it does not follow from his explanations that a third party used the internet connection at the time of the infringement and therefore he is highly likely to have committed the infringement. However, according to the case-law of the Bundesgerichtshof (Federal Court of Justice, Germany), having regard to the fundamental right to protection of family life, such a defence is sufficient under German law to exclude the owner of the internet connection from liability. In those circumstances, the Landgericht München I decided to stay proceedings and to refer the following questions to the court for a preliminary ruling: ‘1. Should Article 8(1) and (2), in conjunction with Article 3(1), of Directive 2001/29/EC be interpreted as meaning that “effective and dissuasive sanctions” for infringements of the right to make works available to the public are still provided for even when the owner of an internet connection used for copyright infringements through file-sharing is excluded from liability to pay damages if the owner of that internet connection can name at least one family member who, besides him or her, might have had access to that internet connection, without providing further details, established through appropriate investigations, as to when and how the internet was used by that family member? 2. Should Article 3(2) of Directive 2004/48/EC be interpreted as meaning that “effective” measures for the enforcement of intellectual property rights are still provided for even when the owner of an internet connection used for copyright infringements through file-sharing is excluded from liability to pay damages if the owner of that internet connection can name at least one family member who, besides him or her, might have had access to that internet connection, without providing further details, established through appropriate investigations, as to when and how the internet was used by that family member?’ Since both questions raise the same legal problem, they have been answered together by the CJEU (paras 26-28). Article 8(1) of Directive 2001/29 read in the light of recital 58 thereof, states that the Member States are to provide for appropriate sanctions and remedies for infringements of the rights and obligations set out in that Directive and are to take all the measures necessary to ensure that those sanctions and remedies are applied. That provision also states that those sanctions are to be effective, proportionate and dissuasive. Article 3(2) of Directive 2004/48 states that the measures, procedures and remedies provided for by the Member States in respect of the means of enforcing intellectual property rights are to be effective, proportionate and dissuasive (paras 31, 34). It is clear that under German law, as interpreted by German courts, the owner of an internet connection by means of which copyright has been infringed is presumed to have committed that infringement, if the IP address in question has been correctly attributed to him and that no other person was able to use that connection at the time of the infringement. However, that presumption may be rebutted if persons other than the owner of the internet connection might have had access to that connection. Furthermore, if a family member of that owner had access to that connection, the owner may, having regard for the fundamental right to the protection of family life, escape liability merely by naming a family member without being required to provide further details as to when and how the internet was used by that family member (paras 35-36). The present request for a preliminary ruling thus raises the question of the need to reconcile the requirements of the protection of various fundamental rights, namely the right to an effective remedy and the right to intellectual property, on the one hand, and the right to the protection of private and family life, on the other (para. 44). According to case-law, EU law requires that, when transposing directives, the Member States take care to rely on an interpretation of them that allows a fair balance to be struck between the various fundamental rights protected by the EU legal order (para. 45). As regards respect for private life, although Article 7 of the Charter of Fundamental Rights of the European Union grants protection to everyone, and is not confined only to family members of a



person who the judicial authorities have ordered to produce evidence, persons belonging to the same family may, as such, benefit from special protection allowing them not to be compelled to comply with an obligation requiring them to incriminate one another, where one or another of them is suspected of having committed an illegal act (paras 48-49). Nevertheless, by guaranteeing almost absolute protection for family members of the owner of an internet connection through which copyright infringements were committed by means of file-sharing, the national legislation at issue in the main proceedings cannot, contrary to the requirements laid down in Article 8(1) of Directive 2001/29/EC, be considered to be sufficiently effective and capable of ultimately leading to effective and dissuasive sanctions against the perpetrator of those infringements (para. 52). There is no fair balance where almost absolute protection is guaranteed for family members of the owner of an internet connection through which copyright infringements were committed by means of file-sharing. In the light of all the foregoing considerations, the joint answer to the two questions referred is the following: Article 8(1) and (2) of Directive 2001/29/EC of the European Parliament and of the Council of 22 May 2001 on the harmonisation of certain aspects of copyright and related rights in the information society, read in conjunction with Article 3(1) thereof, and Article 3(2) of Directive 2004/48/EC of the European Parliament and of the Council of 29 April 2004 on the enforcement of intellectual property rights must be interpreted as precluding national legislation, such as that at issue in the main proceedings, under which, as interpreted by the relevant national courts, the owner of an internet connection used for copyright infringements through file-sharing cannot be held liable to pay damages if he can name at least one family member who might have had access to that connection, without providing further details as to when and how the internet was used by that family member.

#### **E. Impact of the 23 June 2016 referendum on withdrawal of the United Kingdom from the EU**

♦[C-340/17 P](#); **ALCOLOCK**; *Alcohol Countermeasure Systems (International) Inc. v EUIPO*; Judgment of 29 November 2018; EU:C:2018:965; Language of the case: EN. The EUTM proprietor registered the word mark **ALCOLOCK** as an EUTM for goods and services in Classes 9, 37 and 42. An invalidity application was filed pursuant to Article 60(1)(a) EUTMR in conjunction with, inter alia, Article 8(1)(a) and (b) EUTMR and based on the earlier United Kingdom word mark **ALCOLOCK** for goods in Class 9. The Cancellation Division (CD) upheld the invalidity application. It found that the earlier mark had been genuinely used, that the goods and services in question were identical or similar, and that the signs at issue were identical. The invalidity applicant filed an appeal. The Board of Appeal (BoA) dismissed the appeal. It found that the invalidity applicant had established to the requisite legal standard that the earlier mark had been genuinely used in the United Kingdom, that some of the goods in question were identical, as were the signs at issue, and that there was a likelihood of confusion (LOC) between those signs within the meaning of Article 8(1) EUTMR. The proprietor appealed to the General Court (GC), contesting, in essence, the BoA's assessment of the genuine use of the earlier mark. The GC dismissed the appeal. It found that proof of genuine use of the earlier mark could be submitted by means of evidence relating to the use of another word mark consisting of the same sign, **ALCOLOCK**. The proprietor appealed to the Court of Justice of the European Union (CJ). **Impact of the 23 June 2016 referendum on withdrawal of the United Kingdom from the EU.** The GC may not, according to the case-law of the CJ, annul or alter a decision of the BoA on grounds that come into existence after its adoption (para. 116). The GC was thus not required to stay the proceedings pending before it following the United Kingdom's referendum on withdrawal from the EU on the ground, moreover purely hypothetical at that stage, that said withdrawal would retroactively affect the outcome of invalidity proceedings



based on an earlier trade mark of that Member State (para. 117). Furthermore, the mere communication by a Member State of its intention to leave the EU in accordance with Article 50 of the Treaty on European Union (TEU) does not have the effect of suspending the application of EU law in that Member State. Consequently, EU law continues in full force and effect in that Member State until the time of its actual withdrawal from the European Union (para. 118).

---

## ANNEX 1:

### Alphabetical List of GC and CJ Judgments and Important Orders in 2018 by nickname of trade mark

#### *Actions On Appeal From The Office*

**42 BELOW (FIG. MARK) / VODKA 42 (FIG. MARK);** Judgment of 24 October 2018 in Case [T-435/12](#); *Bacardi Co. Ltd v EUIPO*

**1000, 3000, 2000, 6000, 4000, 5000;** *Sata GmbH & Co. KG v EUIPO*; Judgment of 29 May 2018 in Cases [T-299/17](#); [T-300/17](#); [T-301/17](#); [T-302/17](#); [T-303/17](#); [T-304/17](#)

♦**100% Pfalz (fig.);** Judgment of 26 April 2018 in Case [T-220/17](#); *Pfalzmarkt für Obst und Gemüse eG v EUIPO*;

♦♦**3D (fig.);** Judgment of 19 June 2018 in Case [T-413/17](#); *Karl Storz GmbH & Co. KG v EUIPO*

€\$ **(fig.);** Judgment of 8 March 2018 in Case [T-665/16](#); *Cinkciarz.pl sp. z o.o. v EUIPO*

**Aa AROMAS artesanales (MARCA FIGURATIVA) / Aromas PERFUMARIA Beleza em todos os sentidos (MARCA FIGURATIVA) et al.;** Judgment of 25 April 2018 in Case [T-426/16](#); *Perfumes y Aromas Artesanales, S.L. v EUIPO*

**AKANTO / KANTOS;** Judgment of 25 September 2018 in Case [T-182/17](#); *Novartis v EUIPO*

♦**ALCOLOCK;** Judgment of 29 November 2018 in Case [C-340/17 P](#); *Alcohol Countermeasure Systems (International) Inc. v EUIPO*

♦**ALDI / ALDO (fig.);** Judgment of 25 October 2018 in Case [T-359/17](#); *Aldo Supermarkets v EUIPO*

**Alfrisa (fig.) / Frinsa F (fig.);** Judgment of 4 October 2018 in Case [T-820/17](#); *Frinsa del Noroeste, S.A v EUIPO*

**ALPINEWELTEN Die Bergführer (fig.);** Judgment of 2 May 2018 in Case [T-428/17](#); *Alpine Welten Bergführer GmbH & Co. KG v EUIPO*

♦♦**ANOKHI (fig.) / Kipling (fig.) et al.;** Judgment of 16 October 2018 in Case [T-548/17](#); *VF International Sagl v EUIPO*

**ANTONIO RUBINI / RUTINI (fig.) et al.;** Judgment of 11 July 2018 in Case [T-707/16](#);



*Enoitalia SpA v EUIPO*

♦ **apo (fig.) / DEVICE OF AN APPLE WITH A BITE (fig.) et al.**; Judgment of 13 September 2018 in Case [T-104/17](#); *Apple Inc. v EUIPO*

**avanti (fig.)**; Judgment of 23 January 2018 in Case [T-250/17](#); *Avanti v EUIPO*

♦ **BBQLOUMI (fig.) / HALLOUMI et al.**; Judgment of 25 September 2018 in Case [T-328/17](#); *Foundation for the Protection of the Traditional Cheese of Cyprus named Halloumi v EUIPO*

**BBQLOUMI / HALLOUMI et al.**; Judgment of 25 September 2018 in Case [T-384/17](#); *Republic of Cyprus v EUIPO*

**Becher**; Judgment of 5 July 2018 in Case [C-217/17 P](#); *Mast-Jägermeister SE v EUIPO*

♦ **BEPOST /ePOST (fig.) et al.**; Judgment of 20 February 2018 in Case [T-118/16](#); *Deutsche Post AG v EUIPO*

♦ **BeyBeni (fig.) / Ray-Ban (fig.) et al.**; Judgment of 8 May 2018 in Case [T-721/16](#); *Luxottica Group SpA v EUIPO*

**billiger-mietwagen.de**; Judgment of 25 January 2018 in Case [T-866/16](#); *SilverTours GmbH v EUIPO*

♦ **Bingo VIVA! Slots (fig.) / vive bingo (fig.)**; Judgment of 24 October 2018 in Case [T-63/17](#); *Grupo Orenes, S.L. v EUIPO*

♦ **BLACK LABEL BY EQUIVALENZA (fig.) / LABELL (fig.) et al.**; Judgment of 7 March 2018 in Case [T-6/17](#); *Equivalenza Manufactory, SL v EUIPO*

**BLUE**; Judgment of 12 June 2018 in Case [T-375/17](#); *Kludia Patricia Fenyves v EUIPO*

♦ **BOBO cornet www.bobo-cornet.com (fig.) / OZMO cornet (fig.)**; Judgment of 17 April 2018 in Case [T-648/16](#); *Şölen Çikolata Gıda Sanayi ve Ticaret AŞ v EUIPO*

**Business and technology working as one**; Judgment of 14 December 2018 in Case [T-7/18](#); *Inforsacom Logicalis GmbH v EUIPO*

**C=commodore (fig.)**; Judgment of 13 December 2018 in Case [T-672/16](#); *C=Holdings BV v EUIPO*

**Camele'on (fig.) / CHAMELEON**; Judgment of 27 September 2018 in Case [T-472/17](#); *Wilhelm Sihm jr. GmbH & Co. KG v EUIPO*

♦ **CAMOMILLA / CAMOMILLA (fig.)**; Judgment of 13 November 2018 in Case [T-44/17](#); *Camomilla Srl v EUIPO*

**CARACTÈRE**; Judgment of 12 December 2018 in Case [T-743/17](#); *Bischoff GmbH v EUIPO*

**CAVE DE TAIN (fig.)**; Judgment of 12 July 2018 in Case [T-774/16](#); *Consejo Regulador del Cava v EUIPO*



♦ **CCB (fig.) / CB (fig.) et al.**; Judgment of 6 December 2018 in Case [T-665/17](#); *China Construction Bank Corp. v EUIPO*

♦ **CERVISIA (fig.) / CERVISIA AMBAR**; Judgment of 7 December 2018 in Case [T-378/17](#); *La Zaragozana, SA v EUIPO*

**Celeson / CELESIO**; Judgment of 20 November 2018 in Case [T-36/18](#); *Asahi Intecc Co., Ltd v EUIPO*

**CIPRIANI / HOTEL CIPRIANI et al.**; Judgment of 1 March 2018 in Case [T-438/16](#); *Altunis-Trading, Gestão e Serviços, Lda v EUIPO*

**CK1/ CK (fig.)**; Judgment of 20 February 2018 in Case [T-45/17](#); *Kwang Yang Motor Co., Ltd v EUIPO*

**CLOS DE LA TORRE / TORRES et al.**; Judgment of 22 March 2018 in Case [T-806/16](#); *Agricola J.M., SL v EUIPO*

♦♦ **COFFEE ROCKS (fig.) / STARBUCKS COFFEE (fig.) et al.**; Judgment of 16 January 2018 in Case [T-398/16](#); *Starbucks Corp v EUIPO*

♦♦ **Coil Liner**; Judgment of 4 May 2018 in Case [T-188/17](#); *Bernard Krone Holding SE & Co. KG v EUIPO*

**COOKING CHEF GOURMET**; Judgment of 9 October 2018 in Case [T-697/17](#); *De Longhi Benelux SA v EUIPO*

♦ **COSIMO / COSIFLOR**; Judgment of 26 June 2018 in Case [T-739/16](#); *Akant Monika i Zbigniew Harasym sp.j. v EUIPO*

**Cot bumpers**; Judgment of 23 October 2018 in Case [T-672/17](#); *Mamas and Papas Ltd v EUIPO*

**cotecnica MAXIMA (fig.) / MAXIM Alimento Superpremium (fig.)**; Judgment of 12 June 2018 in Case [T-136/17](#); *Cotécnica, SCCL v EUIPO*

**COWBOYS HALLOUMI (fig.) / HALLOUMI et al.**; Judgment of 13 July 2018 in Case [T-847/16](#); *Republic of Cyprus v EUIPO*

**CRABS (fig.) / RAKOVYE SHEIKI KARAMEL (fig.)**; Judgment of 7 February 2018 in Case [T-795/16](#); *Moscow Confectionery Factory 'Krasnyiy oktyabr' OAO v EUIPO*

**CRABS (fig.) / DEVICE OF A CRAYFISH (fig.)**; Judgment of 7 February 2018 in Case [T-775/16](#); *Dochirnie pidpriemstvo Kondyterska korporatsiia 'Roshen' v EUIPO*

**Cuervo y Sobrinos LA HABANA 1882 (fig.) / CUERVO Y SOBRINO et al.**; Judgment of 10 October 2018 in Case [T-374/17](#); *Cuervo y Sobrinos 1882, S.L. v EUIPO*

**CHATKA (fig.) / CHATKA (fig.)**; Judgment of 25 April 2018 in Case [T-248/16](#); *Walfood SA v EUIPO*

**CHATKA / CHATKA (fig.)**; Judgment of 25 April 2018 in Case [T-312/16](#); *Walfood SA v*





EUIPO

♦ **DARSTELLUNG EINES GLEICHWINKLIGEN ACHECKS (fig.);** Judgment of 21 November 2018 in Case [T-460/17](#); *Carsten Bopp v EUIPO*

♦ **DARSTELLUNG EINES SCHUHES (fig.) / BALKENDARSTELLUNG AUF EINEM SCHUH (POSITIONSMARKE) et al.;** Judgment of 6 December 2018 in Case [T-638/16](#); *Deichmann SE v EUIPO*

**DARSTELLUNG VON VIER GRÜNEN QUADRATEN (posit.);** Judgment of 13 September 2018 in Case [T-184/17](#); *Leifheit AG v EUIPO*

♦ **Dating Bracelet (fig.);** Judgment of 20 March 2018 in Case [T-272/17](#); *Webgarden Szolgáltató és Kereskedelmi Kft v EUIPO*

♦ **Dayaday (fig.) / DAYADAY (fig.) et al.;** Judgment of 1 June 2018 in Case [T-900/16](#); *Casual Dreams, S.L.U v EUIPO*

**DEEP PURPLE / DEEP PURPLE;** Judgment of 4 October 2018 in Case [T-328/16](#); *Ian Paice v EUIPO*

**DEEP PURPLE / DEEP PURPLE;** Judgment of 4 October 2018 in Case [T-344/16](#); *Richard Hugh Blackmore v EUIPO*

**DEEP PURPLE / DEEP PURPLE;** Judgment of 4 October 2018 in Case [T-345/16](#); *Richard Hugh Blackmore v EUIPO*

♦ **deluxe (fig.);** Judgment of 4 July 2018 in Case [T-222/14 RENV](#); *Deluxe Entertainment Services Group Inc v EUIPO*

♦ **Desde 1972 Claro Sol Facility Services (fig.) / SOL (fig.);** Judgment of 8 March 2018 in Case [T-159/17](#); *Claro Sol Cleaning, SLU v EUIPO*

**Pebble beach surface pattern;** Judgment of 21 June 2018 in Case [T-228/16](#); *Haverkamp IP GmbH v EUIPO*

**Foot mat;** Judgment of 21 June 2018 in Case [T-227/16](#); *Haverkamp IP GmbH v EUIPO*

**Fahrradkörbe;** Judgment of 17 May 2018 in Case [T-760/16](#); *Basil BV v EUIPO*

♦ **Boxes [packaging];** Judgment of 7 February 2018 in Case [T-793/16](#); *Şölen Çikolata Gıda Sanayi ve Ticaret AŞ v EUIPO*

**Treillages;** Judgment of 25 April 2018 in Case [T-756/16](#); *Euro Castor Green v EUIPO*

♦ **Ice cream cornets [edible] (Packagings for -);** Judgment of 7 February 2018 in Case [T-794/16](#); *Şölen Çikolata Gıda Sanayi ve Ticaret AŞ v EUIPO*

♦ **Footwear;** Judgment of 14 March 2018 in Case [T-424/16](#); *Gifi Diffusion v EUIPO*

**Footwear;** Judgment of 14 March 2018 in Case [T-651/16](#); *Crocs, Inc v EUIPO*



**DEVICE OF TWO PARALLEL STRIPES (other) / DEVICE OF THREE PARALLEL STRIPES (fig.) et al.**; Judgment of 1 March 2018 in Case [T-629/16](#); *Shoe Branding Europe BVBA v EUIPO*

♦ **DEVICE OF A CROSS ON A SPORT SHOE SIDE (fig.)**; Judgment of 17 January 2018 in Case [T-68/16](#); *Deichmann SE v EUIPO*

**REPRESENTACION DE HOMBRE EN TRAJE HISTORICO (fig.)**; Judgment of 24 April 2018 in Case [T-183/17](#); *Menta y Limón Decoración, SL v EUIPO*

**DEVICE OF A PANTHER (fig.) / DEVICE OF A PANTHER (fig.) et al.**; Judgment of 30 January 2018 in Case [T-113/16](#); *Arctic Cat Inc. v EUIPO*

♦ **DEVICE OF A JUMPING ANIMAL (FIG. MARK) / PUMA (FIG. MARK) et al.**; Judgment of 28 June 2018 in Case [C-564/16 P](#); *EUIPO v Puma SE*

**DEVICE OF A PATTERN (fig.)**; Judgment of 13 September 2018 | Case [C-26/17 P](#); *Birkenstock Sales GmbH v EUIPO*

**DEVICE OF A SQUARE (fig.)**; Judgment of 31 January 2018 in Case [T-44/16](#); *Novartis AG v EUIPO*

♦ **DEVICE OF PIRELLI TYRE TREAD (fig.)**; Judgment of 24 October 2018 in Case [T-447/16](#); *Pirelli Tyre SpA v EUIPO*

♦ **DEVICE OF A WINGED BULL (fig.) / DEVICE OF A GRIFFIN (fig.) et al.**; Judgment of 15 March 2018 in Case [T-151/17](#); *Marriott Worldwide Corp. v EUIPO*

♦ **DEVICE OF COMPONENT OF PROTHESIS (fig.)**; Judgment of 3 May 2018 in Case [T-193/17](#), [T-194/17](#) and [T-195/17](#) (joined cases); *CeramTec GmbH v EUIPO*

♦ **DEVICE OF FOUR CROSSING LINES (fig.) / DEVICE OF FOUR CROSSING LINES (fig.) et al.**; Judgment 16 October 2018 in Case [T-581/17](#); *Asics Corporation v EUIPO*

♦ **DEVIN**; Judgment of 25 October 2018 in Case [T-122/17](#); *Devin AD v EUIPO*

♦ **DIAMOND ICE / DIAMOND CUT**; Order of 3 May 2018 in Case [T-234/17](#); *Siberian Vodka AG v EUIPO*

**DIETOX (fig.) / Diator (fig.)**; Judgment of 14 November 2018 in Case [T-486/17](#); *Foodterapia, SL v EUIPO*

♦ **DOLFINA**; Judgment of 7 June 2018 in Case [T-882/16](#); *Sipral World, SL v EUIPO*

**DONTORO dog friendship (fig.) / TORO et al.**; Judgment of 20 March 2018 in Case [T-390/16](#); *Grupo Osborne, SA v EUIPO*

♦ **Dry Zone**; Judgment of 20 September 2018 in Case [T-488/17](#); *Ghost — Corporate Management SA v EUIPO*

**D-TACK / TACK et al.**; Judgment of 10 October 2018 in Case [T-24/17](#); *LA Superquimica, SA v EUIPO*



**Dual Edge**; Judgment of 18 January 2018 in Case [T-804/16](#); *LG Electronics, Inc. v EUIPO*

♦ **EDISON (fig.)**; Judgment of 7 December 2018 in Case [T-471/17](#); *Edison SpA v EUIPO*

♦♦ **Eddy's Snackcompany / TEDDY et al.**; Judgment of 19 September 2018 in Case [T-652/17](#); *Eddy's Snack Company GmbH v EUIPO*

♦ **Eico/MAICO**; Judgment of 20 September 2018 in Case [T-668/17](#); *Maico Holding GmbH v EUIPO*

♦ **EIN KREIS MIT ZWEI PFEILEN (fig.)**; Judgment of 12 December 2018 in Case [T-253/17](#); *Der Grüne Punkt — Duales System Deutschland GmbH v EUIPO*

**EISKELLER (fig.) / KELER et al.**; Judgment of 19 June 2018 in Case [T-859/16](#); *Sociedad Anónima Damm v EUIPO*

**Electrically operated lifting column, in particular for tables**; Judgment of 18 October 2018 in Case [T-367/17](#); *Linak A/S v EUIPO*

**Electrically operated lifting column, in particular for tables**; Judgment of 18 October 2018 in Case [T-368/17](#); *Linak A/S v EUIPO*

♦♦ **EL TOFIO EI sabor de CANARIAS (fig.)**; Judgment of 25 October 2018 in Case [T-765/16](#); *Grupo Ganaderos de Fuerteventura, S.L. v EUIPO*

**EM**; Judgment of 25 September 2018 in Case [T-180/17](#); *EM Research Organization, Inc. v EUIPO*

♦♦ **EMCURE / Emcur et al.**; Judgment of 14 June 2018 in Case [T-165/17](#); *Emcur Gesundheitsmittel aus Bad Ems GmbH v EUIPO*

**Erdmann & Rossi; Erdmann & Rossi**; Order of 30 May 2018 in Case [T-664/16](#); *PJ v EUIPO*

♦♦ **EW (fig.) / WE**; Judgment of 4 May 2018 in Case [T-241/16](#); *El Corté Inglés, SA v EUIPO*

♦ **Exxtra Deep**; Judgment of 21 November 2018 in Case [T-82/17](#); *PepsiCo, Inc. v EUIPO*

**Fack Ju Göhte**; Judgment of 24 January 2018 in Case [T-69/17](#); *Constantin Film Produktion GmbH v EUIPO*

**FEEL FREE**; Judgment of 27 June 2018 in Case [T-362/17](#); *NCL Corporation Ltd v EUIPO*

**FEMIVIA / FEMIBION INTIMA et al.**; Judgment of 22 November 2018 in Case [T-59/18](#); *Endoceutics, Inc. v EUIPO*; *Endoceutics, Inc. v EUIPO*

♦ **fino Cyprus Halloumi Cheese (fig.) / HALLOUMI (Collective Mark)**; Judgment of 23 November 2018 in Case [T-416/17](#); *Foundation for the Protection of the Traditional Cheese of Cyprus named Halloumi v EUIPO*

♦ **fino Cyprus Halloumi Cheese (fig.) / HALLOUMI (CERTIFICATION MARK) et al.**;



Judgment of 23 November 2018 in Case [T-417/17](#); *Republic of Cyprus v EUIPO*

**fit+fun**; Judgment of 13 December 2018 in Case [T-94/18](#); *Multifit Tiernahrungs GmbH v EUIPO*

**FITNESS**; Judgment of 24 January 2018 in Case [C-634/16 P](#); *EUIPO v European Food*

♦ **FERMIN / FERMIPAN et al.**; Judgment of 22 November 2018 in Case [T-78/18](#); *AB Mauri Italy SpA v EUIPO*

**Flexagil (fig.)**; Judgment of 15 November 2018 in Case [T-831/17](#); *DRH Licensing & Managing AG v EUIPO*

**FLEXCUT**; Judgment of 4 October 2018 in Case [T-736/17](#); *Lincoln Global, Inc. v EUIPO*

♦♦ **FLUO. (fig.)**; Judgment of 11 October 2018 in Case [T-120/17](#); *M & T Emporia Elektronik-  
Elektronikon Eidon AE v EUIPO*

♦♦ **FLÜGEL / ... VERLEIHT FLÜGEL et al.**; Judgment of 4 October 2018 in Case [T-150/17](#); *Asolo Ltd v EUIPO*

♦ **FORM EINER FLASCHE (3D)**; Judgment of 3 October 2018 in Case [T-313/17](#); *Wajos GmbH v EUIPO*

♦ **FORM EINES BALLÄHNLICHEN KÖRPERS MIT KANTEN (3D)**; Judgment of 16 May 2018 in Case; [T-387/17](#); *Triggerball GmbH v EUIPO*

**Foto Paradies**; Judgment of 28 February 2018 in Case [T-843/16](#); *dm-drogerie markt GmbH & Co. KG v EUIPO*

♦ **FRANCE.COM (fig.) / France (fig.)**; Judgment of 26 June 2018 in Case [T-71/17](#); *France.com, Inc. v EUIPO*;

♦ **FRUIT**; Judgment of 22 November 2018 in Case [T-424/17](#); *Fruit of the Loom, Inc. v EUIPO*

♦♦ **FUNNY BANDS**; Judgment of 29 November 2018 in Case [T-214/17](#); *Out of the blue KG v EUIPO*

**FYYO / FIO et. al.**; Judgment of 22 November 2018 in Case [T-826/17](#); *TeamBank AG Nürnberg v EUIPO*

**GELB-GRAU (fig.)**; Judgment of 27 September 2018 in Case [T-595/17](#); *Demp BV v EUIPO*

**GiCapri “a giachett' e capri” (fig.) / CAPRI (fig.)**; Judgment of 26 June 2018 in Case [T-619/16](#); *Pasquale Sicignano v EUIPO*

♦♦ **GOLDEN BALLS / BALLON D'OR et al.**; Judgment of 17 October 2018 in Case [T-8/17](#); *Golden Balls Ltd v EUIPO*

**GN Laboratories / GNC et al.**; Judgment of 27 September 2018 in Case [T-712/17](#); *Christos Ntolas v EUIPO*



**GREEN STRIPES ON A PIN (col.)**; Judgment of 25 October 2018 in Case [C-433/17 P](#); *Enercon GmbH v EUIPO*

♦ **GROUP Company TOURISM & TRAVEL (fig.) / GROUP Company TOURISM & TRAVEL (fig.)**; Judgment of 19 April 2018 in Case [C-478/16 P](#); *EUIPO v Group OOD*

**Guidego what to do next (fig.) / GUIDOGO**; Judgment of 13 March 2018 in Case [T-346/17](#); *Hotelbeds Spain SL v EUIPO*

♦ **GUGLER (fig.) / GUGLER FRANCE**; Judgment of 25 September 2018 in Case [T-238/17](#); *Alexander Gugler v EUIPO*

**H2O+ (fig.)**; Judgment of 27 November 2018 in Case [T-824/17](#); *H2O Plus LLC v EUIPO*

**happy life**; Judgment of 25 September 2018 in Case [T-457/17](#); *Medisana AG v EUIPO*

**HIPANEMA (fig.) / Ipanema (fig.) et al.**; Judgment of 25 September 2018 in Case [T-435/17](#); *Grendene, SA v EUIPO*

**HISPANITAS JOY IS A CHOICE (fig.) / JOY**; Judgment of 30 January 2018 in Case [T-808/16](#); *Jean Patou Worldwide Ltd v EUIPO*

**H HOLY HAFERL HAFERL SHOE COUTURE (BILDMARKE) / HOLY et al.**; Judgment of 25 January 2018 in Case [T-367/16](#); *Brunner v EUIPO*

**holyGhost / HOLY**; Judgment of 20 April 2018 in Case [T-439/16](#); *holyGhost GmbH v EUIPO*

**HOUSE OF CARS**; Judgment of 17 April 2018 in Case [T-364/17](#); *Marcin Bielawski v EUIPO*

♦ **hp (fig.)**; Judgment of 24 April 2018 in Case [T-207/17](#); *Senetic S.A. v EUIPO*

♦ **HP**; Judgment of 24 April 2018 in Case [T-208/17](#); *Senetic S.A. v EUIPO*

♦ **HPC POLO / POLO et al.**; Judgment of 20 June 2018 in Case [T-657/17](#); *Gidon Anabi Blanga v EUIPO*

**iGrill**; Judgment of 31 January 2018 in Case [T-35/17](#); *Weber-Stephen Products LLC v EUIPO*

**iGrill**; Judgment of 17 October 2018 in Case [T-822/17](#); *Weber-Stephen Products LLC v EUIPO*

**InPost (fig.) / POST et al.** Judgment of 26 June 2018 in Case [T-537/15](#); *Deutsche Post AG v EUIPO*

♦ **JUMBO**; Judgment of 26 June 2018 in Case [T-78/17](#); *Jumbo Africa, S.L. v EUIPO*

**K (fig.) / K (fig.) et al.**; Judgment of 13 March 2018 in Case [T-824/16](#); *Kiosked Oy Ab v EUIPO*



♦**KHADI / KHADI**; Judgment of 29 November 2018 in Case [T-681/17](#); *Khadi and Village Industries Commission v EUIPO*

♦**Khadi Ayurveda / KHADI et al.**; Judgment of 29 November 2018 in Case [T-683/17](#); *Khadi and Village Industries Commission v EUIPO*

♦**khadi Naturprodukte aus Indien (fig.) / KHADI et al.**; Judgment of 29 November 2018 in Case [T-682/17](#); *Khadi and Village Industries Commission v EUIPO*

♦**KENZO ESTATE / KENZO**; Judgment of 30 May 2018 in Cases [C-85/16 P](#) and [C-86/16 P](#) (joined cases); *Kenzo Tsujimoto v EUIPO*

♦**KIMIKA / KAMIK**; Judgment of 16 October 2018 in Case [T-171/17](#); *M & K Srl v EUIPO*

**KINDERPRAMS / Kinder (fig.) et al.**; Judgment of 6 December 2018 in Case [T-115/18](#); *Tomasz Kawałko Trofeum v EUIPO*

♦**LABORATOIRES MAJORELLE / MAJORELLE et al.**; Judgment of 3 May 2018 in Case [T-429/17](#); *Laboratoire Majorelle v EUIPO*

**La Mafia SE SIENTA A LA MESA (fig.)**; Judgment of 15 March 2018 in Case [T-1/17](#); *La Mafia Franchises, SL v EUIPO*

**Le Coq de France / le coq (fig.)**; Judgment of 1 February 2018 in Case [T-457/16](#); *Aldi Einkauf v EUIPO*

**Leshare / LEXWARE**; Judgment of 15 November 2018 in Case [T-546/17](#); *Haufe-Lexware GmbH & Co. Kg v EUIPO*

**life coins / LIFE et al.**; Judgment of 15 October 2018 in Case [T-444/17](#); *CompuGroup Medical AG v EUIPO*

**LIGHTBOUNCE**; Judgment of 27 September 2018 in Case [T-825/17](#); *Carbon System Verwaltungs GmbH v EUIPO*

**Lion's Head / LION CAPITAL et al.**; Judgment of 14 June 2018 in Case [T-294/17](#); *Lion's Head Global Partners LLP v EUIPO*

**LION'S HEAD global partners (fig.) / LION CAPITAL et al.**; Judgment of 14 June 2018 in Case [T-310/17](#); *Lion's Head Global Partners LLP v EUIPO*

**LITECRAFT**; Judgment of 15 November 2018 in Case [T-140/18](#); *LMP Lichttechnik Vertriebs GmbH v EUIPO*

♦**LOTTE (fig.) / KOALA SCHÖLLER (fig.)**; Judgment of 12 July 2018 in Case [T-41/17](#); *Lotte Co. Ltd v EUIPO*

♦♦**LV POWER ENERGY DRINK (fig.) / LV (fig.)**; Judgment of 29 November 2018 in Case [T-372/17](#); *Louis Vuitton Malletier v EUIPO*

♦♦**LV BET ZAKŁADY BUKMACHERSKIE (fig.) / LV (fig.)**; Judgment of 29 November



2018 in Case [T-373/17](#); *Louis Vuitton Malletier v EUIPO*

**MAGELLAN**; Judgment of 27 February 2018 in Case [T-222/16](#); *Hansen Medical, Inc. v EUIPO*

♦ **MAIN AUTO WHEELS (fig.) / VW (fig.) et al.**; Judgment of 19 September 2018 in Case [T-623/16](#); *Volkswagen AG v EUIPO*

♦♦ **MASSI / MASI et al.**; Judgment of 3 May 2018 in Case [T-2/17](#); *SRL v EUIPO*

♦ **MASTER PRECISE /MASTERS COLORS PARIS (fig.)**; Judgment of 30 May 2018 in Case [C-519/17 P](#) and [C-522/17 P](#) to [C-525/17 P](#) (joined cases); *L'OréalSA v EUIPO*

♦ **M'Cooky / MR. COOK (fig.)**; Judgment of 26 April 2018 in Case [T-288/16](#); *Convivo GmbH v EUIPO*

♦ **Mega Liner**; Judgment of 4 May 2018 in Case [T-187/17](#); *Bernard Krone Holding SE & Co. KG v EUIPO*

**medialbo / MediaLB et al.**; Judgment of 25 July 2018 in Case [C-139/17 P](#); *QuaMa Quality Management GmbH v EUIPO*

**MEMORAME / MÉMORA et al.**; Judgment of 24 April 2018 in Case [T-221/17](#); *Mémora Servicios Funerarios SLU v EUIPO*

♦ **MESSI (fig.) / MASSI et al.**; Judgment of 26 April 2018 in Case [T-554/14](#); *Lionel Andrés Messi Cuccittini v EUIPO*

♦♦ **METABOX / META4 et al.**; Judgment of 16 January 2018 in Case [T-204/16](#); *Sun Media Ltd v EUIPO*

♦♦ **METAPORN / META4 et al.**; Judgment of 16 January 2018 in Case [T-273/16](#); *Sun Media Ltd v EUIPO*

♦ **MEZZA**; Judgment of 31 May 2018 in Case [T-314/17](#); *Nosio Spa v EUIPO*

**MicroSepar / SEPARSolidaria (fig.)**; Judgment of 17 October 2018 in Case [T-788/17](#); *Andreas Szabados v EUIPO*

♦ **MINERAL MAGIC / MAGIC MINERALS BY JEROME ALEXANDER et al.**; Judgment of 15 October 2018 in Case [T-7/17](#); *John Mills Ltd v EUIPO*

♦ **mobile.de**; Judgment of 28 February 2018 in Case [C-418/16 P](#); *mobile.de GmbH v EUIPO*

♦ **MOBILE LIVING MADE EASY**; Judgment of 22 March 2018 in Case [T-235/17](#); *Dometic Sweden AB v EUIPO*

♦ **MONSTER DIP (fig.) / MONSTER ENERGY (fig.) et al.**; Judgment of 13 December 2018 in Case [T-274/17](#); *Monster Energy Company v EUIPO*

**MULTIFIT**; Judgment of 13 December 2018 in Case [T-98/18](#); *Multifit Tiernahrungs GmbH v*



EUIPO;

◆◆**mycard2go**; Judgment of 15 May 2018 in Case [T-675/16](#), [T-676/16](#), [T-860/16](#); *Wirecard AG v EUIPO*

**N & NF TRADING / NF ENVIRONNEMENT (fig.) et al.**; Judgment of 7 June 2018 in case [T-807/16](#); *MIP Metro Group Intellectual Property GmbH & Co. KG v EUIPO*

◆**NEUSCHWANSTEIN**; Judgment of 6 September 2018 in Case [C-488/16 P](#); *Bundesverband Souvenir — Geschenke — Ehrenpreise v EUIPO*

◆**NEW ORLEANS PELICANS (fig.) / Pelikan et al.**; Judgment of 12 September 2018 in Case [T-112/17](#); *Pelikan Vertriebsgesellschaft mbH & Co. KG v EUIPO*

◆**NORMOSANG / NORMON et al.**; Judgment of 9 March 2018 in Case [T-103/17](#); *Recordati Orphan Drugs v EUIPO*

◆**NorthSeaGrid (fig.) / nationalgrid (fig.) et al.**; Judgment of 27 September 2018 in Case [T-70/17](#); *TenneT Holding BV v EUIPO*

◆**NOVUS / NOVUS (fig.) et al.**; Judgment of 19 June 2018 in Case [T-89/17](#); *Erwin Müller GmbH v EUIPO*

**NUIT PRECIEUSE (fig.) / EAU PRECIEUSE**; Judgment of 12 September 2018 in Case [T-905/16](#); *Chefaro Ireland DAC v EUIPO*

◆**nuuna (fig.) / NANU et al.**; Judgment of 18 October 2018 in Case [T-533/17](#); *Next design + produktion GmbH v EUIPO*

◆◆**NYouX (fig.) / NUXE**; Judgment of 21 February 2018 in Case [T-179/17](#); *Laboratoire Nuxe v EUIPO*

◆**ocean beach club Ibiza (fig.) / OC ocean club Ibiza (fig.) et al.**; Judgment of 1 March 2018 in Case [C-412/16 P](#) and [C-413/16 P](#) (joined cases); *Ice Mountain Ibiza, S.L. v EUIPO*

**ONCOTYPE DX GENOMIC PROSTATE SCORE**; Judgment of 23 April 2018 in Case [T-354/17](#); *Genomic Health, Inc. v EUIPO*

◆**ORIGINAL excellent dermatest (fig.)**; Judgment of 14 December 2018 in Case [T-803/17](#); *Dermatest Gesellschaft für allergologische Forschung u. Vertrieb von Körperpflegemitteln mbH v EUIPO*;

◆**ORIGINAL excellent dermatest 3-star-guarantee.de (fig.)**; Judgment of 14 December 2018 in Case [T-801/17](#); *Dermatest Gesellschaft für allergologische Forschung u. Vertrieb von Körperpflegemitteln mbH v EUIPO*

◆**ORIGINAL excellent dermatest 5-star-guarantee.de CLINICALLY TESTED (fig.)**; Judgment of 14 December 2018 in Case [T-802/17](#); *Dermatest Gesellschaft für allergologische Forschung u. Vertrieb von Körperpflegemitteln mbH v EUIPO*

◆**Outsource 2 India (fig.)**; Judgment of 31 May 2018 in Case [T-340/16](#); *Flatworld Solutions Pvt Ltd v EUIPO*





- ◆ **OV (fig.) / V (fig.)**; Judgment of 6 December 2018 in Case [T-817/16](#); *Vans, Inc. v EUIPO*
- PALLADIUM PALACE IBIZA RESORT & SPA (fig.)**; Judgment of 19 April 2018 in Case [C-75/17 P](#); *Fiesta Hotels & Resorts, S.L. v EUIPO*
- Pallas Halloumi (fig.) / HALLOUMI**; Judgment of 13 July 2018 in Case [T-825/16](#); *Republic of Cyprus v EUIPO*
- ◆ **PAP PAPOUIS HALLOUMI / HALLOUMI (I)**; Judgment of 23 November 2018 in Case [T-702/17](#); *Foundation for the Protection of the Traditional Cheese of Cyprus named Halloumi v EUIPO*
- ◆ **PAP PAPOUIS HALLOUMI / HALLOUMI (II)**; Judgment of 23 November 2018 in Case [T-703/17](#); *Republic of Cyprus v EUIPO*
- PARKWAY (BILDMARKE)**; Judgment of 6 June 2018 in Case [C-32/17 P](#); *Apcoa Parking Holdings GmbH v EUIPO*
- ◆ **PERFECT BAR**; Judgment of 8 November 2018 in Case [T-758/17](#); *Perfect Bar LLC v EUIPO*
- ◆ **PERFECT BAR (fig.)**; Judgment of 8 November 2018 in Case [T-759/17](#); *Perfect Bar LLC v EUIPO*
- Pet Cuisine (fig.) / THE PET CUISINE alimento para mascotas felices GENIAL (fig.) et al.**; Judgment of 14 December 2018 in Case [T-46/17](#); *TDH Group v EUIPO*
- ◆ **PLOMBIR**; Judgment of 13 December 2018 in Case [T-830/16](#); *Monolith Frost GmbH v EUIPO*
- POSITION OF TWO STRIPES ON A SHOE (posit.)**; Judgment of 1 March 2018 in Case [T-85/16](#); *Shoe Branding Europe BVBA v EUIPO*
- PRIMART Marek Łukasiewicz (fig.) / PRIMA et al.**; Judgment of 12 September 2018 in Case [T-584/17](#); *Przedsiębiorstwo Produkcyjno-Handlowe „Primart” Marek Łukasiewicz v EUIPO*
- PROTICURD / PROTIPLUS et al.**; Judgment of 19 April 2018 in Case [T-25/17](#); *Bernhard Rintisch v EUIPO*
- ◆ **PUMA (fig.) / PUMA (fig.) et al.**; Judgment of 26 September 2018 in Case [T-62/16](#); *Puma SE v EUIPO*
- Push and Ready (fig.)**; Judgment of 15 March 2018 in Case [T-279/17](#); *Hermann Bock GmbH v EUIPO*
- ◆ **RAPPRESENTAZIONE DI TRE STRISCE VERTICALI (fig.)**; Judgment of 6 September 2018 in Case [C-547/17 P](#); *Basic Net SpA v EUIPO*
- ◆ **RAISE**; Judgment of 3 May 2018 in Case [T-463/17](#); *Raise Conseil v EUIPO*



♦ **Raquel Superior Quality Cigarettes FILTER CIGARETTES (fig.)**; Judgment of 1 February 2018 in Case [T-105/16](#); *Philip Morris Brands Sàrl v EUIPO*

**REPOWER**; Judgment of 21 February 2018 in Case [T-727/16](#); *Repower AG v EUIPO*

♦ **ROMANTIK**; Judgment of 25 April 2018 in Case [T-213/17](#); *Romantik Hotels and Restaurants AG v EUIPO*

♦ **RSTUDIO / ER STUDIO**; Judgment of 7 March 2018 in Case [T-230/17](#); *Rstudio, Inc. v EUIPO*

♦ **Sacs pour ordinateurs portables**; Judgment of 27 February 2018 in Case [T-166/15](#); *Claus Gramberg v EUIPO*

♦♦ **Safari Club / WS Walk Safari (fig.)**; Judgment of 13 September 2018 in Case [T-418/17](#); *Eduard Meier GmbH v EUIPO*

♦ **SANTORO (fig.) / SANGRE DE TORO et al.**; Judgment of 1 February 2018 in Case [T-102/17](#); *Cantina e oleificio sociale di San Marzano v EUIPO*

**SAVORY DELICIOUS ARTISTS & EVENTS (fig.)**; Judgment of 11 July 2018 in Case [T-694/17](#); *Link Entertainment, S.L.U v EUIPO*

**SECURE DATA SPACE (fig.)**; Judgment of 15 March 2018 in Case [T-205/17](#); *SSP Europe GmbH v EUIPO*

♦ **SALMEX (fig.)**; Judgment of 6 June 2018 in Case [T-803/16](#); *Glaxo Group Ltd v EUIPO*

♦ **SALOSPIR 500 mg (fig.) / Aspirin et al.**; Judgment of 24 October 2018 in Case [T-261/17](#); *Bayer AG v EUIPO*

**SEVENFRIDAY / SEVEN et al.**; Judgment of 27 September 2018 in Case [T-448/17](#); *Sevenfriday AG v EUIPO*

**SEVENFRIDAY / SEVEN et al.**; Judgment of 27 September 2018 in Case [T-449/17](#); *Sevenfriday AG v EUIPO*

♦ **SEVENOAK (fig.) / 7seven (fig.)**; Judgment of 21 November 2018 in Case [T-339/17](#); *Shenzhen Jiayz Photo Industrial Ltd v EUIPO*

♦ **SHAPE OF A FOUR FINGER CHOCOLATE BAR (3D)**; Judgment of 25 July 2018 in Cases [C-84/17 P](#), [C-85/17 P](#) and [C-95/17 P](#) (joined cases); *Mondelez UK Holdings & Services Ltd v EUIPO — Société des produits Nestlé SA*;

**SHAPE OF HOUSING FOR MEASURING TAPE**; Judgment of 29 June 2018 in Case [T-691/17](#); *hoechstmass Balzer GmbH v EUIPO*

**SHAPE OF A KANGAROO SEEN FROM DIFFERENT VIEWS (3D)**; Judgment of 27 September 2018 in Case [T-219/17](#); *M J Quinlan & Associates Pty Ltd v EUIPO*

♦ **SHERPA**; Judgment of 29 May 2018 in Case [T-577/15](#); *Xabier Uribe-Etxebarria Jiménez v EUIPO*



- ◆ **SKYLEADER (fig.)**; Judgment of 4 May 2018 in Case [T-34/17](#); *Skyleader a.s v EUIPO*
- ◆ **SMATRIX / AsyMatrix (fig.)**; Judgment of 6 June 2018 in Case [T-264/17](#); *Uponor Innovation AB v EUIPO*
- Spray guns for paint**; Judgment of 29 November 2018 in Case [T-651/17](#); *Sata GmbH & Co. KG v EUIPO*;
- SPÜLUNGEN FÜR W.C. (WASSER- )**; Judgment of 22 November 2018 in Case [T-296/17](#); *Buck-Chemie GmbH v EUIPO*
- ◆ **STACJA BENZYNOWA (3D)**; Judgment of 16 April 2018 in Case [T-339/15 to T-343/15](#) (*joined cases*); *Polski Koncern Naftowy Orlen SA v EUIPO*
- ST ANDREWS**; Judgment of 20 November 2018 in Cases [T-790/17](#) and [T-791/17](#); *St. Andrews Links Ltd v EUIPO*
- ◆ **STAR (fig.)**; Judgment of 13 July 2018 in Case [T-797/17](#); *Star Television Productions Ltd v EUIPO*
- STAROPIlsen; STAROPLZEN / STAROPRAMEN et al.**; Judgment of 26 June 2018 in Case [T-556/17](#); *Staropilsen s. r. o. v EUIPO*
- ◆ **Steirisches Kürbiskernöl (fig.)**; Judgment of 7 June 2018 in Case [T-72/17](#); *Gabriele Schmid v EUIPO*
- STRAIGHTFORWARD BANKING**; Judgment of 22 November 2018 in Case [T-9/18](#); *Addiko Bank AG v EUIPO*
- Styriagra / VIAGRA**; Judgment of 3 May 2018 in Case [T-662/16](#); *Gall Pharma GmbH v EUIPO*
- ◆ **Support pillows**; Judgment of 13 December 2018 in Case [T-30/18](#); *Yados.r.o. v EUIPO*
- Sustainable!**; Judgment of 16 October 2018 in Case [T-644/17](#); *DNV GL AS, v EUIPO*
- SWISSGEAR**; Judgment of 23 January 2018 in Case [T-869/16](#); *Wenger SA v EUIPO*
- tèespresso / TPRESSO et al.**; Judgment of 18 May 2018 in Case [T-67/17](#); *Italytrade Srl v EUIPO*
- teaespresso / TPRESSO et al.**; Judgment of 18 May 2018 in Case [T-68/17](#); *Italytrade Srl v EUIPO*
- THE COMMODORES / Commodores et al.**; Judgment of 6 December 2018 in Case [T-459/17](#); *Fifth Avenue Entertainment LLC v EUIPO*
- THE RICH PRADA / PRADA (fig.)**; Judgment of 5 June 2018 in Case [T-111/16](#); *Prada SA v EUIPO*
- tigha / TAIGA**; Judgment of 13 September 2018 in Case [T-94/17](#); *ACTC GmbH v EUIPO*



♦ **TRIPLE TURBO (fig.) / ZITRO TURBO 2 (fig.)**; Judgment of 22 February 2018 in Case [T-210/17](#); *International Gaming Projects Ltd v EUIPO*

♦ **TSA LOCK**; Judgment of 22 March 2018 in Case [T-60/17](#); *Safe Skies LLC v EUIPO*

♦ **UROAKUT / UroCys (fig.) et al.**; Judgment of 20 September 2018 Case [T-266/17](#); *Kwizda Holding GmbH v EUIPO*

**upgrade your personality**; Judgment of 13 December 2018 in Case [T-102/18](#); *Martin Knauf v EUIPO*

♦ **V (fig.) / V (fig.) et al.**; Judgment of 6 December 2018 in Case [T-848/16](#); *Deichmann SE v EUIPO*

♦♦ **VANGUARD**; Judgment of 10 October 2018 in Case [T-93/16](#); *Rheinmetall Waffe Munition GmbH v EUIPO*

♦ **VIANEL / VIANIA et al.**; Judgment of 22 November 2018 in Case [T-724/17](#); *The Vianel Group LLC v EUIPO*

**Vienna House**; Judgment of 3 July 2018 in Case [T-402/17](#) and [T-403/17](#) (joined cases); *Vienna International Hotelmanagement AG v EUIPO*

♦ **Vieta (fig.)**; Judgment of 8 February 2018 in Case [T-879/16](#); *Sony Interactive Entertainment Europe Ltd v EUIPO*

**VIPER / VIPER et al.**; Judgment of 18 October 2018 in Case [T-109/17](#); *FCA US LLC v EUIPO*

**VITROMED Germany (fig.) / Vitromed**; Judgment of 12 December 2018 in Case [T-821/17](#); *Vitromed GmbH v EUIPO*

♦ **VSL#3**; Judgment of 18 May 2018 in Case [T-419/17](#); *Mendes SA v EUIPO*

♦ **WALLAPOP (fig.) / WALA W (fig.) et al.**; Judgment of 3 October 2018 in Case [T-186/17](#); *Unipreus, SL v EUIPO*

♦♦ **WE KNOW ABRASIVES**; Judgment of 24 April 2018 in Case [T-297/17](#); *VSM.Vereinigte Schmirgel- und Maschinen-Fabriken AG v EUIPO*

♦ **welly (fig.) / Kelly's (fig.) et al.**; Judgment of 29 November 2018 in Case [T-763/17](#); *Septona AVEE v EUIPO*

♦♦ **WILD PINK / PINK LADY et al.**; Judgment of 15 October 2018 in Case [T-164/17](#); *Apple and Pear Australia Ltd v EUIPO*

♦ **XENASA / PENTASA**; Judgment of 19 June 2018 in Case [T-362/16](#); *Tillotts Pharma AG v EUIPO*

**YAMAS (fig.) / LLAMAS**; Judgment of 20 April 2018 in Case [T-15/17](#); *Dimitrios Mitrakos v EUIPO*



♦ **ZOOM / ZOOM et al.**; Judgment of 24 April 2018 in Case [T-831/16](#); *Kabushiki Kaisha Zoom v EUIPO*

### **Preliminary Rulings**

**Bastei Lübbe**; Preliminary ruling of 18 October 2018 in Case [C-149/17](#); *Bastei Lübbe GmbH & Co. KG v Michael Strotzer*

**Coöperatieve Vereniging SNB-REACT U.A.**; Preliminary ruling of 7 August 2018 in Case [C-521/17](#); *Coöperatieve Vereniging SNB-REACT U.A. v Deepak Mehta*

**DOCERAM**; Preliminary ruling of 8 March 2018 in Case [C-395/16](#); *DOCERAM GmbH v CeramTec GmbH*

**Portugal Ramos Vinhos (adegaborba)**; Preliminary ruling of 6 December 2018 in Case [C-629/17](#); *J. Portugal Ramos Vinhos SA v Adega Cooperativa de Borba CRL*

**Junek Europ-Vertrieb GmbH**; Preliminary ruling of 17 May 2018 in Case [C-642/16](#); *Junek Europ-Vertrieb GmbH Junek Europ-Vertrieb GmbH v Lohmann & Rauscher International GmbH & Co. KG*

**Louboutin and Christian Louboutin**; Preliminary ruling of 12 June 2018 in Case [C-163/16](#); *Christian Louboutin, Christian Louboutin SAS v Van Haren Schoenen BV*

**Mitsubishi Shoji Kaisha and Mitsubishi Caterpillar Forklift Europe**; Preliminary ruling of 25 July 2018 in Case [C-129/17](#); *Mitsubishi Shoji Kaisha Ltd, Mitsubishi Caterpillar Forklift Europe BV v Duma Forklifts NV, G.S. International BVBA*

**Peek & Cloppenburg**; Preliminary ruling of 19 April 2018 in Case [C-148/17](#); *Peek & Cloppenburg KG, Hamburg v Peek & Cloppenburg KG, Düsseldorf*

**SCOTCH WHISKY**; Preliminary ruling of 7 June 2018 in Case [C-44/17](#); *Scotch Whisky Association v Michael Klotz*